

Versa Pro Central Ducted 18K-30K Installation & Owner's Manual

MODELS:

CONDENSER:

MVP-18-HP-C-230-25

MVP-24-HP-C-230-25

MVP-30-HP-C-230-25

AIR HANDLER:

MVP-18-HP-MUAH-230-25

MVP-24-HP-MUAH-230-25

MVP-30-HP-MUAH-230-25

COMPLETE SYSTEM:

MVP-18-HP-230-25

MVP-24-HP-230-25

MVP-30-HP-230-25



Read this manual carefully before installation and keep it where the operator can easily find it for future reference.

Due to updates and constantly improving performance, the information and instructions within this manual are subject to change without notice.

Version Date: 06/13/2024

Please visit www.mrcool.com/documentation to ensure you have the latest version of this manual.



CONTENTS

1	SAFETY	3
2	ACCESSORIES	6
3	INDOOR UNIT INSTALLATION	7
	3.1 Indoor Unit Parts	7
	3.2 Safety Precautions	7
	3.3 Installation Preparation & Precautions	8
	3.4 Indoor Unit Dimensions & Clearance Requirements	8
	3.5 Installation Mounting Positions	11
	3.6 Airflow Directions	11
	3.7 Wire and Piping Connections	12
	3.8 Downflow and Horizontal Right Instructions	12
	3.9 Upflow and Horizontal Left Instructions	16
4	REFRIGERANT PIPING CONNECTION	17
	4.1 Pipe Length and Elevation	17
	4.2 Connecting Quick-Connect Lineset	18
5	ELECTRIC HEAT KIT INSTALLATION	20
6	CONFIRMATION OF INDOOR UNIT	22
	6.1 Units with Electric Heating	22
	6.2 Units without Electric Heating	22
	6.3 Auxiliary Heater Electrical Data	22
	6.4 Electrical Auxiliary Heating Wiring Diagrams	23
7	OUTDOOR UNIT INSTALLATION	25
	7.1 Location Selection	25
	7.2 Drain Fitting	26
	7.3 Anchor Outdoor Unit	27
	7.4 Connecting Quick-Connect Lineset	29
8	ELECTRICAL CONNECTIONS	31
	8.1 Precautions	31
	8.2 Wiring Overview	31
	8.3 Outdoor Unit Wiring	32
	8.4 Indoor Unit Wiring	33
	8.5 Specific Wiring Methods	34
	8.6 DIP Switch Definition	36
9	SPECIFICATIONS	42
10	AIR EVACUATION	43
	10.1 Preparations and Precautions	43
	10.2 Evacuation Instructions	43
11	ADDING REFRIGERANT	44
12	TEST RUN	45
	12.1 Before Test Run	45
	12.2 Test Run Instructions	45
	12.3 24V Signal Chart	46

IMPORTANT INSTALLATION INFORMATION!**Refrigerant Line Set Connection Options, Requirements, and Stipulations**

18K/24K/30K Capacity Units - Are designed to use the MRCOOL® Quick Connect® Pre-Charged Line Set as the preferred type of refrigerant piping. If this method is used, you **DO NOT** have to retain the services of professional HVAC installer for this step. However, these capacity units can also be installed using a traditional flare nut configuration of refrigerant piping. If this method is selected, you **ARE REQUIRED** to retain the services of a professional HVAC installer and additional components to complete this form of installation will have to be purchased separately. This form of installation also **WILL REQUIRE** the refrigerant piping to be properly insulated, otherwise sweating will occur and could cause property damage. If any other form of installation is attempted, or these stipulations are not followed, the **WARRANTY WILL BE VOIDED.**

36K/48K/60K Capacity Units - Are designed to be installed using either a traditional flare nut configuration of refrigerant piping or the optional MRCOOL® No-Vac® Quick Connect® Pre-Charged Line Set. If the optional No-Vac Quick Connect Line Set is used, you **DO NOT** have to retain the services of a professional HVAC installer. If the traditional flare nut configuration is selected, you **ARE REQUIRED** to retain the services of a professional HVAC installer. Stub pipes and copper nuts are included with these capacity units to complete this type of installation. If any other form of installation is attempted, or these stipulations are not followed, the **WARRANTY WILL BE VOIDED.**

DISCLAIMER:

You are assuming risk by handling materials containing refrigerants under pressure, that if not handled properly, can cause bodily injury. If you do not feel comfortable conducting this installation process, we recommend you retain the services of a qualified HVAC professional. **Electrical work must be completed by a qualified electrical technician.******

Safety Precautions

Read Before Using

Incorrect usage may cause serious damage or injury.

The symbols below are used throughout this manual to indicate instructions that should be followed closely or actions that should be avoided to prevent death, injury, and/or property damage.



Indicates a medium level of risk which, if not avoided, may result in death or serious injury.



Indicates a low degree of risk which, if not avoided, may result in minor or moderate injury.

NOTICE

Indicates important information but not danger.



WARNING FOR PRODUCT INSTALLATION

INSTALLATION MUST BE PERFORMED BY AN AUTHORIZED DEALER OR SPECIALIST. DEFECTIVE INSTALLATION CAN CAUSE WATER LEAKAGE, ELECTRICAL SHOCK, OR FIRE.

******ELECTRICAL WORK MUST BE COMPLETED BY A QUALIFIED ELECTRICAL TECHNICIAN******

⊘ DO NOT install the unit in a location that may be exposed to combustible gas leaks. If combustible gas accumulates around the unit, it could cause fire.

⊘ DO NOT turn on the power until the installation and all work has been completed.

⊘ DO NOT install a unit equipped with an auxiliary electric heater within 3 ft (1 m) of any combustible materials.

1. Installation must be performed according to the installation instructions. Improper installation could cause water leakage, electrical shock, fire, and could void the warranty. (In North America, all wiring/electrical work must be performed in accordance with the requirements of NEC and CEC by authorized personnel only.)
2. Contact an authorized service technician for repair or maintenance of this unit. This appliance must be installed in accordance with national wiring regulations.
3. Only use the included accessories, parts, and specified parts for installation. Using non-standard parts can cause water leakage, electrical shock, fire, and/or failure of the unit.
4. Install the unit in a firm location that can support the unit's weight. If the location cannot support the unit's weight, or the installation is not done properly, the unit may drop and cause serious injury and damage.
5. Install the drainage piping according to the instructions in this manual. Improper drainage could cause water damage to your home and/or property.
6. When moving or relocating the air conditioner, consult experienced service technicians for disconnection and re-installation of the unit.
7. For detailed information of how to install the indoor and outdoor units to their respective supports, please refer to the indoor unit installation and outdoor unit installation sections of this manual.
8. Excessive Weight Hazard: Use two or more people when moving and installing the unit. Failure to do this could result in personal injury.



WARNING FOR PRODUCT USE

- ⓘ ***DO NOT*** insert fingers, rods, or other objects into the air inlet or outlet. This could cause injury, since the fan may be rotating at high speeds.
 - ⓘ ***DO NOT*** use flammable sprays such as hair spray, lacquer or paint near the unit, as this could cause fire and/or an explosion.
 - ⓘ ***DO NOT*** operate the unit in places near or around combustible gases. Emitted gas may collect around the unit and cause an explosion.
 - ⓘ ***DO NOT*** allow children to play with the appliance. Children must be supervised around the unit at all times.
 - ⓘ ***DO NOT*** operate the unit in a room where it could be exposed to excessive amounts of water, such as a bathroom or laundry room. Exposure to excessive water amounts can cause the electrical components to short circuit.
 - ⓘ ***DO NOT*** expose your body directly to direct cool airflow from the unit for a prolonged period of time.
1. If the unit operates abnormally (emits strange noises or a burning smell), immediately turn off the unit and disconnect the power in order to avoid electric shock, fire, and/or injury. Call your local dealer, or MRCOOL® tech support at (270) 366-0457, for further assistance.
 2. If the air conditioner is used together with burners or other heating devices, thoroughly ventilate the room in order to avoid an oxygen deficiency.
 3. In certain functional environments (such as kitchens and server rooms etc.), the use of specially designed air-conditioning units is highly recommended.
 4. This appliance can be used by children (8 years and older) and persons with reduced physical, sensory or mental capabilities, or lack of experience and knowledge if they have been given instruction concerning the use of the appliance and understand the hazards involved.
 5. Improper installation, adjustment, alteration, service, or maintenance can cause property damage, personal injury or loss of life. Installation and service must be performed by a licensed professional HVAC installer, service agency, or the gas supplier.



ELECTRICAL WARNINGS

******ELECTRICAL WORK MUST BE COMPLETED BY A QUALIFIED ELECTRICAL TECHNICIAN******

- ⓘ ***DO NOT*** share the power supply with other appliances. An improper or insufficient power supply could cause fire and/or electrical shock.
1. The product must be properly grounded during installation or electrical shock could occur.
 2. Appropriate wiring standards, regulations, and the installation manual must be followed for all electrical work.
 3. If connecting power to fixed wiring, an all-pole disconnection device must be incorporated in the fixed wiring in accordance with the wiring rules and must meet the following requirements: at least 3 mm of clearances in all poles, a leakage current that may exceed 10 mA, and a residual current device (RCD) having a rated residual operating current not exceeding 30 mA.
 4. For all electrical work, fuse the specified cables. Connect cables tightly and clamp them securely to prevent external forces from damaging the terminal. Improper electrical connections could overheat, causing fire and/or electrical shock.
 5. All electrical connections must be made according to the Electrical Connection Diagram located on the panels of the indoor and outdoor units.
 6. All wiring must be properly arranged to ensure that the control board cover can close properly. If the control board cover is not properly closed, it can lead to corrosion and cause the connection points on the terminal to heat up, catch fire, or cause electrical shock.



WARNING FOR CLEANING & MAINTENANCE

- ⊘ **DO NOT** clean the unit with excessive amounts of water.
- ⊘ **DO NOT** clean unit with combustible cleaning agents, as these could cause deformation and/or fire.

1. Turn off the device and disconnect the power before cleaning. Failure to do this could result in electrical shock.

TAKE NOTE OF FUSE SPECIFICATIONS

- The unit's circuit board (PCB) is designed with a fuse to provide over-current protection. This fuse must be replaced with an identical component if the existing fuse is blown.
- The specifications of the fuse are printed on the circuit board, examples of such are T5A/250VAC and T10A/250VAC.

! CAUTION

- ⊘ **DO NOT** allow the air conditioner to operate for extended periods of time with the doors or windows open, or in very high humidity.
- ⊘ **DO NOT** operate the air conditioner with wet hands, as this could cause electric shock.
- ⊘ **DO NOT** use device for any other purpose than its intended use.
- ⊘ **DO NOT** climb onto or place objects on top of the outdoor unit.

1. Make sure that water condensation can drain smoothly and unhindered from the unit.
2. Turn off the unit and disconnect the power if the unit will not be used for an extended period of time.
3. As with any mechanical equipment, contact with sharp metal edges can result in personal injury. Ensure care is taken when handling the unit and any of its accessories by wearing gloves and protective clothing.

NOTE ON FLUORINATED GASES (NOT APPLICABLE FOR R-290 UNITS):

1. This unit contains fluorinated greenhouse gases.
2. For specific information on the type of gas and the amount, please refer to the relevant label on the unit itself.
3. Service, maintenance, and repair of this unit must be performed by a certified technician.
4. Product un-installation and recycling must be performed by a certified technician.
5. When checking the unit for leaks, maintain proper record-keeping of all checks.

NOTE ON STATIC PRESSURE:

The allowed static pressure range of the air conditioner on site 0.00-0.80 in H₂O (0-200 Pa). The data below represents the static pressures at the full required airflow used for AHRI testing.









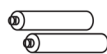
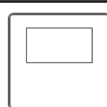

Model	18-24K	30-36K	48-60K
Pressure	0.5 in H ₂ O (125 Pa)	0.5 in H ₂ O (125 Pa)	0.5 in H ₂ O (125 Pa)

Units: Inch of Water Column (Pascals)

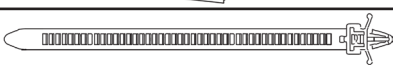
NOTE: The maximum functional total external static pressure cannot exceed 0.80 in WC (200 Pa). The airflow reduces significantly with pressures above and beyond 0.80 in WC (200 Pa). The system design should allow for the increased resistance of filters as they become dirty.

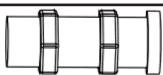

2-Accessories

The listing below shows the accessories and parts (these may vary depending on purchase & options). Use all of the installation parts and accessories to install the system. Improper installation may result in water leakage, electrical shock, fire, and/or equipment failure.

PART	LOOKS LIKE	QUANTITY
Owner's & Installation Manual		1
Remote Control		1
Remote Control Manual		1
Batteries		2
Wired Thermostat		1
Thermostat Manual		1
Cable Ties		2
Foam Insulator		4
Quick Connecting Pipe		2
Insulation Pipe		1
DIYPRO™ Cable		1
Quick Connect® Line Set		1

NOTE:
The wired system control functions as an IR receiver for the handheld remote. If the remote is not used, it must be retained with the indoor unit to adjust parameters, and for troubleshooting.

Included Optional Accessories:

PART	LOOKS LIKE	QUANTITY
Drain Fitting (In Outdoor Packaging)		1
Seal (In Outdoor Packaging)		1
Flare Nut (In Indoor Packaging)		1

3 INDOOR UNIT INSTALLATION

3.1 Indoor Unit Parts

Coil compartment
(Access panel Removed)

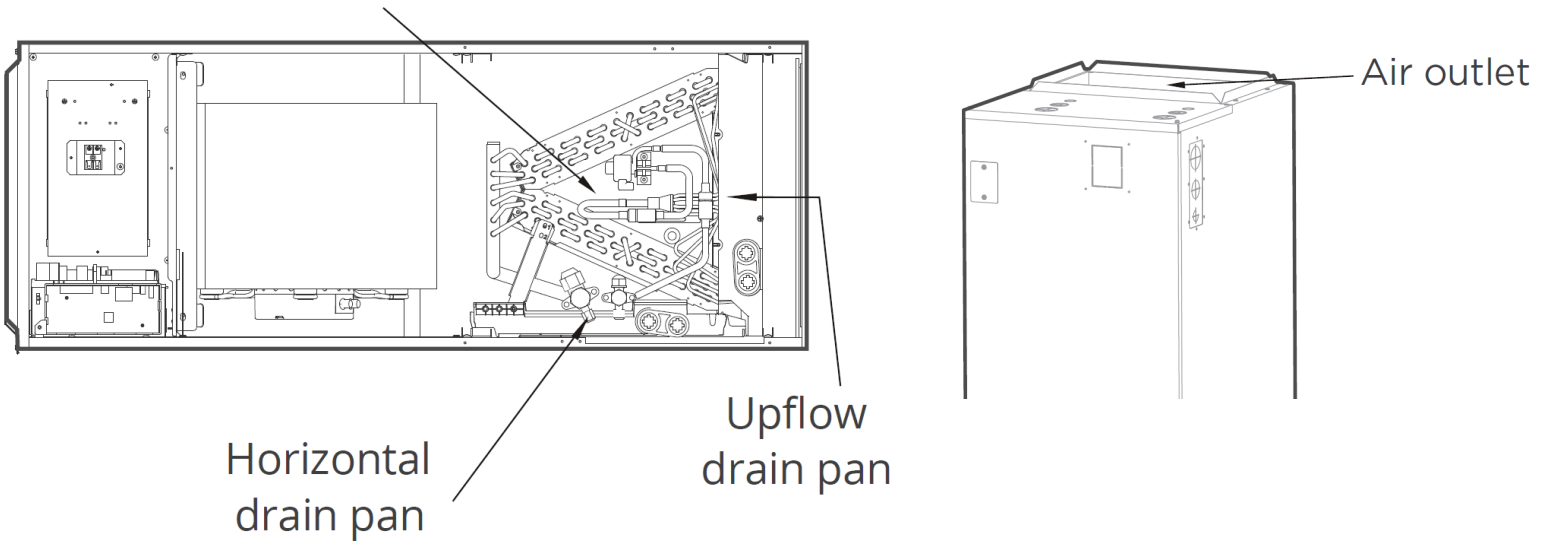

3.2 Installation Safety Precautions

! CAUTION

- Install the indoor and outdoor units, cables, and wires at least 3.2 ft (1 m) away from televisions or radios to prevent static or image distortion. Depending on the appliances, a 3.2ft (1m) distance may not be sufficient.
- The indoor unit must be electrically grounded per national and local electrical codes.

! WARNING

⚠ DO NOT install the indoor unit in any of the following locations:

- Areas where oil drilling or fracking is being performed.
- Coastal areas with high salt content in the air. Areas with caustic gases in the air, such as near laundry vents.
- Areas with strong electromagnetic waves.
- Areas where flammable materials or gas are stored.
- Rooms with high humidity, such as bathrooms or laundry rooms.
- Areas where the air inlet and outlet may be obstructed.

! WARNING

- Be sure to apply sealant around any places where wires, refrigerant piping, and condensate piping enter the air handler cabinet.
- Use duct tape and/or Permagum to seal any space around the holes where condensate piping exits the cabinet. Warm air must not be allowed to enter through any gaps or holes in the cabinet.
- Remove all accessories and packing from the air outlet before installation.

! WARNING

- There must be an airtight seal between the bottom of the air handler and the return air plenum. In order to achieve this, use fiberglass sealing strips, foil duct tape, caulking, or an equivalent sealing method to ensure a tight seal.
- Return air must not be drawn from a room where the air handler or any gas-fueled appliance (ex: water heater), or carbon monoxide-producing device (ex: wood fireplace) is installed.

3.3 Installation Preparation & Precautions

The indoor unit should be installed in a location that meets the following requirements:

- ✓ Enough room for the installation and maintenance to be performed.
- ✓ Enough room for the refrigerant piping and drain pipe.
- ✓ On a structure that can support its weight. If the structure is too weak, the unit may fall and cause personal injury, unit and property damage, or death.
- ✓ At least 18 inches (46 cm) above the floor for a garage installation. Failure to follow these instructions can result in death, explosion, or fire.
- ✓ If suspended, the structure must support the weight of the unit.
- ✓ The ceiling is horizontal and its structure can sustain the weight of the indoor unit.
- ✓ The air inlet and outlet are not impeded.
- ✓ Room for properly sized return and supply ducts must be maintained.
- ✓ There is no direct radiation from heaters.

3.4 Dimensions & Clearance Requirements

Indoor Unit Clearance Requirements

The distance between the mounted indoor unit should meet the specifications illustrated in the following diagrams.

Horizontal Installations

Plenum Clearances

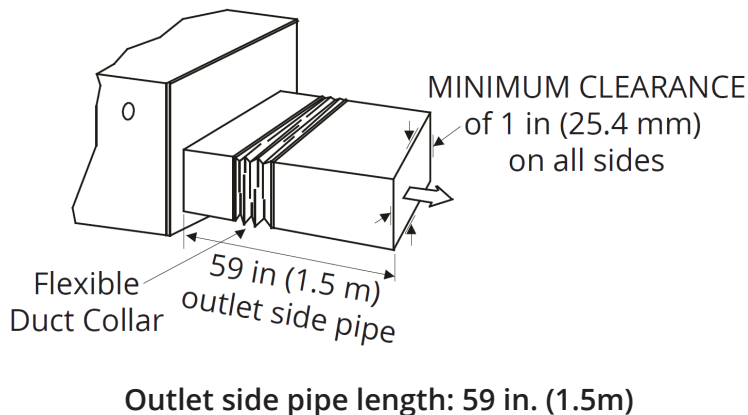

Vertical Installations



Mounting instructions: When installed vertically (upflow or downflow), the lower end of the air outlet needs to be connected to the L-shaped metal air duct and fastened by screws.

3 INDOOR UNIT INSTALLATION

Dimensions

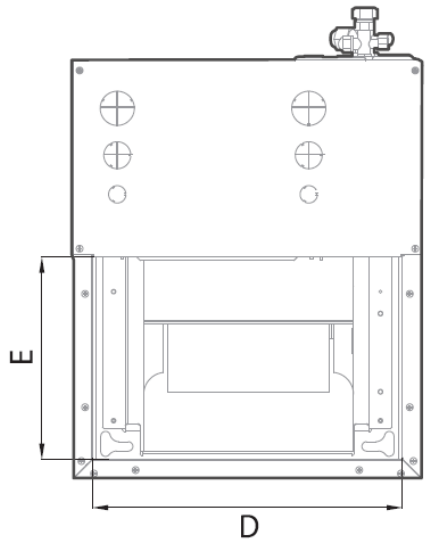
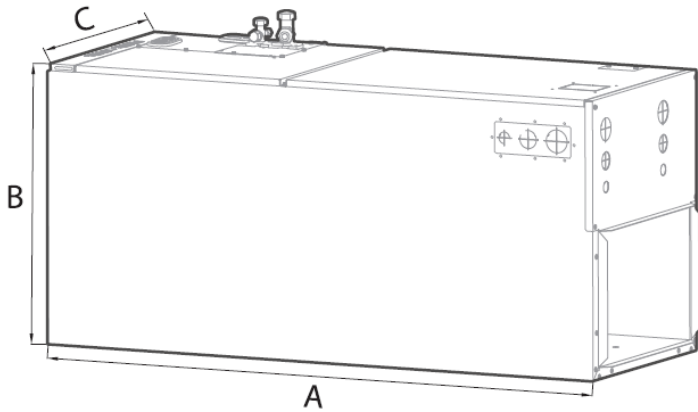

Dimensions	Model Capacity (BTU/H)		
	18K-24K	30K-48K	60K
Length of A	45 in (1143 mm)	49 in (1245 mm)	53 in (1346 mm)
Length of B	21 in (533 mm)	21 in (533 mm)	21 in (533 mm)
Length of C	17.5 in (445 mm)	21 in (533 mm)	24.5 in (622 mm)
Length of D	15.75 in (400 mm)	19.3 in (490 mm)	22.8 in (580 mm)
Length of E	10.25 in (260 mm)	10.25 in (260 mm)	10.25 in (260 mm)

Filter Dimensions

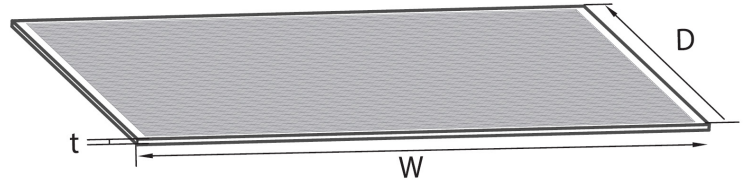

Filter must meet the requirements of UL900.

Model Capacity (BTU/H)	Width (W)	Depth (D)	Thickness (t)
18K-24K	16 in (406.4 mm)	20 in (508 mm)	.96 in (25.4 mm)
30K-48K	19.5 in (495.3 mm)	20 in (508 mm)	.96 in (25.4 mm)
60K	23 in (584.2 mm)	20 in (508 mm)	.96 in (25.4 mm)

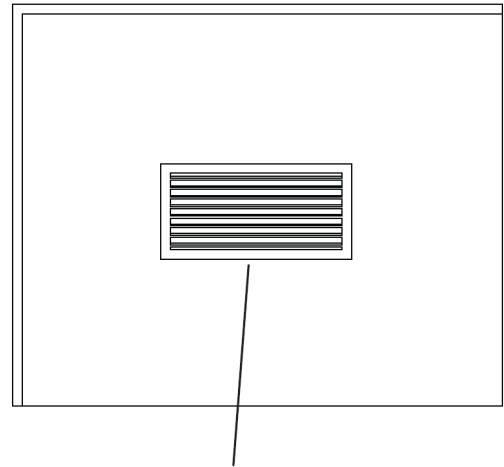

Air outlet grille

! CAUTION

Air outlet grille should be installed at the air outlet with the dimension between grille sheets less than 1 inch (25.4mm). The air outlet grille cannot be removed without tools.

Installation Position Requirements

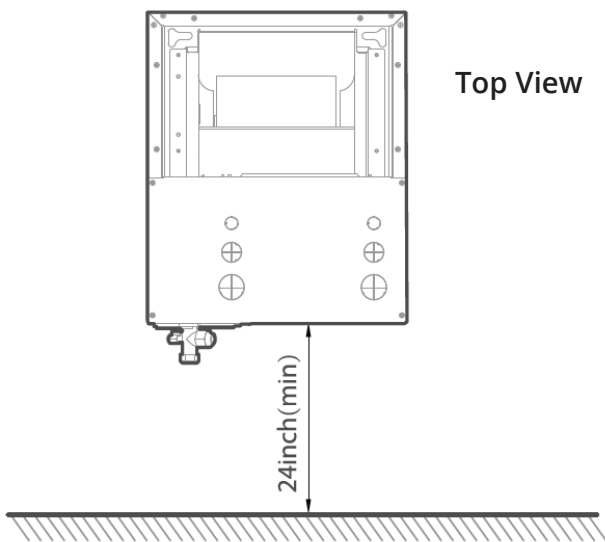

Vertical installations

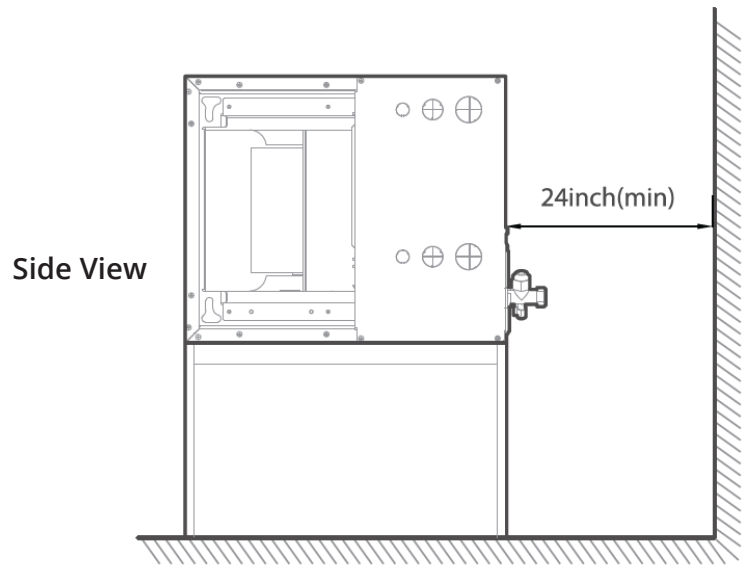

Horizontal installations

Note on Ductwork & Connections

- Air supply and return can be handled in one of several ways depending on which is best suited for the type of installation. Please see the dimensions on the previous page to determine duct inlet and outlet connection sizes to match the air handler. The vast majority of problems encountered with combination cooling systems can be linked to improperly designed or installed ductwork. For this reason, it is highly important that the duct system be properly designed and installed.
- The use of flexible duct collars will minimize the transmission of vibration and noise into the conditioned space. In an installation where the return air duct is short, or where sound is likely to be a problem, a sound absorbing liner should be used inside the duct.
- Insulation of the ductwork is a requirement anywhere it runs through an uncooled space during the cooling season.
- The use of a vapor barrier is recommended to prevent absorption of moisture from the surrounding air into the insulation.
- The supply air duct should utilize a properly sized transition in order to match the unit opening.
- All ducts should be suspended using flexible hangers and never fastened directly to the structure. This unit is not designed for non-ducted (free-blow) applications.
- Ductwork should be fabricated and installed in accordance with local and/or national codes.

! CAUTION

- A field-fabricated secondary drain pan (not included), with a drain pipe to the outside of the building is required in all installations over a finished living space or in any area that may be damaged by overflow from the main drain pan. **NOTE: A secondary drain pan is required for horizontal installations.**
- This unit is not designed for non-ducted (free-blow) applications. Electric heat kit elements and/or blower is easily accessible without ductwork and creates a safety hazard that could result in electric shock and/or personal injury.

3 INDOOR UNIT INSTALLATION

3.5 Installation Mounting Positions

The unit can be installed in a Vertical (downflow or upflow) or a Horizontal (right or left) configuration.

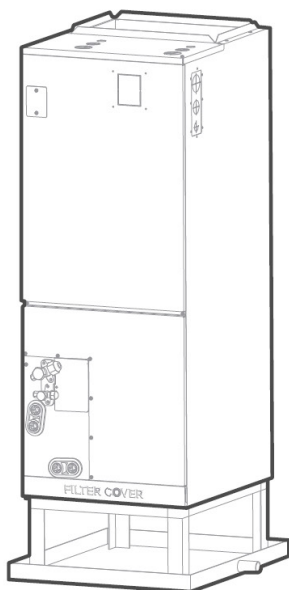

Vertical up

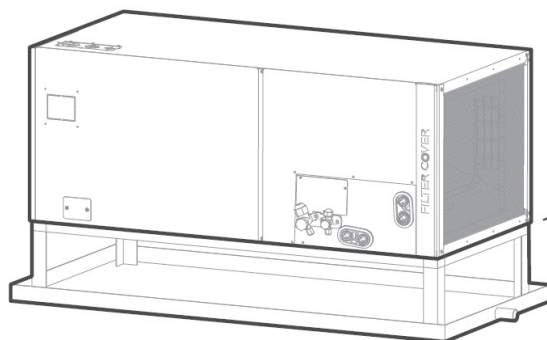

At least
5in(12.7cm)

Horizontal

Notice

- Vertical Up and Horizontal Left installation does not need to change the direction of the evaporator.

3.6 Airflow Directions

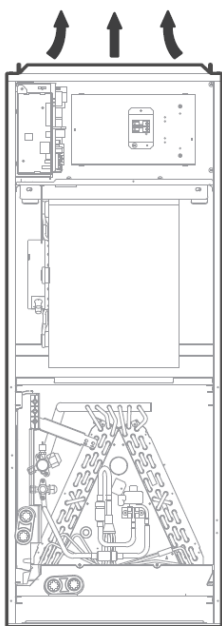

Upflow

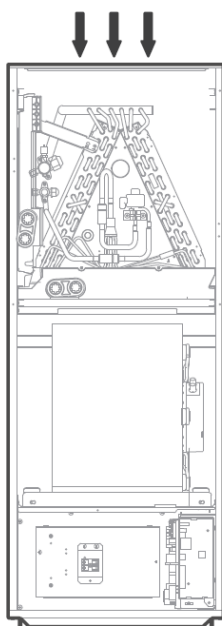

Downflow

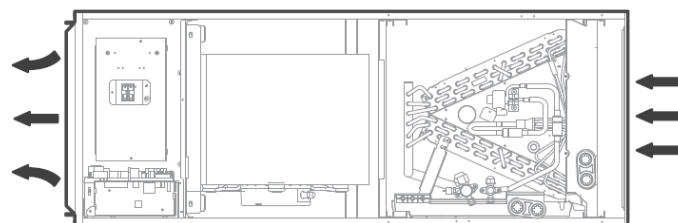

Horizontal left

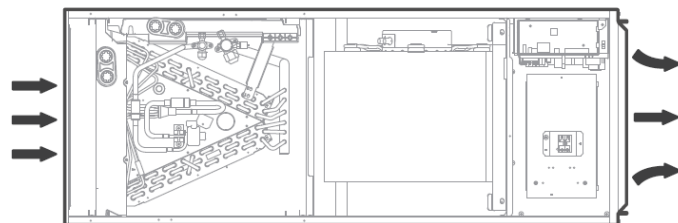

Horizontal right

3 INDOOR UNIT INSTALLATION

3.7 Wire & Piping Connections

Follow these steps to perform a vertical down and horizontal right installation:

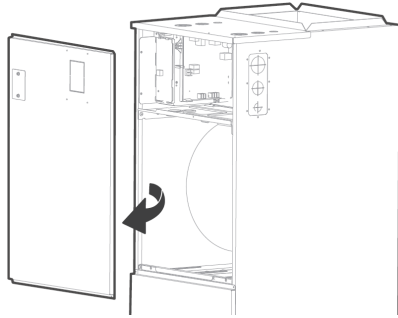

- Step 1:**
Open the upper cover.
- Step 2:**
Open the cover of the electronic control box.
- Step 3:**
Connect the wire according to the wiring diagram.
- Step 4:**
Connect the pipes and install drainage pipes.

3.8 Installation for Horizontal Right or Downflow Configurations

The steps below detail the installation of a horizontal left or vertical upflow indoor unit once it has been securely mounted in place.

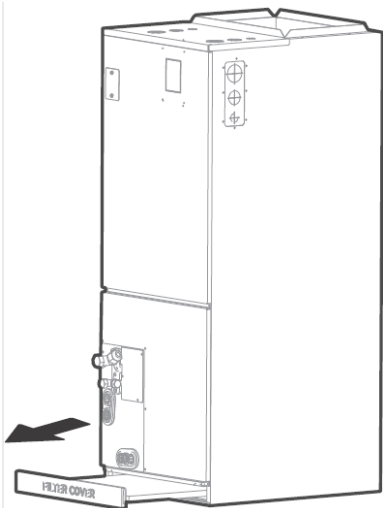

1. Remove the filter door, then remove the filter.

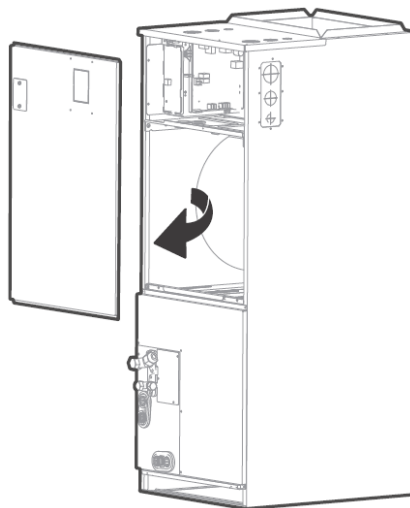

2. Remove the upper cover assembly.

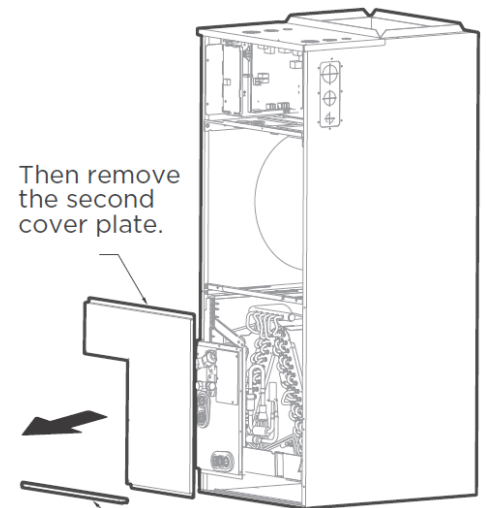

Then remove the second cover plate.

Remove the bottom cover first.

3. Remove evaporator cover plate.

4. Identify the position of the evaporator's temperature sensor.

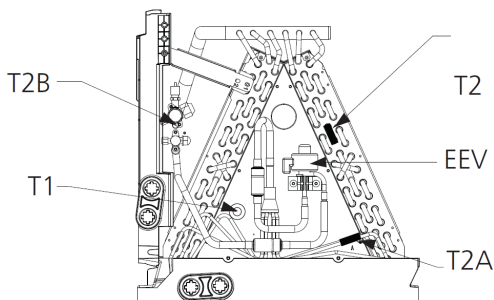

18-24K Model

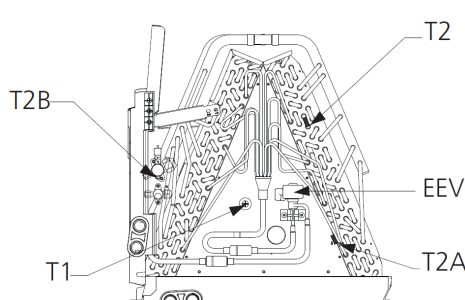

30-48K Model

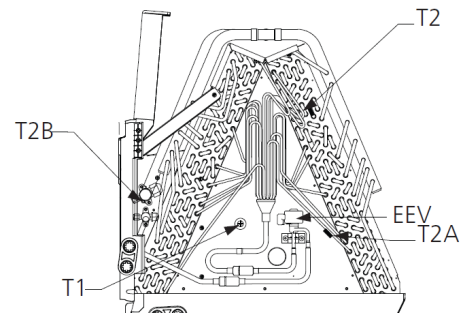

60K Model

3 INDOOR UNIT INSTALLATION

5. Unplug temperature sensors T1 and T2 from the control board.

- T1: Room Temperature Sensor
- T2: Evaporator Central Sensor Plug
- T2A: Evaporator Input Sensor Plug
- T2B: Evaporator Output Sensor Plug

6. Remove T1 and T2 Sensor wire ties.

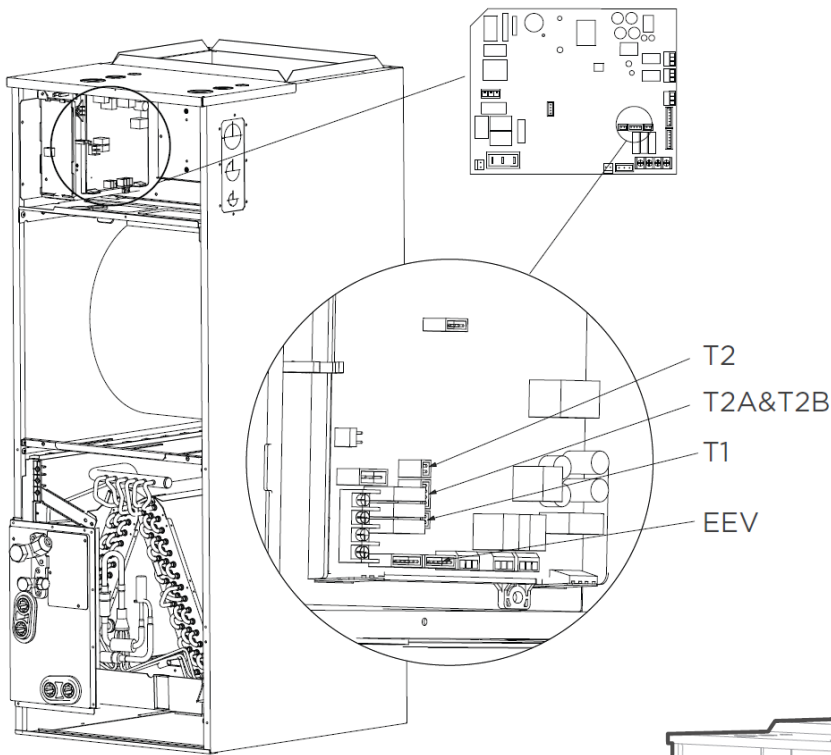

7. Take out the evaporator and drain pan and rotate 180° (when a vertical down configuration is needed).

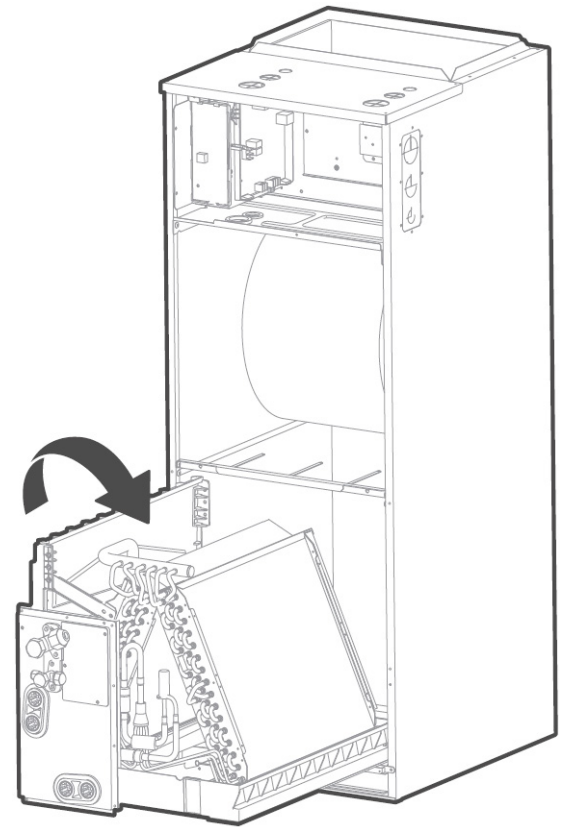

8. Adjust the mounting parts positioning according to the direction of the unit.

NOTE
This unit model does not have T2A, T2B, or EEV

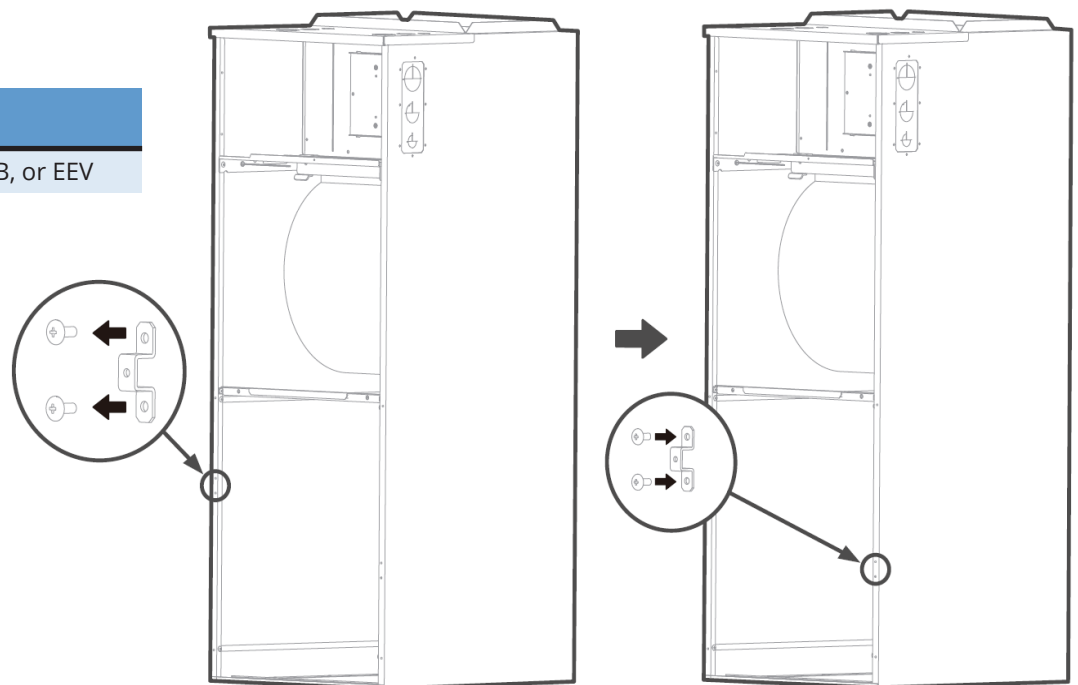

3 INDOOR UNIT INSTALLATION

9. Reinstall the evaporator and drain pan.

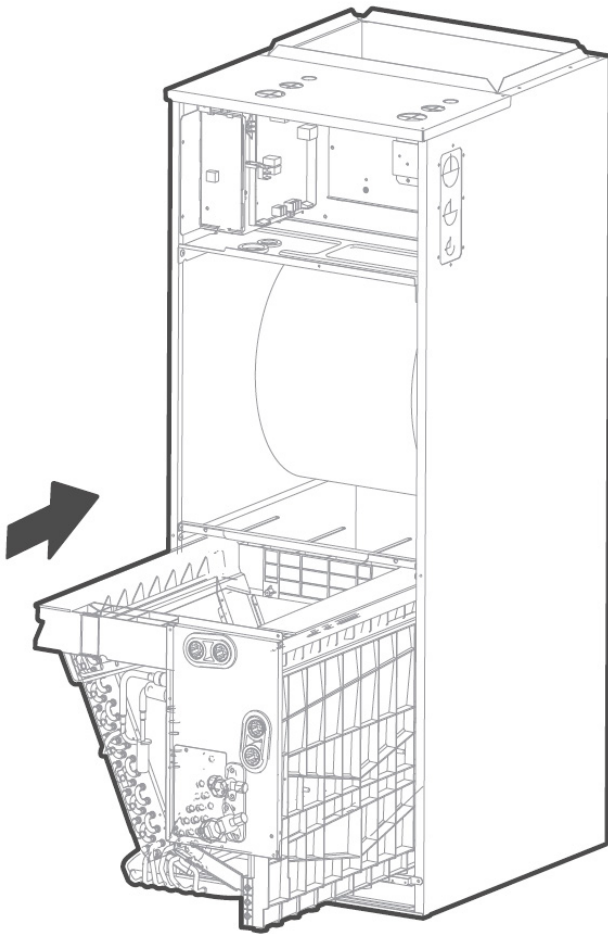

10. Reinstall T1, T2, T2A, and T2B sensor plugs and electronic expansion valve (EEV) and tie up the sensor wires. The evaporator is now assembled in place.

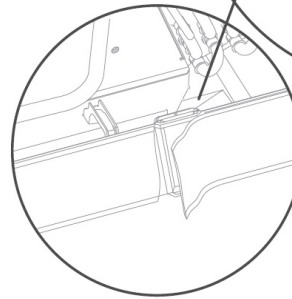
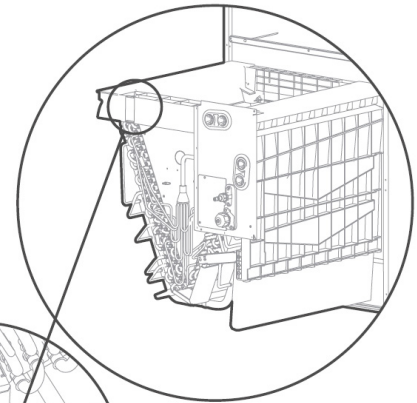

Cut the foam gasket.

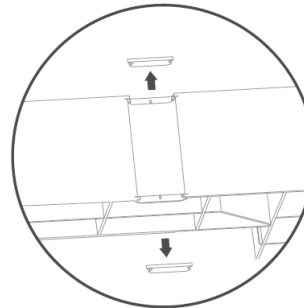

Remove knockouts as shown in the figure.

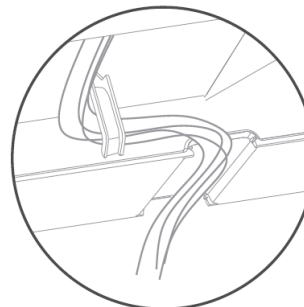

Hook the wire into the buckle and go down from the wire slot.

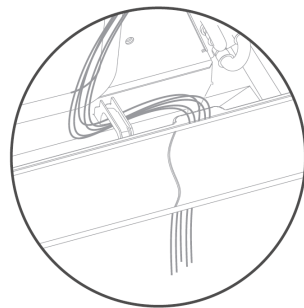

Replace foam gasket over wires.

NOTE

The wire body needs to pass through the wire groove from the drain pan and attach to the hook on the drain pan.

3 INDOOR UNIT INSTALLATION

11. Use cable ties to attach the room temperature sensor as shown in the figure.

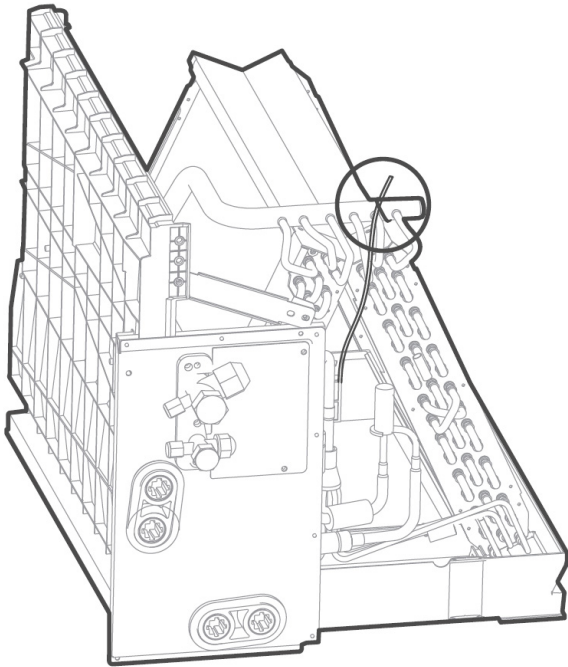

12. Reinstall evaporator cover plate.

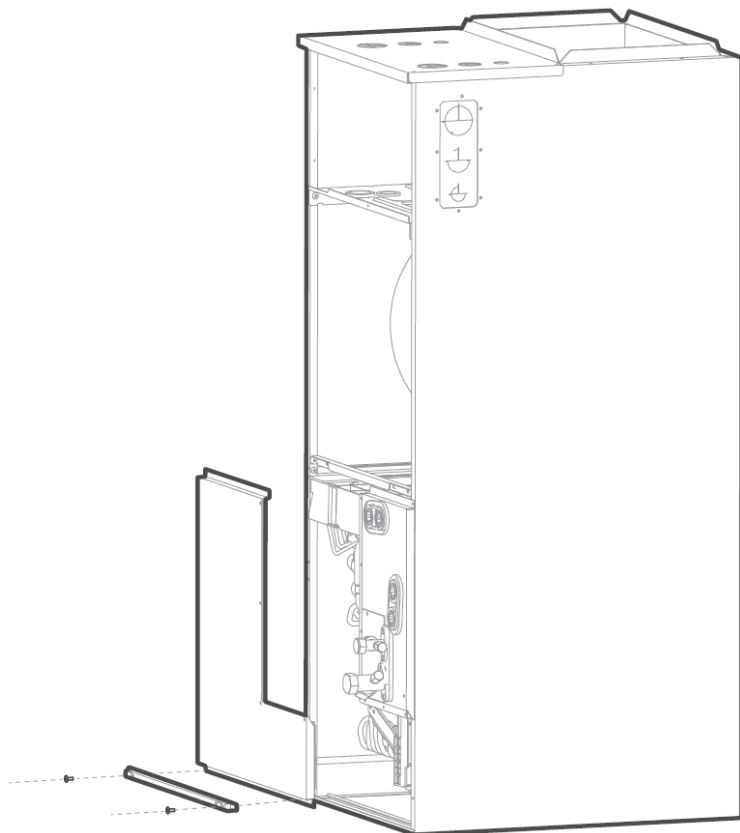

13. Connect the wire according to the wiring diagram.

14. Reassemble the upper cover and reinstall the filter and filter cover plate.

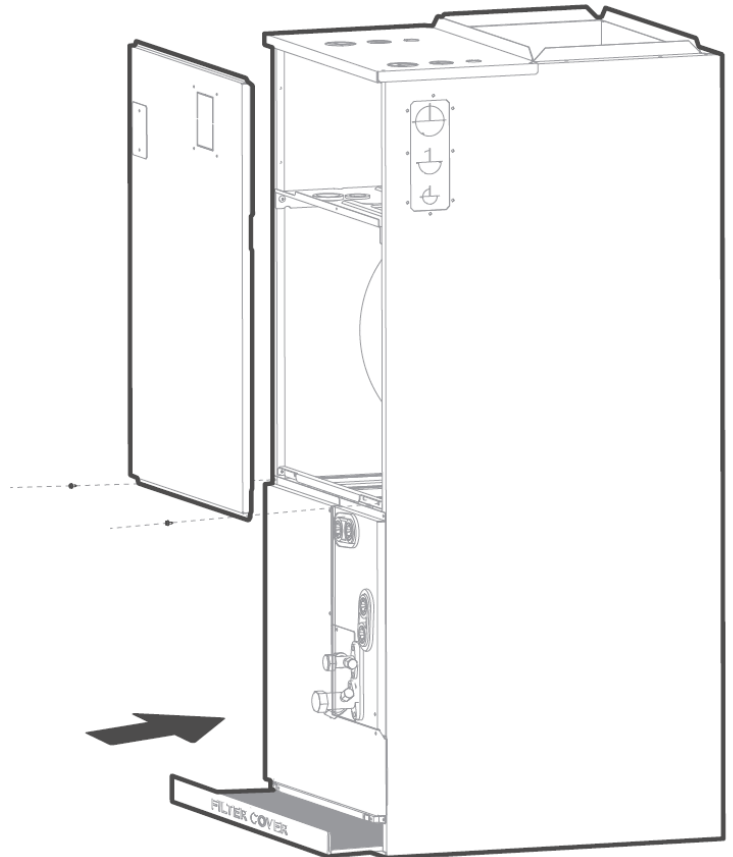

15. Connect the pipes and install drainage pipes.

! CAUTION FOR PIPE INSTALLATION

- Insulate all piping to prevent condensation, which could lead to water damage.
- The drainpipe is used to drain water away from the unit. If the drainpipe is bent or installed incorrectly, water may leak and cause a water-level switch malfunction.
- In HEAT mode, the outdoor unit will discharge water. Ensure that the drain hose is placed in an appropriate area to avoid water damage and icy conditions on walkways.
- **DO NOT** pull the drainpipe forcefully. This could disconnect it.

NOTICE

If installed above a finished living space, a secondary drain pan (as required by many building codes) must be installed under the entire unit and its condensate drain line must be routed where the excess drainage is not in view.

NOTICE ON PIPE PURCHASING

Installation requires PVC pipe or other suitable material per local and national codes. These can be found at your local hardware store or dealer.

! WARNING

- After removing the drain pan plug(s), check the drain hole(s) to verify that the drain opening is fully clear and free of any debris. Also check to ensure no debris has fallen into the drain pan during installation that could plug the drain opening. Apply sealant around the exiting drain pipe and the liquid and suction lines to prevent the infiltration of humid air.
- On units of this type in which the blower “draws” in air rather than “blows” air through the coil, traps must be installed in the condensate drain lines (primary and auxiliary, if used). Traps prevent the blower from drawing air through the drain lines into the air supply.

3.9 Upflow & Horizontal Left Configurations

The unit operates with a negative pressure at the drain connections and a drain trap is required. The trap must be installed as close to the unit as possible. Make sure the top of the trap is below the connection to the drain pan to allow complete drainage of the pan.

Vertical Discharge

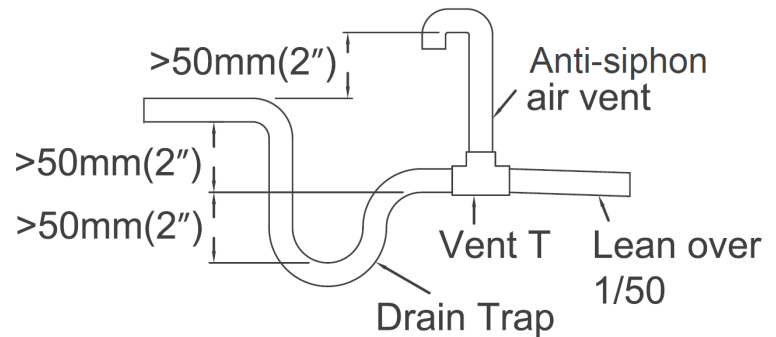
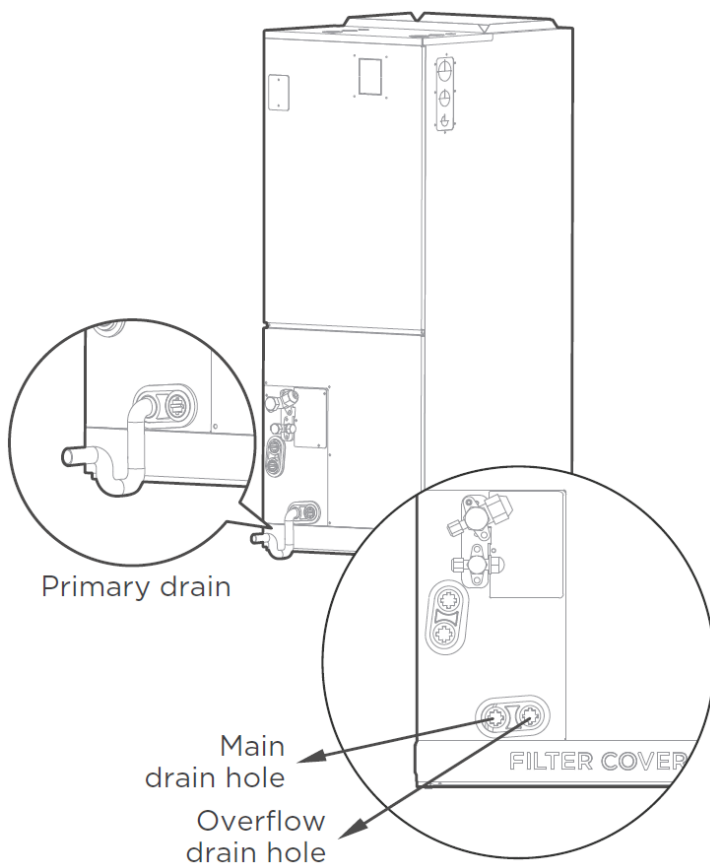

NOTICE

Horizontal runs must also have an anti-siphon air vent (standpipe) installed ahead of the horizontal run to eliminate air trapping.

NOTE ON DRAINPIPE INSTALLATION:

- The figure shows how to trap or plug all drains during vertical discharge.
- The figure shows how to trap or plug all drains during right-hand discharge.
- The seal plug is supplied and should be screwed tightly by hand only.
- Incorrect installation could cause water to flow back into the unit and flood.

! CAUTION

- The drainpipe outlet should be at least 1.9 in (5 cm) above the ground.
- If it touches the ground, the unit may become blocked and malfunction.

4 REFRIGERANT PIPING CONNECTION



WARNING ON REFRIGERANT PIPING

All field piping must be completed by a licensed technician and must comply with all local and national regulations.

- When the air conditioner is installed in a small room, precautions must be taken to prevent the refrigerant concentration in the room from exceeding the safety limit.
- When installing the refrigeration system, ensure that air, dust, moisture, or foreign substances do not enter the refrigerant circuit. Contamination in the system may cause poor operating capacity, high pressure in the refrigeration cycle, explosion, or injury.
- Ventilate the area immediately if there is refrigerant leakage during the installation. Leaked refrigerant gas is both toxic and may be flammable. Ensure there is no refrigerant leakage after completing the installation work.

4.1 Pipe Length & Elevation

Maximum length and drop height

Model Capacity (BTU/H)	Maximum Length of Piping	Maximum Drop Height
18K	98.4 ft (30 m)	65.6 ft (20 m)
24K/30K	164 ft (50 m)	82 ft (25 m)
36K/48K/60K	213 ft (65 m)	98.4 ft (30 m)

Ensure that the length of the refrigerant pipe, the number of bends, and the drop height between the indoor and outdoor units meet the requirements shown in the table:

Name	Shape	Quantity
Connecting Pipe Assembly	Liquid Side	Φ6.35 (1/4in)
		Φ9.52 (3/8in)
		Φ12.7 (1/2in)
	Gas Side	Φ16 (5/8in)
		Φ19 (3/4in)
		Φ22 (7/8in)
Parts must be purchased separately. Consult your dealer or technician about the proper pipe size for the unit you purchased.		

NOTICE

If using a MRCOOL® DIY® condenser, the max line set length is 75 ft (23m) with a max of one (1) coupler kit.



CAUTION-OIL TRAPS

- If oil flows back into the outdoor unit's compressor, this may cause liquid compression or deterioration of the oil return. Oil traps in the rising gas pipe can prevent this.
- For units less than 36,000Btu/h, an oil trap should be installed every 6m (19.7ft) of vertical suction line riser.
- For units greater than 36,000Btu/h, an oil trap should be installed every 10m(32.8ft) of vertical suction line riser.

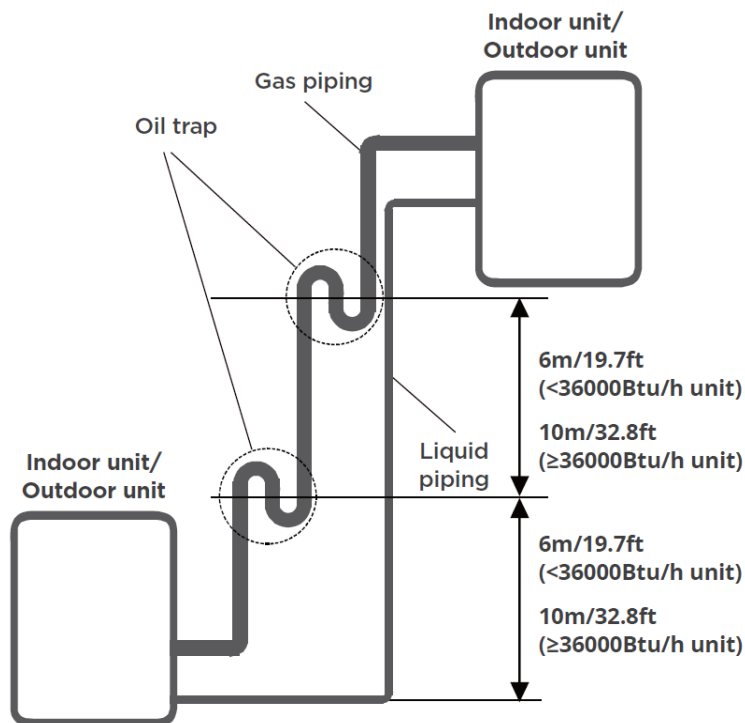

4 REFRIGERANT PIPING CONNECTION

4.2 Connecting Quick-Connect Refrigerant Lines

IMPORTANT INFORMATION

- Closely follow the detailed instructions for connecting the refrigerant lines to the indoor and outdoor units. Failure to install in accordance with these installation instructions may void the warranty.
- Do not remove the sealing caps and stoppers until immediately before you install the lines.
- To prevent leaks, ensure that the quick-connector threading and valve body is free of dirt and contaminants prior to assembly. Moisture and/or foreign material may impact function, possibly leading to refrigerant loss and/or premature failure.
- Only install refrigerant lines outdoors during dry weather.
- The refrigerant lines must not be installed and then plastered over.
- Care should be taken to prevent release of refrigerant to the environment while installing or servicing the equipment. Always wear proper personal protective equipment when handling refrigerant. (e.g. – work gloves; safety glasses; etc.)
- Do not smoke during installation.
- The equipment must never be operated without fully completing the refrigerant line connection.
- Failure to do so will damage the equipment.
- Follow the required tightening torques defined in the table based on connector size. Under-tightening may result in a refrigerant leak, while over-tightening could damage components.
- For any questions about the installation or connection of the refrigerant lines, contact your customer service team or a licensed HVAC contractor.
- The quick-connect installation method is only used for the models that have been pre-charged with refrigerant and equipped with quick-connect valves.

Step 1:

When immediately ready to install the refrigerant line, remove the plastic seals/caps from the indoor unit and refrigerant line.

Align the Quick Connector with the valve of the indoor unit, ensuring that they are the same size.

Tighten them with two wrenches (one on the valve and the other rotating the Quick Connector) according to the torque table.

Screw the Quick Connecting line onto the quick connector and hand tighten . Being careful not to cross-thread.

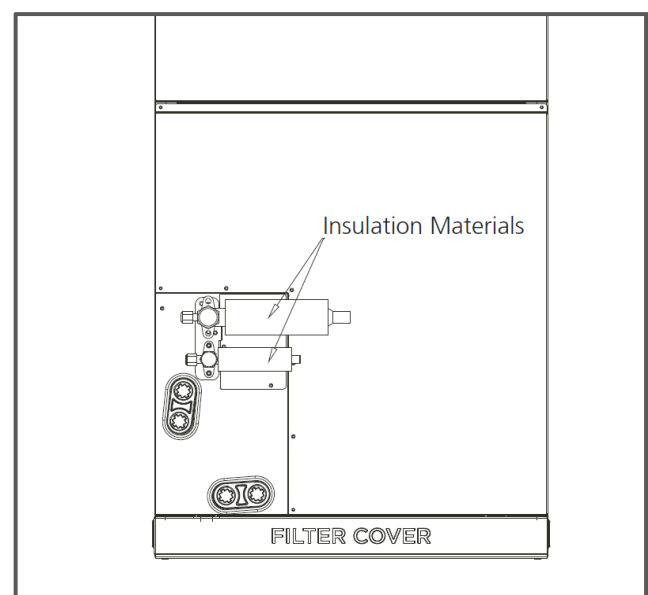
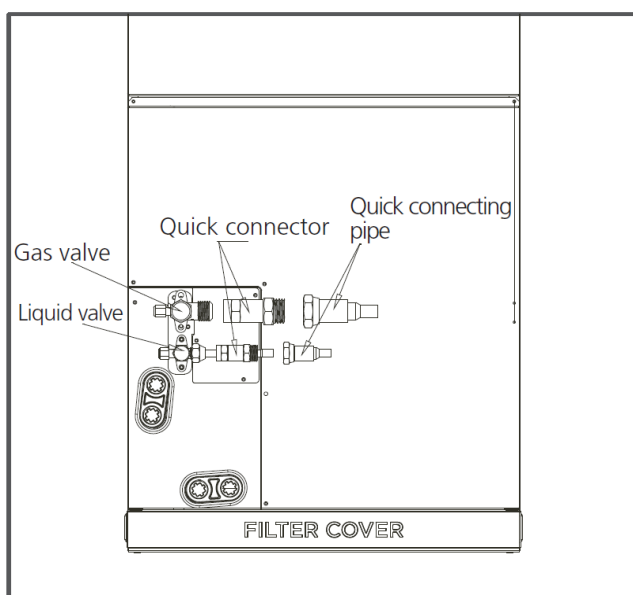

4 REFRIGERANT PIPING CONNECTION

Step 2:

Using two open-ended wrenches, tighten the quick-connect nut (2) on the line according to the torque specification in the table below, being careful not to loosen the connection (1) to the valve body.

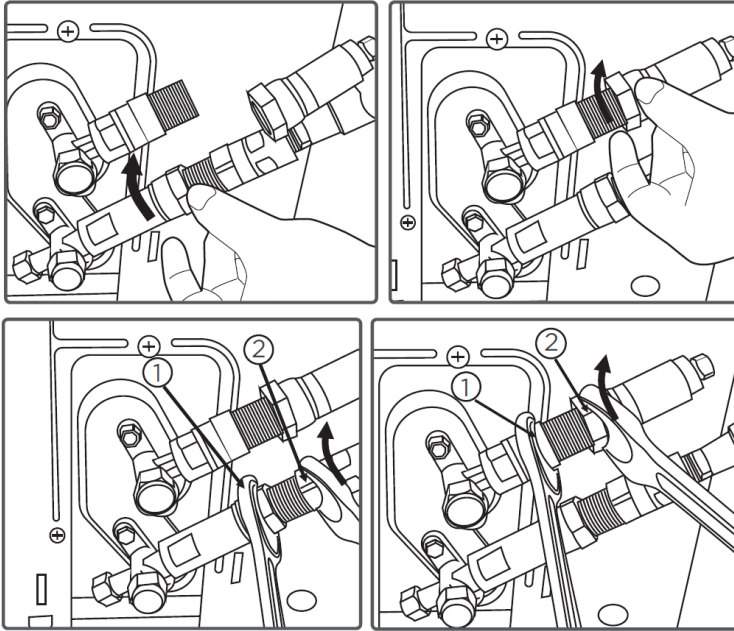

Step 3:

Work quickly, ensuring the screw connectors do not cross thread as they are tightened.

After completing steps 1-3, check that all connections are sealed correctly using a leak detection spray or soap suds. If any bubbles form, the system has a leak and the screw connectors must be retightened using an open-ended wrench.

NOTICE

Since the coupling works with tapping rings, it may leak if pipes are disconnected and reconnected. This will also void the warranty.

Step 4:

Remove the cover on the top valve using a 19mm open-ended wrench. Open the valve by turning it counter-clockwise as far as it will go using a 5mm Allen wrench. The valve is now open. If the valve is not fully opened, the system may malfunction and suffer damage. Screw the cover back onto the top valve and tighten it well to ensure that it is properly sealed.

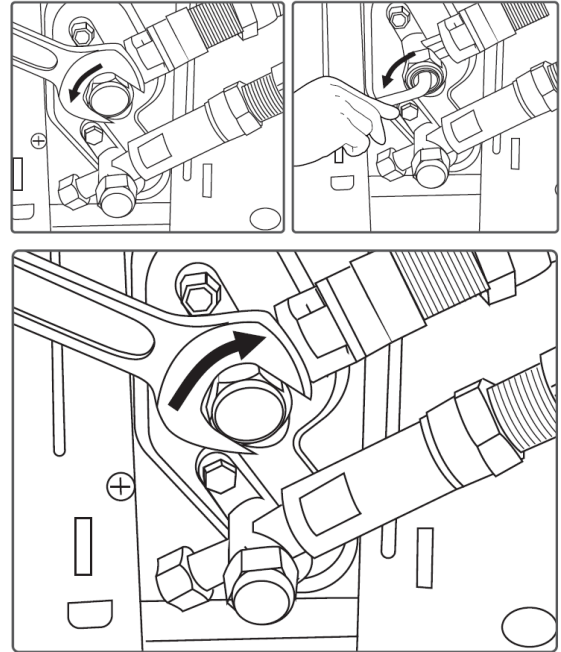

Step 5:

After the unit is installed, wrap the valve body with insulation material and ensure the valve is sealed.

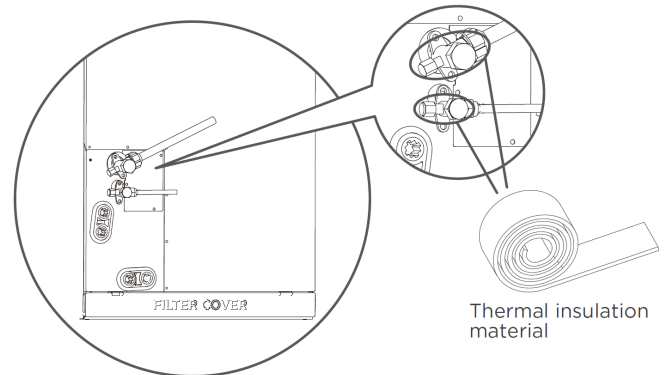

Torque Table

Coupling Size	Pound-Force-Foot (lbf-ft)	Kilogram-Force-Meter (kgf-cm)
-06 (9.5mm dash size)	18-20	180-200
-09 (12.7mm dash size)	32-39	320-390
-12 (19.1mm dash size)	49-59	490-590
-16 (25.4mm dash size)	57-71	570-710

5 ELECTRIC HEAT KIT INSTALLATION

5-Installation of Electric Auxiliary Heat Module

NOTICE

Installation must be performed by a licensed contractor. Please take necessary precautions when performing the installation.

Accessories

Name	Quantity
Manual	2
Foam Gasket	1
Screws	7
Silicone Breaker Cover	1
Electric Auxiliary Heating Wiring Diagram	1
Circuit Breaker Label	1

Model Size Selection

For installations requiring supplemental heating, the optional Electric Auxiliary Heat Module is available in sizes from 5kW to 25kW to accommodate appropriate sizing given the specific heat load and electrical requirements of each installation. Refer to the table below for selection of available sizes of each model, being sure to avoid improper matching.

Model (Btu/h)	5kW	8kW	10kW	15kW	20kW
18K	Y	Y	Y	-	-
24K	Y	Y	Y	Y	-
30K	Y	Y	Y	Y	-
36K	Y	Y	Y	Y	Y
48K	-	Y	Y	Y	Y
60K	-	-	Y	Y	Y

NOTICE

Only use compatible modules certified for use with the model. Refer to the Electric Auxiliary Heat Model specification for additional details to ensure proper selection and installation.

Installation Preparation

Before installation, confirm the electric auxiliary heat module and supplied accessories are present and free of damage. Do not attempt to install if damage is present.

Electric Auxiliary Heat Module Installation and Wiring Operation

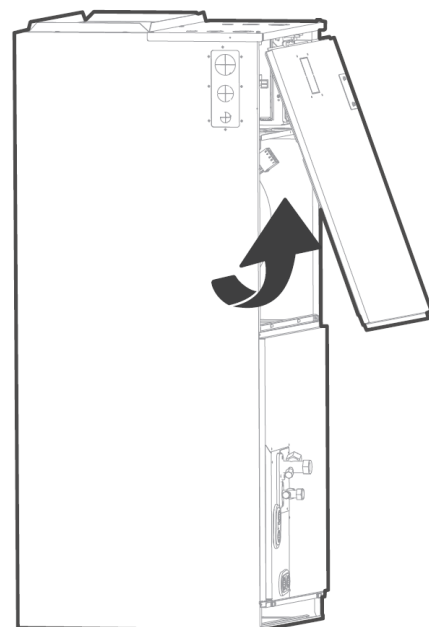

Step 1:
Open the upper cover.

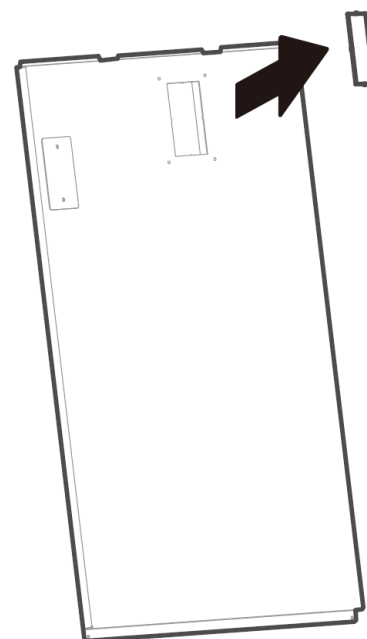

Step 2:
Use tools to remove the knock-out holes of the upper cover.

5 ELECTRIC HEAT KIT INSTALLATION

Step 3:

Remove the terminal block and power wires, loosen the screws, and remove the electric auxiliary heating cover.

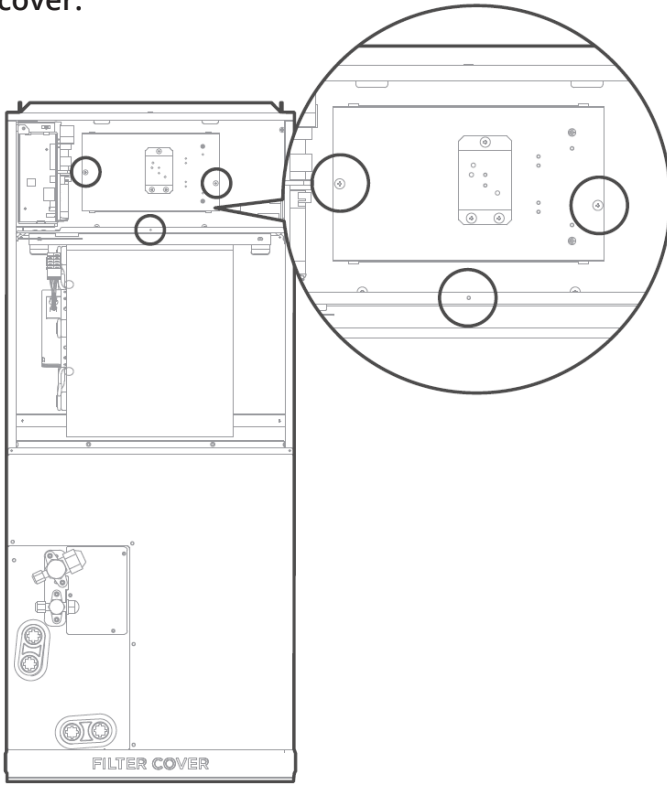

Step 4:

Install the electric auxiliary heating assembly through the front, and note that the support assembly must lock into the support holes in the back of the cabinet.

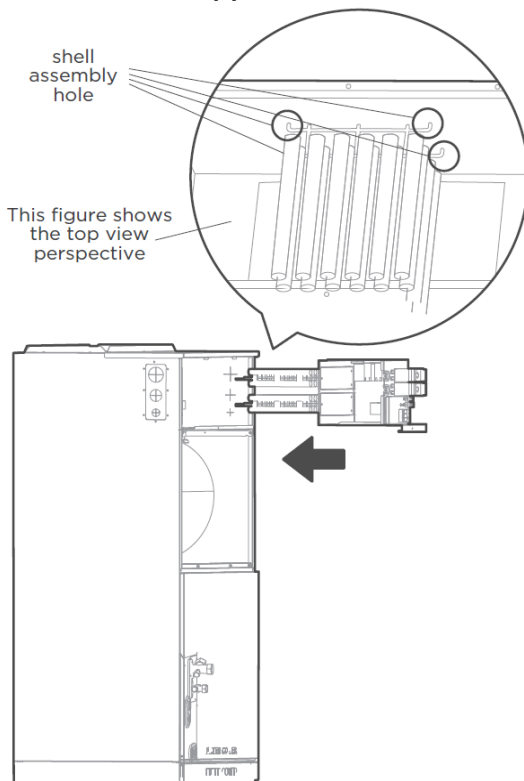

Step 5:

Tighten the mounting screws.

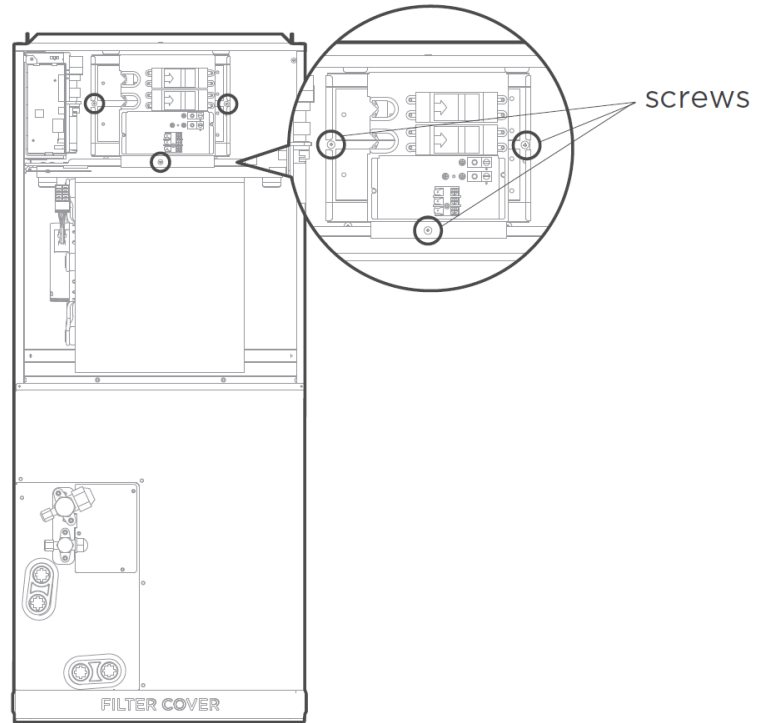

Step 6:

Wire according to the wiring nameplate. Apply the wiring diagram to the inside cover for future reference and maintenance.

Step 7:

Install the upper cover and the silicone breaker cover.

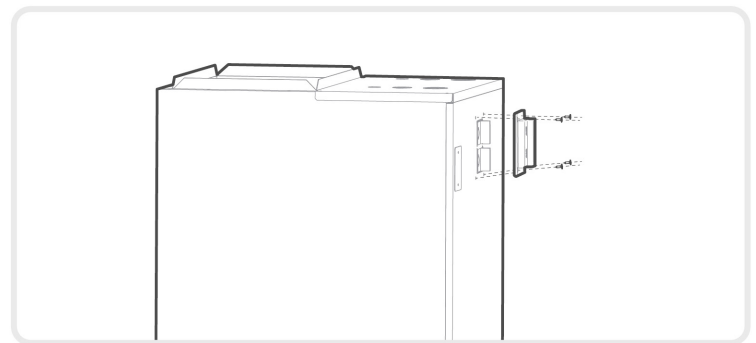

Step 8:

After installing the electric auxiliary heat module, apply the circuit breaker label near the silicone breaker cover previously installed.

6 CONFIRMATION OF INDOOR UNIT

6.1 Units with Electrical Heat

NOTICE

- The electric auxiliary heating wiring diagram is packed with the accessories.
- If the branch circuit wire length exceeds 100ft, consult NEC 210-19a to determine maximum wire length.
- Use 2% voltage drop.

After the electric heating wiring is connected, please confirm the following before powering on:

- Check and ensure a secure connection of all wiring.
- Ensure that wire size is properly selected per NEC or local codes.

Specifications	Number of Circuit Breakers	Number of Relays	Number of Power Cord Groups	Number of Power Cord Grounding Screws
5kW	1	1	2	2
8kW	1	2	2	2
10kW	1	2	2	2
15kW	2	3	3	3
20kW	2	4	3	3

6.2 Units without Electrical Heat

Unit Size	Volts-Phase	Rated Current (A)	Minimum Circuit Amps	Branch Circuit	
				Minimum Wire Size AWG	Fuse/Circuit Breaker Amps
18K	208/230-1	2.0	2.5	14#	15.0
24K	208/230-1	3.0	4.0	14#	15.0
30K	208/230-1	3.5	4.5	14#	15.0
36K	208/230-1	4.0	5.0	14#	15.0
48K	208/230-1	6.0	7.5	14#	15.0
60K	208/230-1	7.0	9.0	14#	15.0

Use copper wire only to connect unit. If other than uncoated (non-plated) 75°C copper wire (solid wire for 10 AWG and smaller, stranded wire for larger than 10 AWG) is used, consult applicable tables of the National Electric Code (ANSI/NFPA 70).

NOTICE

The specification may be different between different models. Refer to the indoor unit's nameplate. Choose the cable type according to the local electrical codes and regulations. Choose the correct cable size according to the Minimum Circuit Ampacity indicated on the nameplate of the unit.

6.3 Auxiliary Heater Electrical Data

Heater Model	Heater kW	Internal Circuit Protection	Circuit 1 208/230V			Circuit 2			Circuit 2		
			Heater Amps	MCA (1)	MOCP (2)	Heater Amps	MCA (1)	MOCP (2)	Heater Amps	MCA (1)	MOCP (2)
CENTRALHK05	5	Ckt Bkr	18.0/20.0	23.0/27.0	25.0/30.0	/	/	/	/	/	/
CENTRALHK08	8	Ckt Bkr	28.8/32.0	37.0/42.0	40.0/45.0	/	/	/	/	/	/
CENTRALHK10	10	Ckt Bkr	36.0/40.0	46.0/53.0	50.0/60.0	/	/	/	/	/	/
CENTRALHK15	15	Ckt Bkr	18.0/20.0	23.0/27.0	25.0/30.0	36.0/40.0	46.0/53.0	50.0/60.0	/	/	/
CENTRALHK20	20	Ckt Bkr	36.0/40.0	46.0/53.0	50.0/60.0	36.0/40.0	46.0/53.0	50.0/60.0	/	/	/

6 CONFIRMATION OF INDOOR UNIT

6.4 Electric Auxiliary Heating Wiring Diagrams

5KW HEAT KIT

- : THERMAL CUT-OUT(Cut-off temperature 98°C, holding temperature 83°C, limiting temperature 410°C.)
- : THERMAL LINK, SELF-RESETTING(Break-off temperature 60 ± 3°C, reset temperature 43 ± 6°C.)

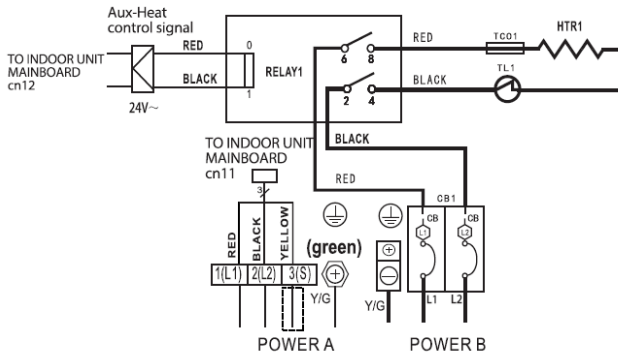

NOTE1: This symbol indicates the element is optional, The wiring type of the actual unit shall prevail.

NOTE2: Please attach the nameplate to the cover of the electric control box. All the round holes located on the plate represent numbers. Please refer to the Installation Manual for details.

Round hole number	Relay number	Round hole number	Circuit breaker number
○	RELAY1	○	CB1
○		○	
○		○	
○		○	

NOTE3: TO BE WIRED IN ACCORDANCE WITH NEC AND LOCAL CODES.

NOTE4: POWER A,B,C,D ARE DIFFERENT POWERS.

The wiring mode of power supply A shall be based on the type of original wiring terminal of AHU; for type A, S position must be connected to the outdoor S; for type B, S position shall not be connected.



8KW/10KW HEAT KIT

- : THERMAL CUT-OUT(Cut-off temperature 98°C, holding temperature 83°C, limiting temperature 410°C.)
- : THERMAL LINK, SELF-RESETTING(Break-off temperature 60 ± 3°C, reset temperature 43 ± 6°C.)

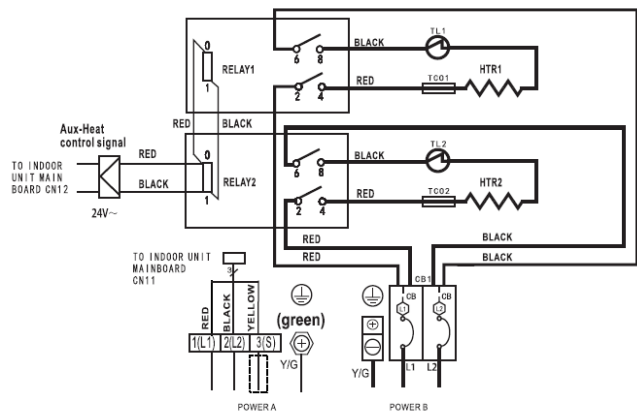

NOTE1: This symbol indicates the element is optional, The wiring type of the actual unit shall prevail.

NOTE2: Please attach the nameplate to the cover of the electric control box. All the round holes located on the plate represent numbers. Please refer to the Installation Manual for details.

Round hole number	Relay number	Round hole number	Circuit breaker number
○	RELAY1	○	CB1
○	RELAY2	○	
○		○	
○		○	

NOTE3: TO BE WIRED IN ACCORDANCE WITH NEC AND LOCAL CODES.

NOTE4: POWER A,B,C,D ARE DIFFERENT POWERS.

The wiring mode of power supply A shall be based on the type of original wiring terminal of AHU; for type A, S position must be connected to the outdoor S; for type B, S position shall not be connected.

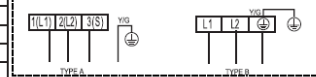

15KW HEAT KIT

- : THERMAL CUT-OUT(Cut-off temperature 98°C, holding temperature 83°C, limiting temperature 410°C.)
- : THERMAL LINK, SELF-RESETTING(Break-off temperature 60 ± 3°C, reset temperature 43 ± 6°C.)

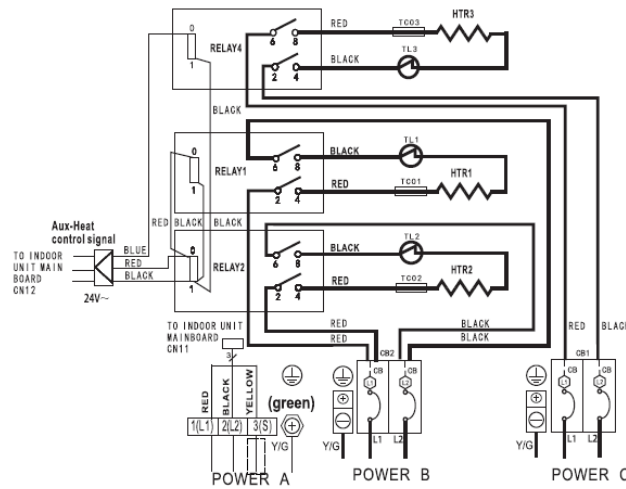

NOTE1: This symbol indicates the element is optional, The wiring type of the actual unit shall prevail.

NOTE2: Please attach the nameplate to the cover of the electric control box. All the round holes located on the plate represent numbers. Please refer to the Installation Manual for details.

Round hole number	Relay number	Round hole number	Circuit breaker number
○	RELAY1	○	CB1
○	RELAY2	○	CB2
○	RELAY4	○	
○		○	

NOTE3: TO BE WIRED IN ACCORDANCE WITH NEC AND LOCAL CODES.

NOTE4: POWER A,B,C,D ARE DIFFERENT POWERS.

The wiring mode of power supply A shall be based on the type of original wiring terminal of AHU; for type A, S position must be connected to the outdoor S; for type B, S position shall not be connected.



20KW HEAT KIT

- : THERMAL CUT-OUT(Cut-off temperature 98°C, holding temperature 83°C, limiting temperature 410°C.)
- : THERMAL LINK, SELF-RESETTING(Break-off temperature 60 ± 3°C, reset temperature 43 ± 6°C.)

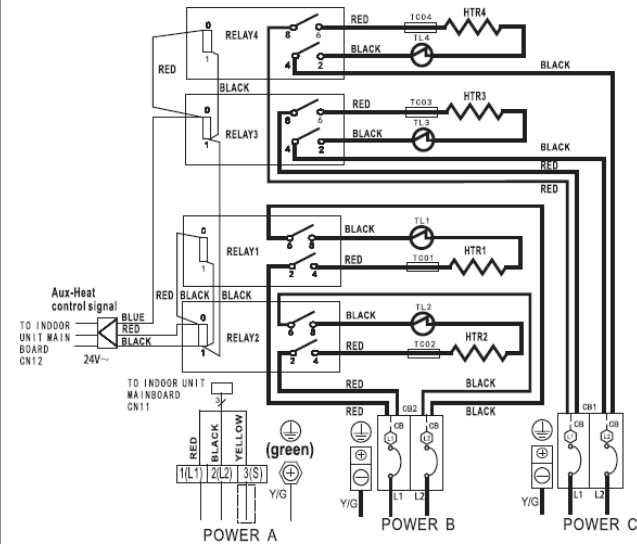

NOTE1: This symbol indicates the element is optional, The wiring type of the actual unit shall prevail.

NOTE2: Please attach the nameplate to the cover of the electric control box. All the round holes located on the plate represent numbers. Please refer to the Installation Manual for details.

Round hole number	Relay number	Round hole number	Circuit breaker number
○	RELAY1	○	CB1
○	RELAY2	○	CB2
○	RELAY3	○	
○	RELAY4	○	

NOTE3: TO BE WIRED IN ACCORDANCE WITH NEC AND LOCAL CODES.

NOTE4: POWER A,B,C,D ARE DIFFERENT POWERS.

The wiring mode of power supply A shall be based on the type of original wiring terminal of AHU; for type A, S position must be connected to the outdoor S; for type B, S position shall not be connected.



6 CONFIRMATION OF INDOOR UNIT

25KW HEAT KIT

—○— : THERMAL CUT-OUT(Cut-off temperature 98℃, holding temperature 83℃, limiting temperature 410℃.)

—○— : THERMAL LINK, SELF-RESETTING(Break-off temperature 60 ± 3℃, reset temperature 43 ± 6℃.)

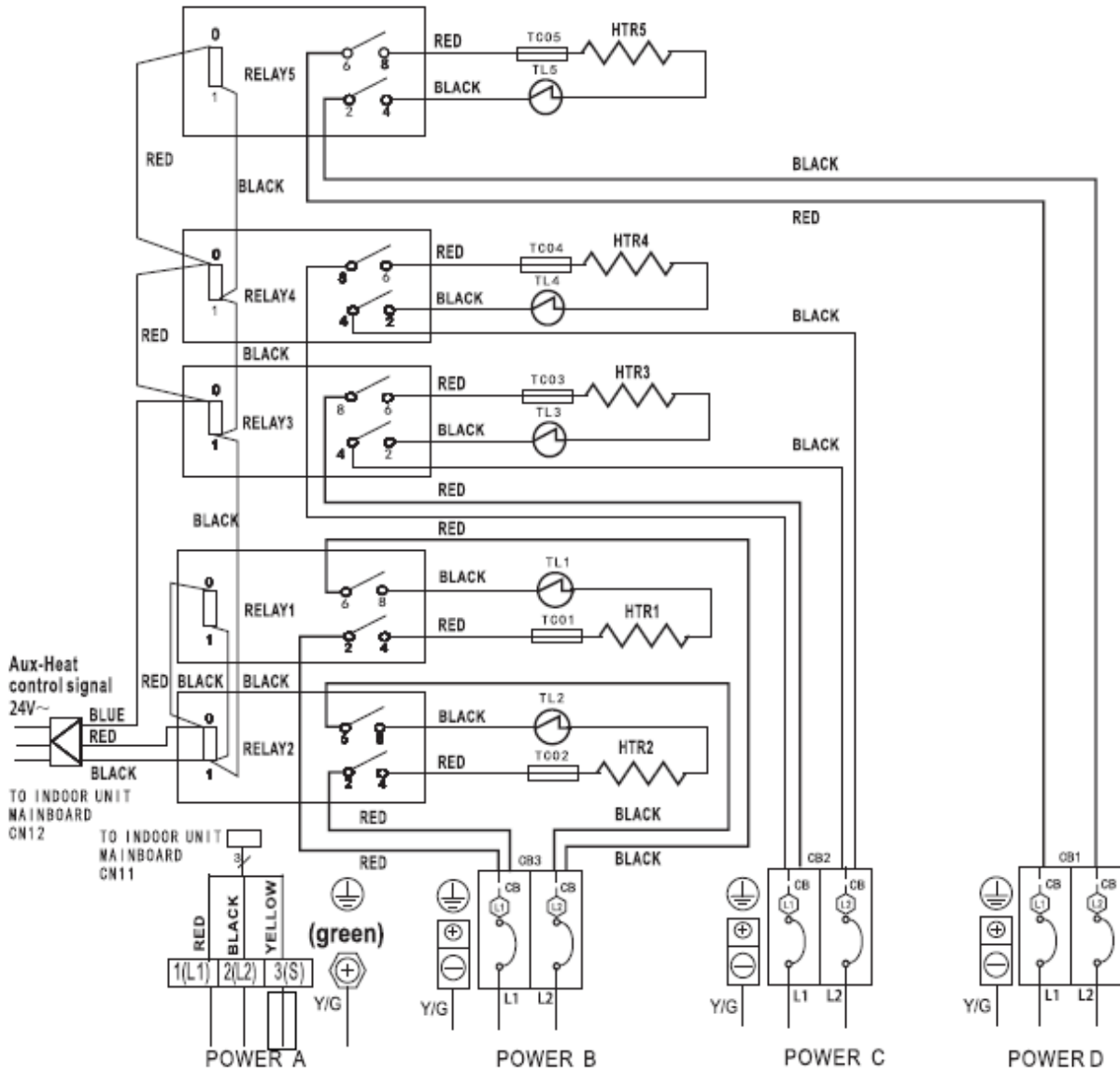

NOTE1: □
This symbol indicates the element is optional, The wiring type of the actual unit shall prevail.

NOTE2:
Please attach the nameplate to the cover of the electric control box. All the round holes located on the plate represent numbers. Please refer to the Installation Manual for details.

NOTE3: TO BE WIRED IN ACCORDANCE WITH NEC AND LOCAL CODES.

NOTE4: POWER A,B,C,D ARE DIFFERENT POWERS.

Round hole number	Relay number	Round hole number	Circuit breaker number
○	RELAY1	○	CB1
○○	RELAY2	○○	CB2
○○○	RELAY3	○○○	CB3
○○○○	RELAY4		
○○○○○	RELAY5		

The wiring mode of power supply A shall be based on the type of original wiring terminal of AHU; for type A, S position must be connected to the outdoor S; for type B, S position shall not be connected.



7 OUTDOOR UNIT INSTALLATION

NOTICE

Install the unit by following local switch regulations. These may differ slightly between different regions.

7.1 Outdoor Unit Location Selection

Before installing the outdoor unit, you must choose an appropriate location. The following are standards to help choose an appropriate location for the unit.

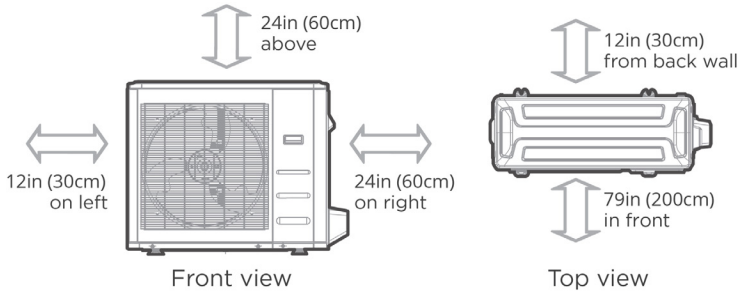

Meets all spatial requirements shown in installation Space Requirements above.



Firm & Solid--the location can support the unit and will not vibrate.



Noise from the unit will not disturb other people.

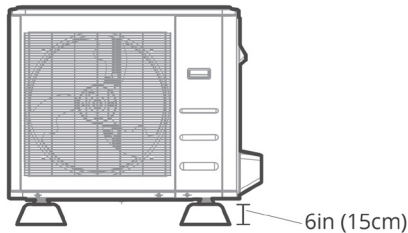

The outdoor unit must be installed on riser of at least 6in (15cm) in height or per local code to get the unit above local mean snow fall.



Good air circulation and ventilation.

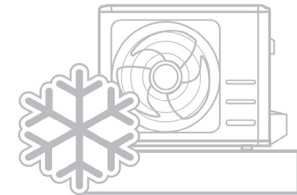

Where snowfall is anticipated, take appropriate measures to prevent ice buildup and coil damage.

Do NOT install the unit in the following locations:

- Near an obstacle that will block air inlets and outlets.
- In a location that is exposed to large amounts of dust.
- Near animals or plants that will be harmed by hot air discharge.
- Near any source of combustible gas.
- Near a public street, crowded areas, or where noise from the unit can disturb others.

! CAUTION FOR EXTREME WEATHER

If the unit is exposed to heavy wind, install so that the air outlet fan is at a 90° angle to the direction of the wind. If needed, build a barrier in front of the unit to protect it from extremely heavy winds. See figures below. If the unit is frequently exposed to heavy rain or snow, build a shelter above the unit to protect it from the rain or snow. Be careful not to obstruct air flow around the unit.

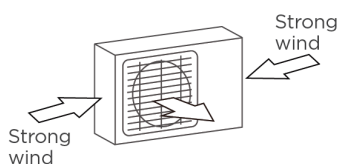

90° angle to the direction of the wind

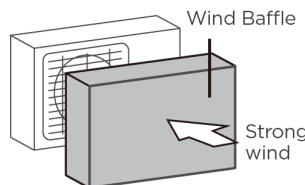

Build a wind Baffle to protect the unit

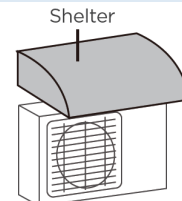

Build a shelter to protect the unit

7 OUTDOOR UNIT INSTALLATION

7.2 Drain Fitting Installation

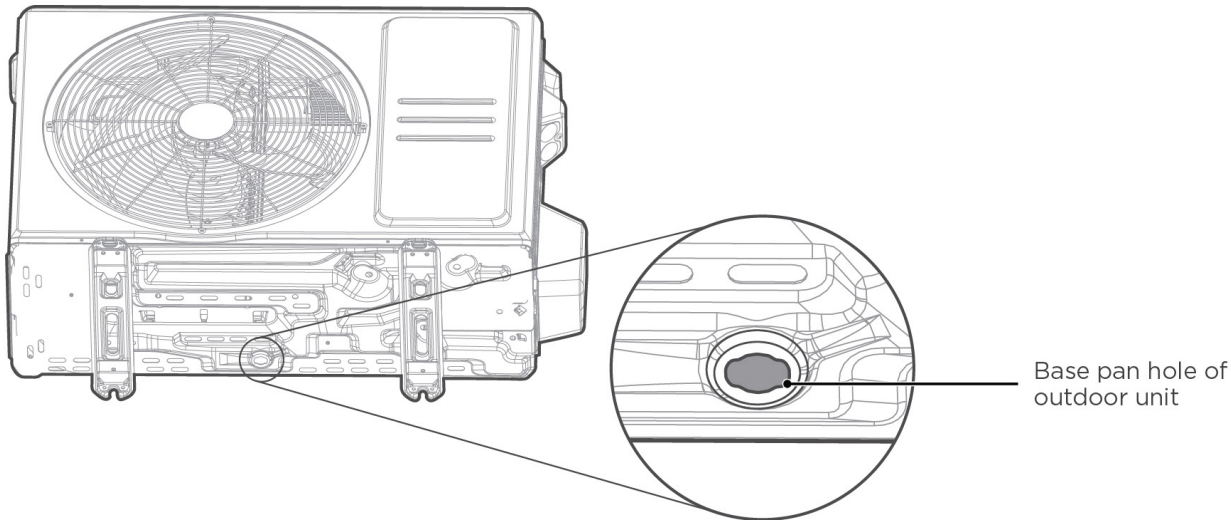

Step 1:

Find the base pan hole on the outdoor unit.

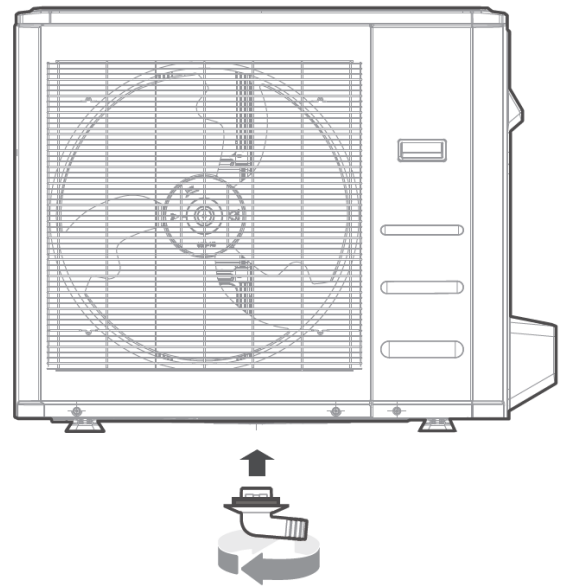
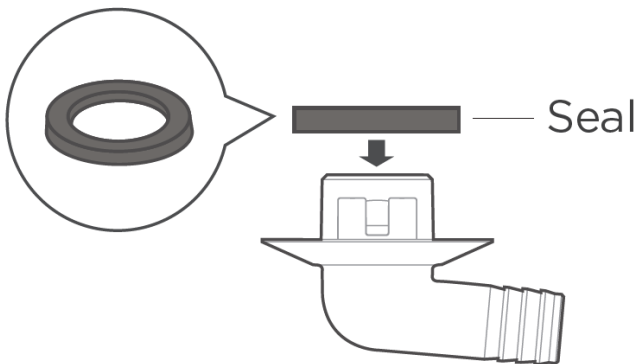

Step 2:

- Fit the rubber seal on the end of the drain fitting that will connect to the outdoor unit.
- Insert the drain fitting into the hole in the base pan of the unit. The drain fitting will click into place.
- Connect a drain hose extension (not included) to the drain fitting to redirect water from the unit during heating mode.

IN COLD CLIMATES

In cold climates, make sure that the drain hose is as vertical as possible to ensure swift water drainage. If water drains too slowly, it can freeze inside the hose and flood the unit.

7 OUTDOOR UNIT INSTALLATION

7.3 Anchor Outdoor Unit

The outdoor unit can be anchored to the ground or to a wall-mounted bracket with an M10 bolt. Prepare the installation base of the unit according to the dimensions below.

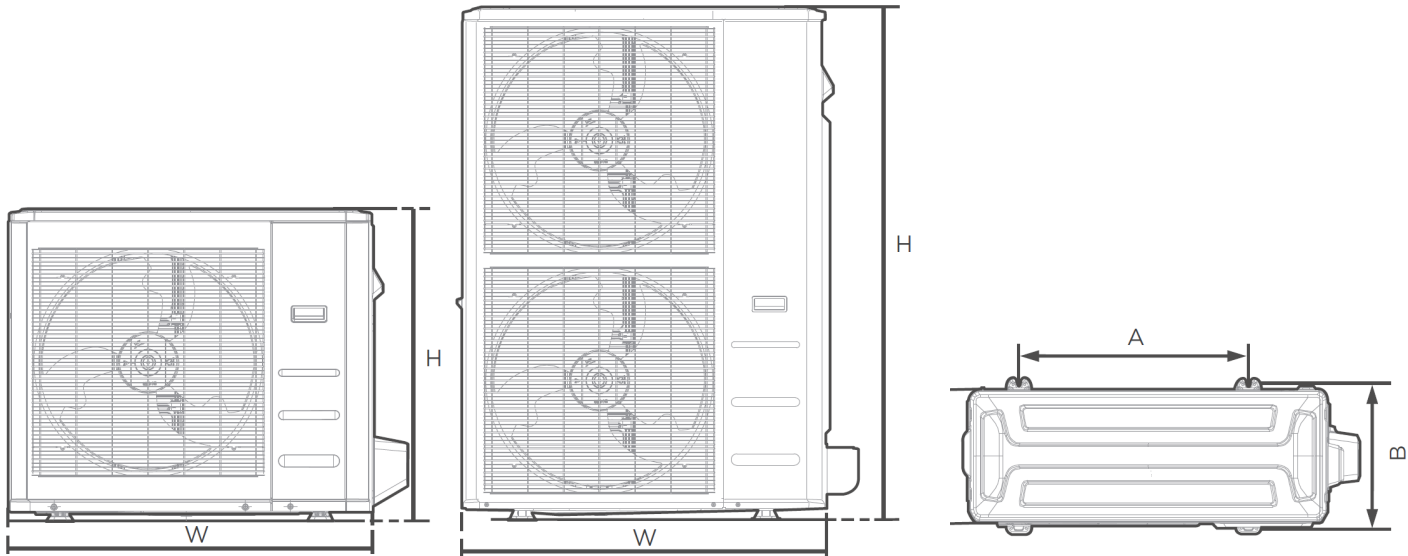

Front view

Top view

Model	Outdoor Unit Dimensions						Mounting Dimensions			
	W		H		D		A		B	
	mm	inch	mm	inch	mm	inch	mm	inch	mm	inch
18K	890	35	673	26-1/2	342	13-15/32	663	26-1/8	354	13-15/16
24K/30K/36K	946	37-1/4	810	31-29/32	410	16-5/32	673	26-1/2	403	15-7/8
48K/60K	952	37-1/2	1333	52-1/2	415	16-11/32	634	24-35/36	404	15-29/32

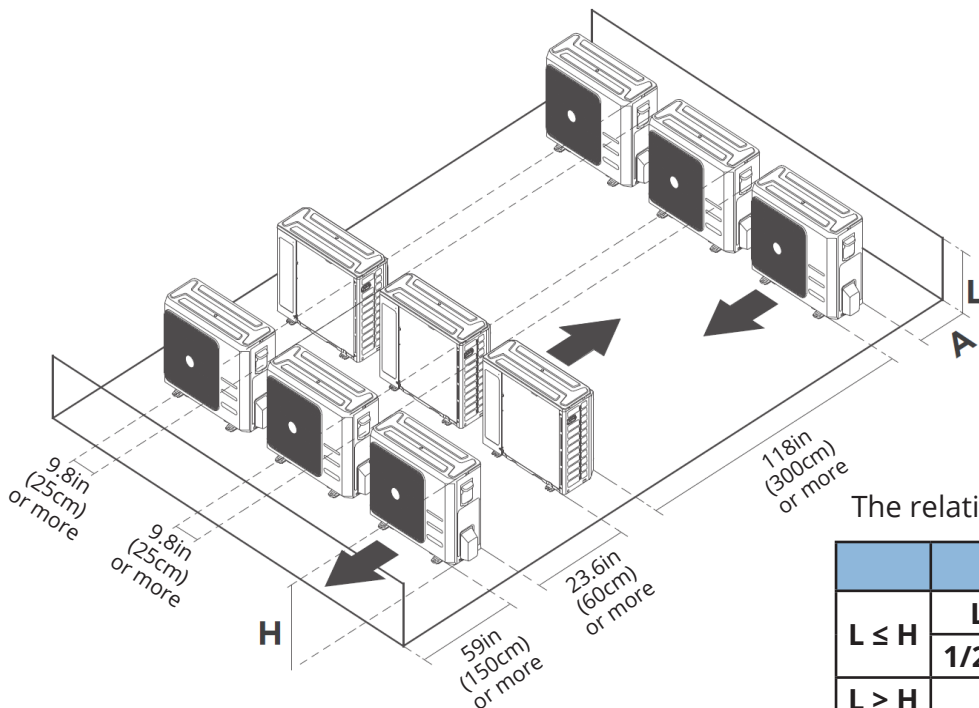

Rows of Series Installation

The relations between H, A, and L are as follows:

	L	A
L ≤ H	L ≤ 1/2H	25cm / 9-13/16in or more
	1/2H < L ≤ H	30cm / 11-13/16in or more
L > H	Cannot be installed	

7 OUTDOOR UNIT INSTALLATION

If installing the unit on the ground or concrete mounting platform, do the following:

- Mark the positions for four expansion bolts based on the dimensions chart.
- Pre-Drill holes for expansion bolts.
- Place a nut on the end of each expansion bolt.
- Hammer expansion bolts into the pre-drilled holes.
- Remove the nuts from expansion bolts, and place the outdoor unit on bolts.
- Put a washer on each expansion bolt, then replace the nuts.
- Using a wrench, tighten each nut until snug.



WARNING

WHEN DRILLING INTO CONCRETE, EYE PROTECTION IS RECOMMENDED AT ALL TIMES.

If installing the unit on a wall-mounted bracket, do the following:

- Mark the position of the bracket holes based on the dimensions chart.
- Pre-Drill holes for expansion bolts.
- Place a washer and nut on the end of each expansion bolt.
- Thread expansion bolts through the holes in the mounting brackets, put mounting brackets into position, and hammer the expansion bolts into the wall.
- Check that the mounting brackets are level.
- Carefully lift the unit and place its mounting feet on brackets.
- Bolt the unit firmly to the brackets.
- If allowed, install the unit with rubber isolator pads to reduce vibrations and noise.

CAUTION

Make sure the wall is made of solid brick, concrete, or of similarly strong material. The wall must be able to support at least four times the weight of the unit.

7 OUTDOOR UNIT INSTALLATION

7.4 Connecting Quick-Connect Refrigerant Lines

NOTICE

All pictures are for explanatory purposes only. The actual shape of your outdoor unit may be slightly different.

Step 1:

Remove the service valve cover on the outdoor unit as shown below.

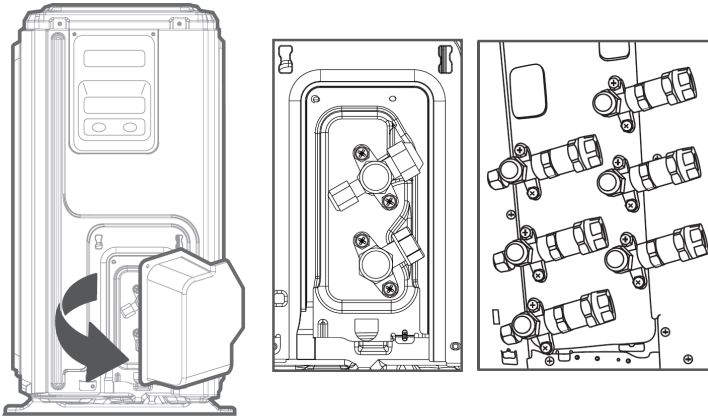

remove the cover

Model A

Model B

Step 2:

When immediately read to install the refrigerant line, remove the plastic seals/caps from the outdoor unit and refrigerant line.

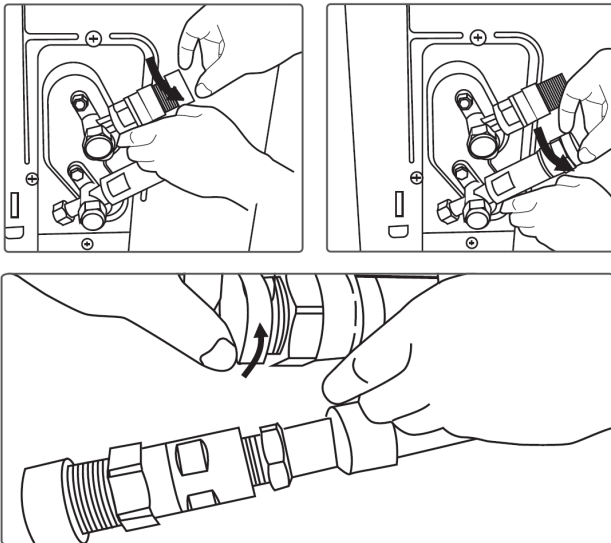

Step 3:

Align the refrigerant quick-connect line with the threaded connector on the outdoor unit, ensuring they are the same size. Being careful not to cross-thread, screw the line connector onto the quick-connect and hand-tighten.

NOTICE

The refrigerant pipes must be connected to the valves on the outdoor unit with as little stress as possible.

IMPORTANT: Before continuing, it is essential to read the following instructions carefully.

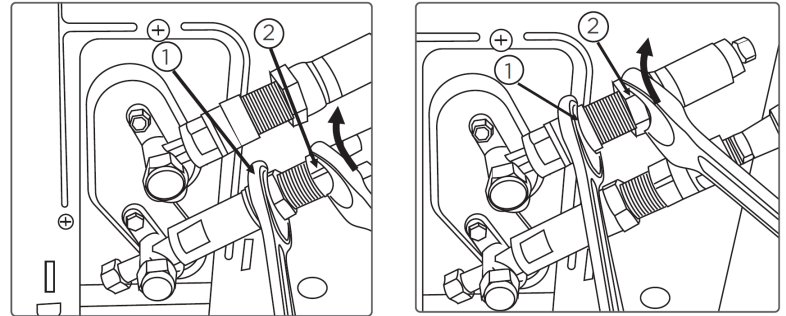

Step 4:

Using two open-ended wrenches, tighten the quick-connect nut 2 on the line according to the torque specification in the table below, being careful not to loosen connection 1 to the valve body.

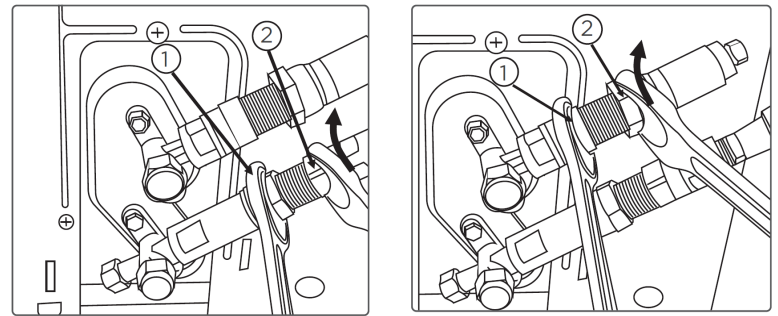

Coupling Size	Pound-Force-Foot (lbf-ft)	Newton Meter (N-m)	Kilogram-Force-Meter (kgf-m)
-06 (9.5mm dash size)	18-20	24.4-27.1	2.4-2.7
-09 (12.7mm dash size)	30-35	40.6-47.4	4.1-4.8
-12 (19.1mm dash size)	45-50	61.0-67.7	6.2-6.9
-16 (25.4mm dash size)	60-65	81.3-88.1	8.2-8.9

Step 5:

After completing steps 1-4, check that all the connections are sealed correctly using leak detection spray or soap suds. If any bubbles form, the system has a leak and the screw connectors must be retightened using an open-ended wrench.

7 OUTDOOR UNIT INSTALLATION

Step 6:

Remove the cover on the top valve using a 19mm open-ended wrench. Open the valve by turning it counter-clockwise as far as it will go using a 5mm Allen key. The valve is now open. If the valve is not opened fully, the system may malfunction and suffer damage. Screw the cover back onto the top valve and tighten it well to ensure that it is properly sealed.

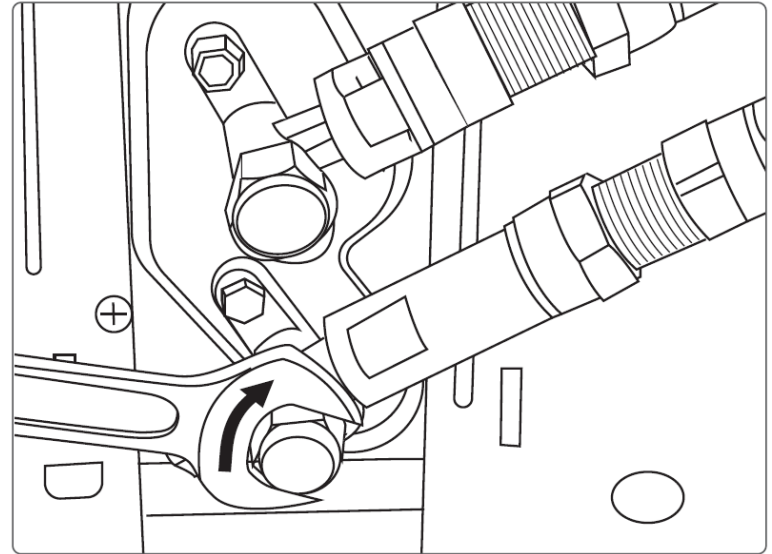
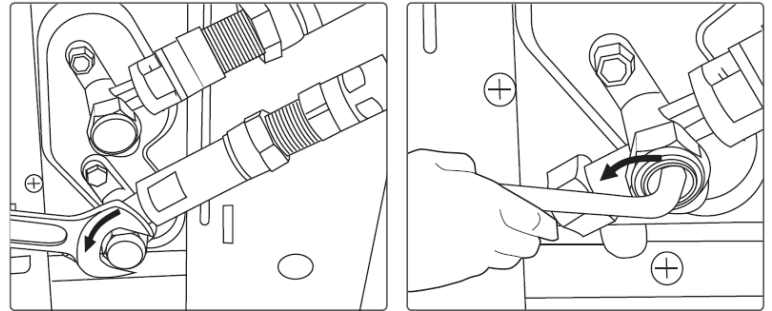
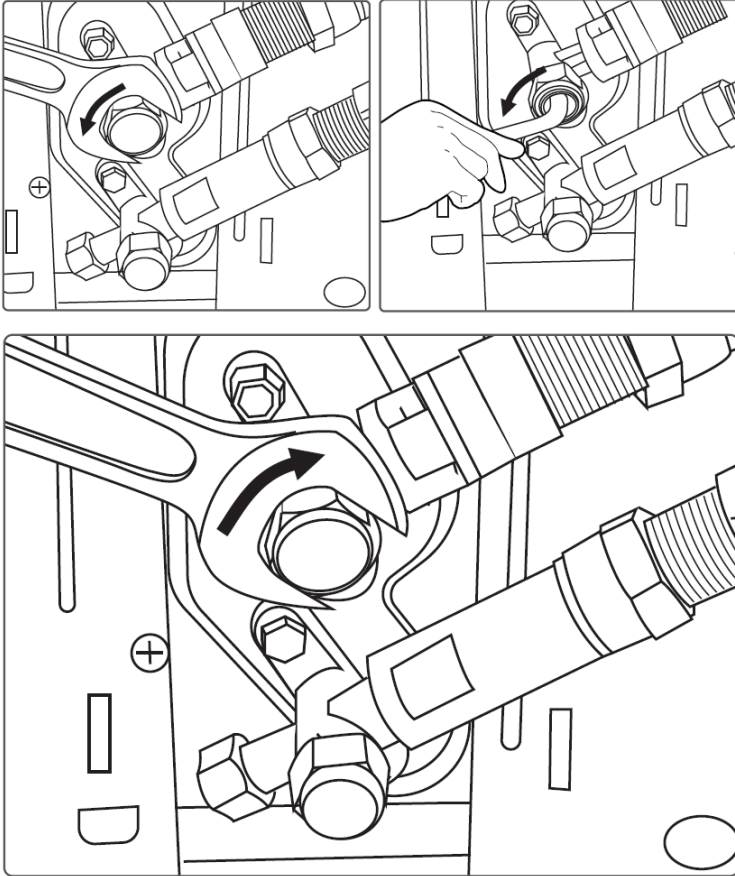

NOTICE

IMPORTANT: The conical ring on the valve has an important sealing function together with the sealing seat in the caps. Ensure that you do not damage the cone and that you keep the cap free of dirt and dust.

Step 7:

Remove the cover on the bottom valve using a 19mm open-ended wrench. Open the valve by turning it counter-clockwise as far as it will go using a 5mm Allen key. The valve is now open. If the valve is not opened fully, the system may malfunction and suffer damage. Screw the cover back onto the bottom valve and tighten it well to ensure that it is properly sealed.

Step 8:

After completing steps 1-7, check that all the connections are sealed correctly using leak detection spray or soap suds. If any bubbles form, the system has a leak and the screw connectors must be retightened using an open-ended wrench.

Step 9:

With the system now functional, check the system again for signs of leaks (as in step 7) except while operating in both cooling and heating modes to allow proper operating pressures to be generated. If any bubbles form, the system has a leak and the new screw connectors must be retightened until no leak exists. If problems persist or for any questions about the installation or connection of the refrigerant lines, contact the customer service team or a licensed HVAC contractor.

8 ELECTRICAL CONNECTIONS

8.1 Wiring Precautions



WIRING WARNINGS

Before performing any electrical work, read these warnings:

- **BEFORE PERFORMING ANY ELECTRICAL OR WIRING WORK, TURN OFF THE MAIN POWER TO THE SYSTEM.**
- All wiring must comply with local and national electrical codes, regulations, and must be installed by a licensed electrician.
- All electrical connections must be made according to the Electrical Connection Diagram located on the panels of the indoor and outdoor units.
- If there is a serious safety issue with the power supply, stop work immediately. Do not resume the install until the safety issue is properly resolved.
- Power voltage should be within 90-110% of rated voltage. Insufficient power supply can cause malfunction, electrical shock, or fire.
- Installation of an external surge suppressor at the outdoor disconnect is recommended.
- If connecting power to fixed wiring, a switch or circuit breaker that disconnects all poles and has a contact separation of at least 1/8in (3mm) must be incorporated in the fixed wiring. The qualified technician must use an approved circuit breaker or switch.
- Only connect the unit to an individual branch circuit. Do not connect another appliance to that circuit.
- Make sure to properly ground the unit.
- Every wire must be firmly connected. Loose wiring can cause the terminal to overheat, resulting in product malfunction and possible fire.
- Do not let wires touch or rest against refrigerant tubing, the compressor, or any moving parts within the unit.
- To avoid getting electric shock, never touch the electrical components soon after the power supply has been turned off. After turning off the power, always wait 10 minutes or more before you touch the electrical components.
- Ensure electrical wiring does not cross with signal wiring. This may cause distortion, interference, or possibly damage the circuit boards.
- No other equipment should be connected to the same power circuit.
- Connect the outdoor wires before connecting the indoor wires.

8.2 Wiring Overview

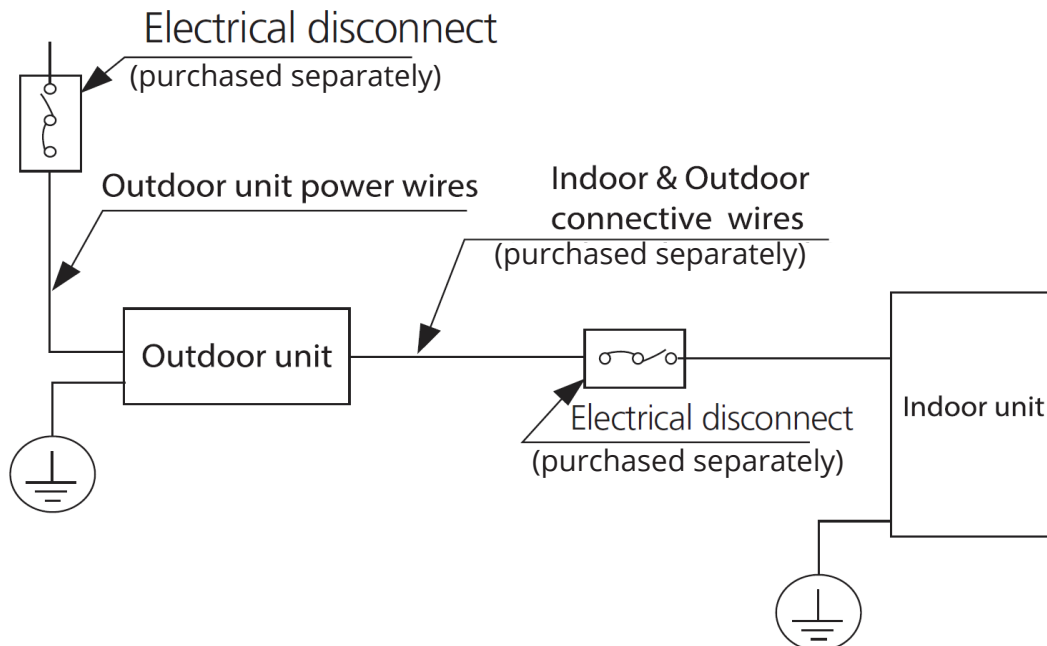

The diagrams are for explanation purpose only. Individual units may be slightly different. The actual diagram shall prevail.

8.3 Outdoor Unit Wiring

WARNING

BEFORE PERFORMING ANY ELECTRICAL OR WIRING WORK, TURN OFF THE MAIN POWER TO THE SYSTEM.

Prepare the cable for connection

Step 1:

1. Choose the right cable size according to the local electrical codes and regulations, and the Minimum Circuit Ampacity indicated on the unit nameplate.
2. Using wire strippers, strip the jacket from the both ends of the signal cable to reveal approximately 5.9in (15cm) of wire.
3. Strip the insulation from the ends.
4. Using a wire crimper, crimp u-lugs on the ends.

NOTICE

When connecting the wires, strictly follow the wiring diagram found inside the electrical box cover.

Step 2:

Remove the electrical box cover of the outdoor unit. IF there is no cover on the outdoor unit, take off the bolts from the maintenance board and remove the protection board.

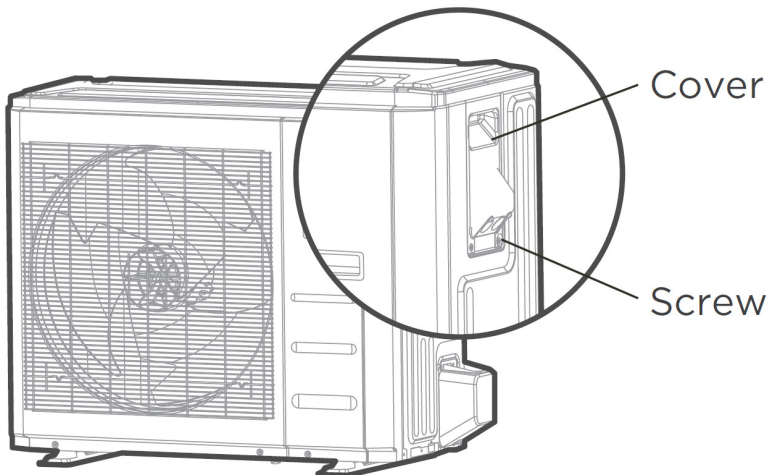

Step 3:

1. Match the wire colors/labels with the labels on the terminal block. Firmly screw the u-lug of each wire to its corresponding terminal.
2. Clamp down the cable with the cable clamp.
3. Insulate unused wires with electrical tape. Keep them away from any electrical or metal parts.
4. Reinstall the cover of the electrical control box.

Unit Wiring

Step 1:

Unscrew the electrical wiring cover and remove it. Connect the sheathed wire as shown below.

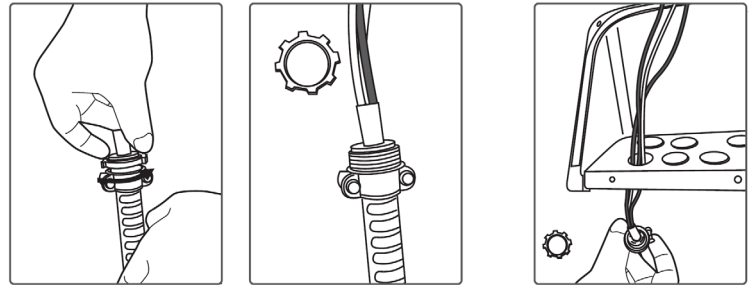

Remove the ring by turning counterclockwise.

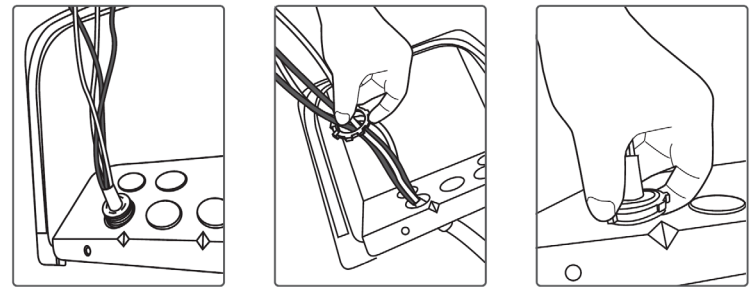

Reinstall the ring and attach it by turning it clockwise.

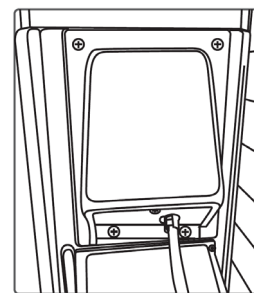

Replace the wire cover on the side of the unit, and screw it in place.

WARNING

- RISK OF ELECTRIC SHOCK CAN CAUSE INJURY OR DEATH. DISCONNECT ALL REMOTE ELECTRIC POWER SUPPLIES BEFORE SERVICING.
- ISOLATE THE POWER SUPPLY LEADS AND COMMUNICATION LEADS BY THE STRAIN RELIEF AND KEEP POWER SUPPLY LEADS AWAY FROM COMMUNICATION LEADS.

8.4 Indoor Unit Wiring



WARNING

ISOLATE THE POWER SUPPLY LEADS AND COMMUNICATION LEADS BY THE STRAIN RELIEF AND KEEP POWER SUPPLY LEADS AWAY FROM COMMUNICATION LEADS.

Installation of DIYPRO cable

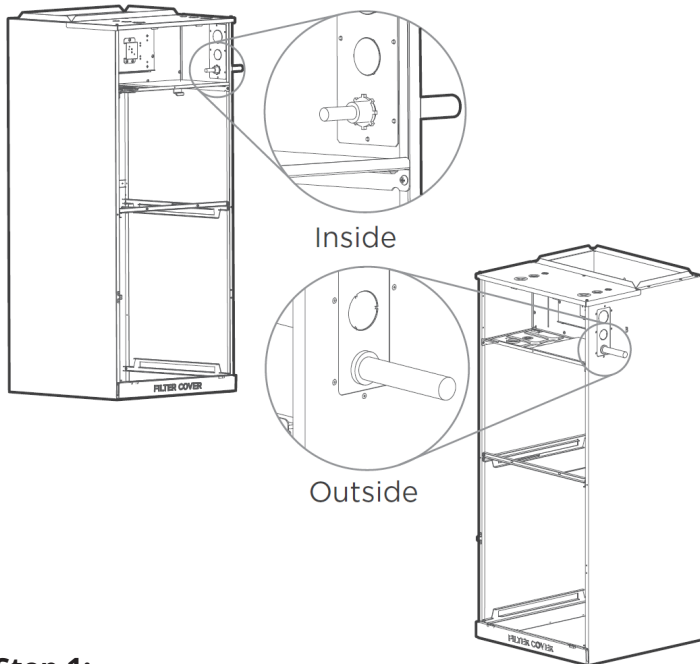

Step 1:

1. Unscrew the electrical wiring cover and remove it.
2. Pass the power cord through the knockout hole of the unit.
3. Assemble the cover to the power cord from the other side of the chassis and tighten it.

Indoor Unit Wiring

Step 1: Prepare the cable for connection.

1. Using wire strippers, strip the rubber jacket from both ends of the signal cable to reveal about 5.9in (15cm) of the wire.
2. Strip the insulation from the ends of the wires.

Step 2: Open the front panel.

1. Open the front panel of the indoor unit. Using a screwdriver, remove the cover of the electric control box on your indoor unit.
2. Thread the power cable and the signal cable through the wire outlet.

Step 3: Connect the wires to the terminals.

Match the wire colors/labels with the labels on the terminal block. Firmly screw the wires of each wire to its corresponding terminal. Refer to the Serial Number and Wiring Diagram located on the cover of the electric control box.

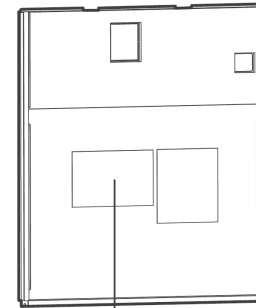

Wiring diagram

Type A

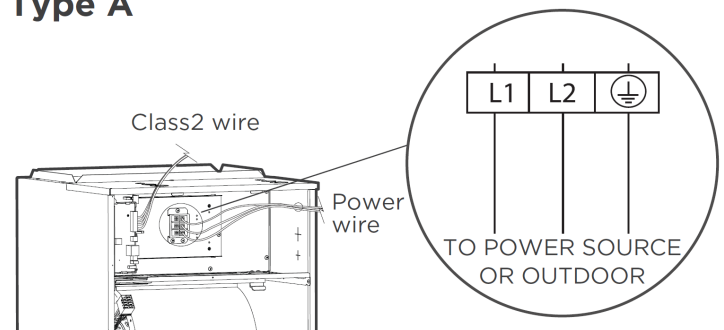

Type B

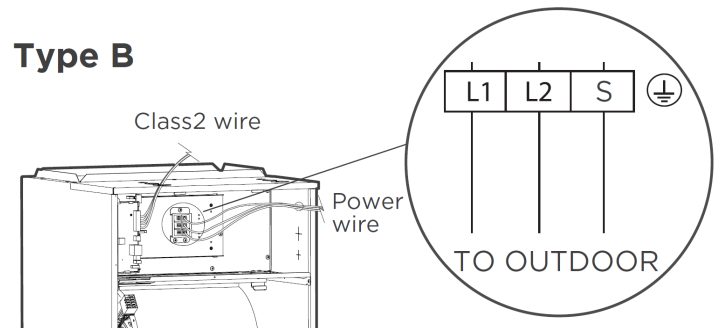

Step 4: Reattach the electric box cover.

Clamp down the cable with the cable clamp. The cable must not be loose or pull on the u-lugs. Reattach the electric box cover.



CAUTION

- While connecting the wires, strictly follow the wiring diagram.
- The refrigerant circuit can become very hot. Keep the interconnection cable away from the copper tube.

8.5 Specific Wiring Methods



WARNING

Refer to the wiring nameplate for the wiring method. Do not connect the power cord to the communication line, as this may damage the system.

Connection Method:

Refer to the wiring method of internal and external machine communication and wired controller as follows:

(A)

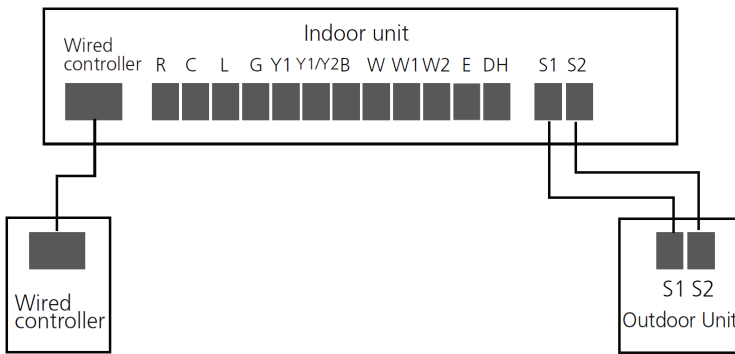

(B)

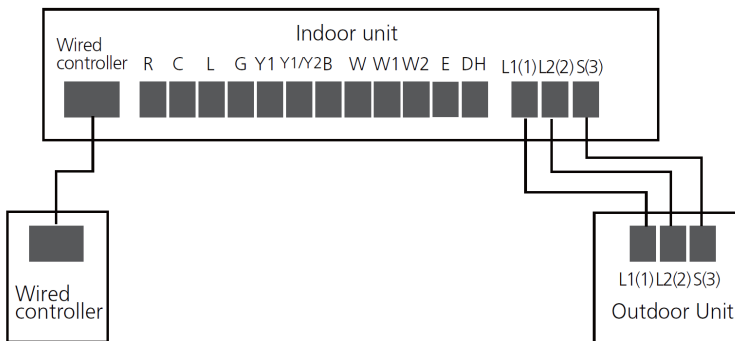

If utilizing a 3rd-party thermostat, follow the wiring diagram C below:

(C)

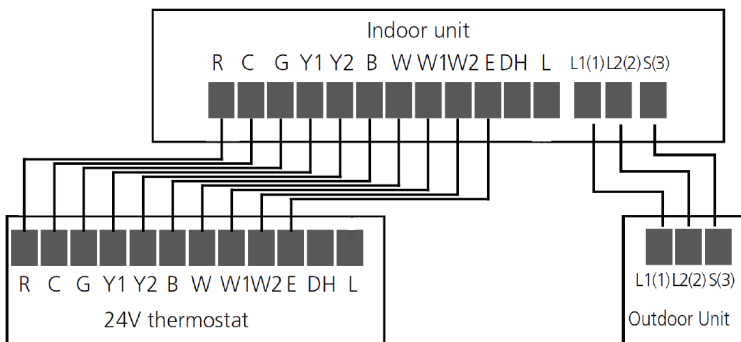

Optional Function Wiring:

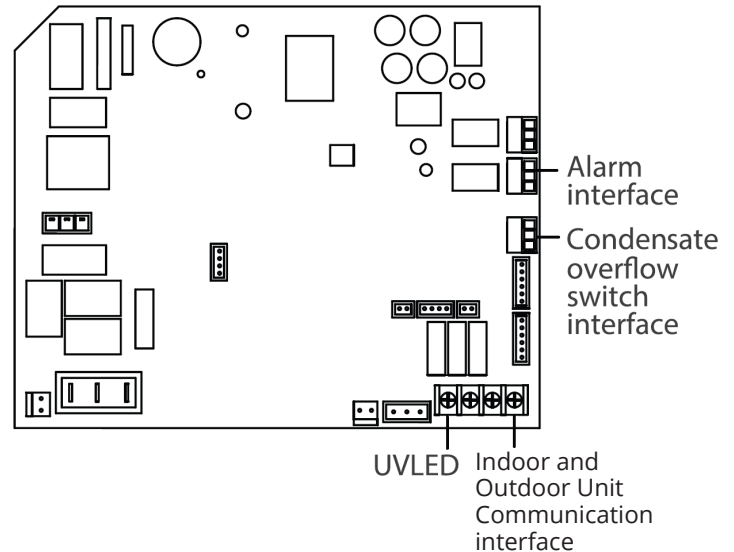

Condensate Overflow Switch:

The unit will accommodate a remote condensate overflow switch. To enable, remove jumper J1 and connect the installer-provided condensate overflow device to CN5 per below. When an overflow condition is present, the device should open connection signaling the unit to turn off the system.

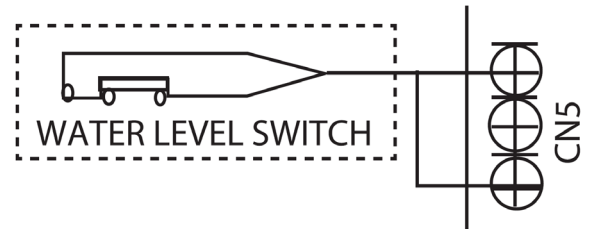

Fault Warning:

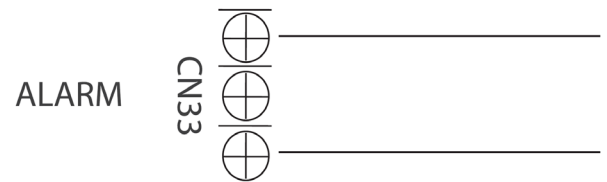

Alarm Output:

An alarm output (CN33) can be utilized if actions are required when a fault is present. This is a passive outlet port, so you will need to input a voltage signal. The relay is normally open for normal operation, and closed when a fault condition is active.

Humidifier Control:

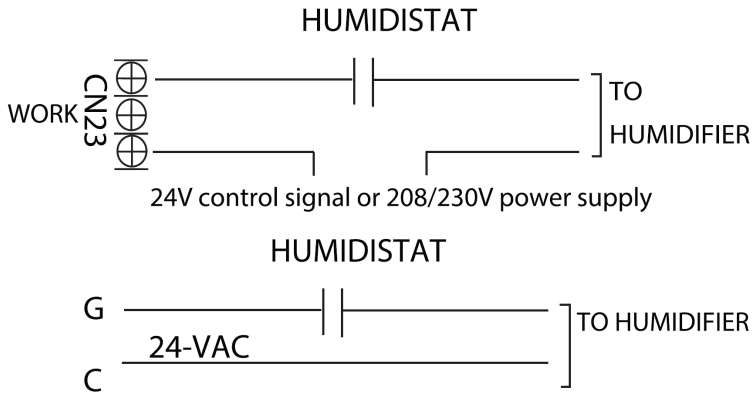

To connect a humidifier, utilize the passive signal “WORK” output (CN23) port as well as the G and C wires on the controller, and wire the humidistat and humidifier per above wiring diagram. When the fan is running, the CN23 relay will be closed, which will allow power to the humidifier when the humidistat is below the humidity setpoint. If the thermostat or zone controller has an HUM interface, connect the humidifier directly to the HUM and C ports.

Dehumidification Control Wiring

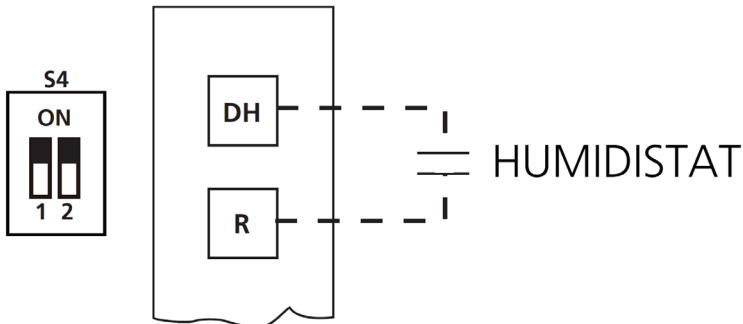

Dehumidification control requires external Humidistat at DH and R. Set S4-2 as OFF. When the humidity rises and exceeds the set value of the Humidistat, the 24V signal of DH changes to 0V, the cooling system starts the dehumidification operation, and the air volume drops to 80% of the nominal cooling air volume.

UV, Fresh Air, or Ion Generator Wiring

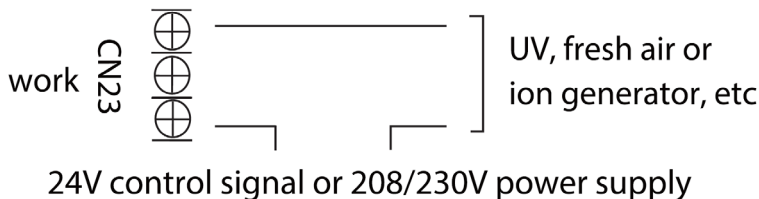

The WORK port is linked with the fan. When the fan is running, the relay is closed; if an active 24V signal is required, it can be directly connected to the G and C ports.

Control Logic

Indoor Unit Connector

Connector	Purpose
R	24V Power Connection
C	Common
G	Fan Control
Y1	Low Cooling
Y/Y2	High Cooling
B	Heating Reversing Valve
W	Heating Control
W1	Stage 1 Electric Heating
W2	Stage 2 Electric Heating
E/AUX	Emergency Heating
DH/DS/BK	Dehumidification/Zoning Control
L	System Fault Signal

LED Display

The control displays unit status as well as any active fault codes on the LED display. If the unit is functioning normally, the LED will display the current temperature setpoint. When a fault code is active, the display will quickly flash the active fault code. Refer to the fault code table located in the troubleshooting section of the manual for detailed fault code information.

KEY1 Instructions (For Wired Controller Only)

- Press KEY1 to enter the forced automatic mode. Press KEY1 again to enter the forced cooling mode (LED Display FC). Press KEY1 again to shut down.
- Keep pressing KEY1 under forced cooling mode (LED Display FC) for five seconds to enter forced defrost mode.

8.6 DIP Switch Definitions

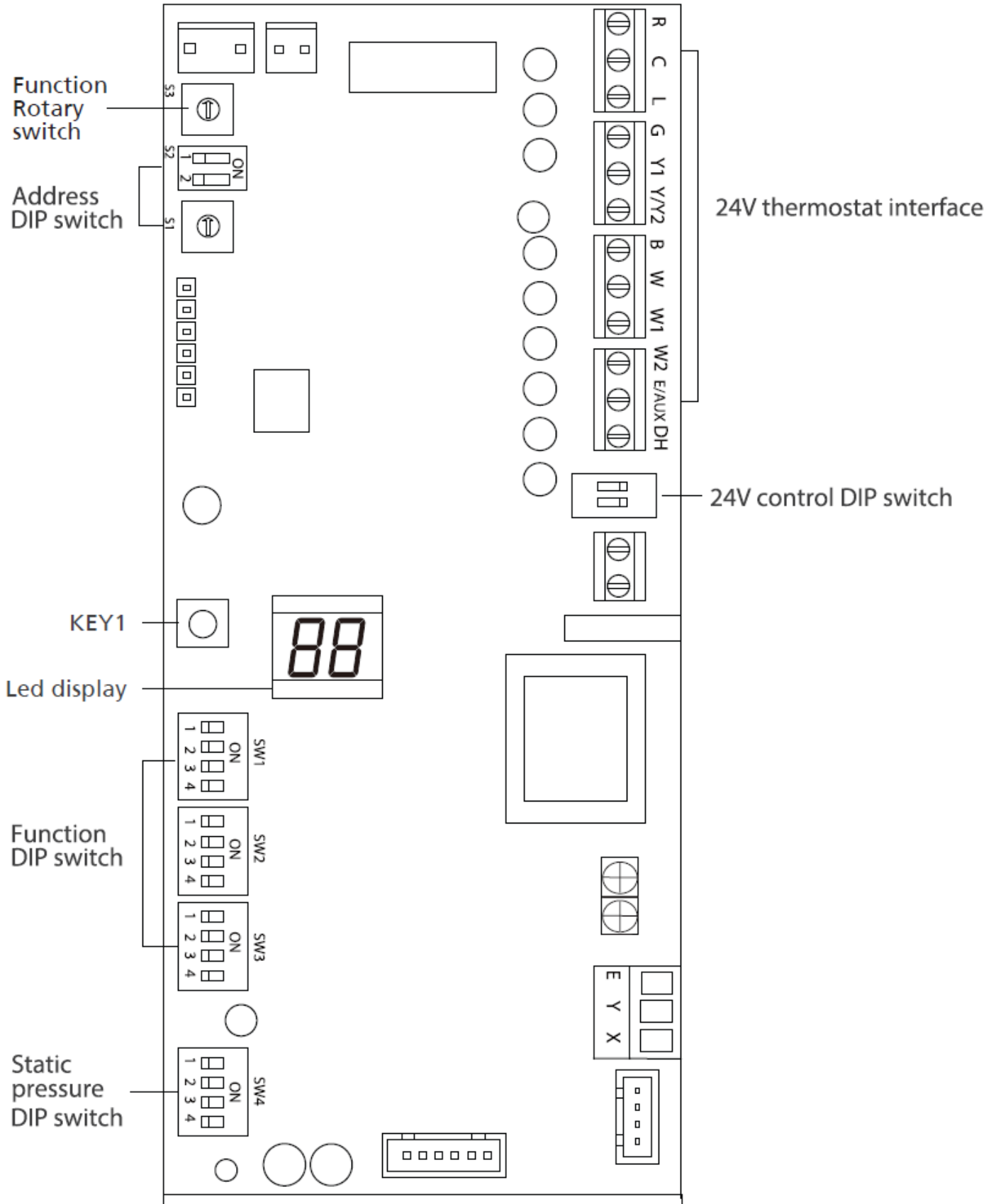

Function DIP Switch Settings:

The 24V thermostat modes must refer to the following settings:

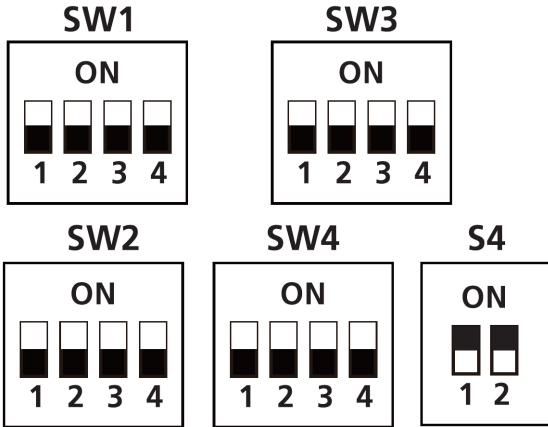

SW4-1	000 is the default 000/001/010/011/100/101/110/111, internal machines with different abilities, electric heating, and PSC classification for use.
SW4-2	
SW4-3	

Function Combination Table of SW1-1 and SW1-4:

SW1	Control type	Stand alone or full system
	Free match	Free match
	Wired controller	Full system
	24V Thermostat	Full system
	24V Thermostat	Stand alone

Indoor Unit Dial Code

No.	Dial Code	Control Scenario	Function	ON	OFF	Note
1	SW1-2	1, 2, 3	Anti-cold blow protection option	NO	[Default] YES	
2	SW1-3	1, 2, 3	Single cooling/heating and cooling options	Cooling	[Default] Cooling & Heating	
3	SW2-1	1	Compressor Running (demand working with heat pump+electric heat)	Compressor slower speed	[Default] Faster Compressor	Only affects compressor and W1
4	SW2-1	2	Temperature differential to activate first stage auxiliary heat (the GAP of T1 and Ts), Wire controller demand with heat pump+electric heat working together	2°F (1°C)	[Default] 4°F (2°C)	
5	SW2-2	2	Electric heat on delay	YES	[Default] NO	
6	SW2-3	2	Electric auxiliary heating delay to start time	30 minutes	[Default] 15 minutes	Based on SW2-2 is ON.
7	SW2-4	1	Compressor	<p>The operation of the heat pump is limited by the outdoor temperature, and the operation of auxiliary heat is not limited. The system makes judgments according to the following rules:</p> <ol style="list-style-type: none"> 1) The compressor can be operated when the outdoor temperature is \geqS3 DIP switch temperature +35.6°F (2°C). 2) The compressor cannot be operated when the outdoor temperature is lower than the S3 DIP switch temperature. 	<p>[Default] The operation of heat pump is limited by the outdoor temperature, and the operation of auxiliary heat is not limited. The system makes judgments based on the following rules:</p> <ol style="list-style-type: none"> 1) The compressor cannot be operated when the outdoor temperature is lower than the S3 DIP switch, 2) The c compressor can be operated when the outdoor temperature is \geqS3 DIP switch temperature +35.6°F (2°C). 	SW2-4 and S3 need to be working together.

8 ELECTRICAL CONNECTIONS

No.	Dial Code	Control Scenario	Function	ON	OFF	Note
8	SW2-4	2	Compressor/Auxiliary heat outdoor ambient lockout	The operation of heat pump is limited by the outdoor temperature, and the operation of auxiliary heat is not limited. The system makes judgments according to the following rules: 1) The compressor can be operated when the outdoor temperature is \geq S3 DIP switch temperature +35.6°F (2°C). 2) The compressor cannot be operated when the outdoor temperature is lower than the S3 DIP switch temperature.	[Default] Only one heat pump or auxiliary heat can be operated. The system makes judgment according to the following rules: 1) When the outdoor temperature is lower than the S3 DIP switch temperature, the compressor is not allowed to operate, but auxiliary heat is allowed to operate. 2) When the outdoor temperature is \geq S3 DIP switch temperature +35.6°F (2°C), the compressor can be operated but auxiliary heat cannot be operated.	SW2-4 and S3 need to be working together.
9	Rotary Switch S3	1, 2	Set outdoor temperature limitation (for auxiliary heating or compressor)	Table A		
10	SW3-1	1	Maximum continuous runtime allowed before system automatically stages up capacity to satisfy set point. This adds 1 to 5°F to the user set point to increase capacity and satisfy user set point.	30 minutes	[Default] 90 minutes	
11	SW3-2	1	Cooling and heating Y/Y2 temperature differential adjustment	Compressor slower speed	[Default] Faster compressor	Only affects compressor
12	SW3-3	1	Compressor running (demand working with heat pump+electric heat)	Compressor slower speed	[Default] Faster compressor	Only affects compressor and W2
13	SW3-3	2	Temperature differential to activate second stage auxiliary heating (the GAP of T1 and Ts). Wire controller demand with heat pump+electric heat working together	4°F (2°C)	[Default] 6°F (3°C)	
14	SW3-4	1, 3	Fan speed of cooling mode when 24V Thermostat is applied for	Turbo	High	
15	SW4	1, 2, 3	Electric heat nominal CFM adjustment	Available settings are 000/001/010/011. Each digit corresponds to an individual switch position. For example [SW4-1 OFF, SW4-2 ON, SW4-3 OFF] = 010; See table 11 for the corresponding CFM adjustment.		
16	S4-1	1, 3	Default ON	[Default] For single stage supplemental heat, W1 and W2 are connected	For dual stage supplemental heat, W1 and W2 are controlled independently.	
17	S4-2	1,3	DH function selection	[Default] Dehumidification control not available	Dehumidification feature is enabled through the thermostat	

Table A

Control Scenario	24V Tstat, S1+S2	1
	Wired Controller S1+S2	2
	Full 24V	3

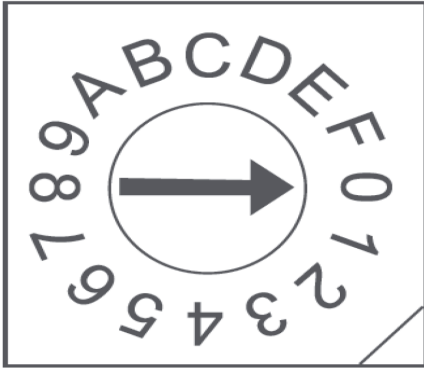

S3	S3 (°F)	S3 (°C)
0	OFF	OFF
1	-22	-30
2	-18	-28
3	-15	-26
4	-11	-24
5	-8	-22
6	-4	-20
7	3	-16
8	10	-12
9	18	-8
A	25	-4
B	32	0
C	36	2
D	39	4
E	43	6
F	46	8

Address DIP Switch:

Address dialing S1+S2: When the user uses the centralized controller, the address dialing is required.

Network address: The address silkscreen is NET address, which is composed of a 16-bit address rotary code S2 plus a two-digit DIP switch S1 [Set during engineering installation, network function does not need to be set]

When S2 is 00 (the dialing code is not connected), the network address value is the value of S2;

When S2 is 10 (corresponding to the switch of the hardware connected to the 10K resistor), the network address value is S2 plus 32;

Determined by dial code S2 1-10K 2-5.1K When S2 is 01 (corresponding to the dial code of the 5.1K resistor connected to the hardware is turned on), the network address value is the value of S2 plus 16;

When S2 is 11 (all dialing codes are on), the network address value is the value of S2 plus 48.

Determined by dial code S2 1-10K 2-5.1K

Dial code selection	Website address
	S2 + 48
	S2 + 32
	S2 + 16
	S2

Air Volume Table

Capacity	External Static Pressure Range	Fan speed	Electric heater kit	24V thermostat		Wired controller		Airflow volume (CFM)
				DIP Switch	24V terminal engaged	DIP Switch	Mode	
18K (1.5 Ton)	0 - 0.80 in. w.g.	Cooling Turbo	—	SW3-4=ON	Y2/Y	—	Cool	618
		Cooling High	—	SW3-4=OFF	Y2/Y	—	Cool	576
		Cooling Medium	—	—	Y1	—	Cool	529
		Cooling Low	—	—	—	—	Cool	488
		Heat Pump Turbo	—	—	—	—	Heat	565
		Heat Pump High	—	—	B+Y2/Y, W	—	Heat	541
		Heat Pump Medium	—	—	Y1	—	Heat	435
		Heat Pump Low	—	—	—	—	Heat	400
		Electric heater kit 0(Default)	10KW	SW4-1=OFF SW4-2=OFF SW4-3=OFF	W1, W2, AUX	SW4-1=OFF SW4-2=OFF SW4-3=OFF	Heat + AUX, AUX	653
		Electric heater kit 1	10KW, 8KW	SW4-1=OFF SW4-2=OFF SW4-3=ON	W1, W2, AUX	SW4-1=OFF SW4-2=OFF SW4-3=ON	Heat + AUX, AUX	624
		Electric heater kit 2	8KW	SW4-1=OFF SW4-2=ON SW4-3=OFF	W1, W2, AUX	SW4-1=OFF SW4-2=ON SW4-3=OFF	Heat + AUX, AUX	594
		Electric heater kit 3	5KW	SW4-1=OFF SW4-2=ON SW4-3=ON	W1, W2, AUX	SW4-1=OFF SW4-2=ON SW4-3=ON	Heat + AUX, AUX	565
24K (2 Ton)	0 - 0.80 in. w.g.	Cooling Turbo	—	SW3-4=ON	Y2/Y	—	Cool	824
		Cooling High	—	SW3-4=OFF	Y2/Y	—	Cool	759
		Cooling Medium	—	—	Y1	—	Cool	694
		Cooling Low	—	—	—	—	Cool	629
		Heat Pump Turbo	—	—	—	—	Heat	788
		Heat Pump High	—	—	B+Y2/Y, W	—	Heat	753
		Heat Pump Medium	—	—	Y1	—	Heat	641
		Heat Pump Low	—	—	—	—	Heat	524
		Electric heater kit 0(Default)	15KW	SW4-1=OFF SW4-2=OFF SW4-3=OFF	W1, W2, AUX	SW4-1=OFF SW4-2=OFF SW4-3=OFF	Heat + AUX, AUX	871
		Electric heater kit 1	15KW, 10KW	SW4-1=OFF SW4-2=OFF SW4-3=ON	W1, W2, AUX	SW4-1=OFF SW4-2=OFF SW4-3=ON	Heat + AUX, AUX	841
		Electric heater kit 2	10KW, 8KW	SW4-1=OFF SW4-2=ON SW4-3=OFF	W1, W2, AUX	SW4-1=OFF SW4-2=ON SW4-3=OFF	Heat + AUX, AUX	818
		Electric heater kit 3	5KW	SW4-1=OFF SW4-2=ON SW4-3=ON	W1, W2, AUX	SW4-1=OFF SW4-2=ON SW4-3=ON	Heat + AUX, AUX	788
30K (2.5 Ton)	0 - 0.80 in. w.g.	Cooling Turbo	—	SW3-4=ON	Y2/Y	—	Cool	988
		Cooling High	—	SW3-4=OFF	Y2/Y	—	Cool	894
		Cooling Medium	—	—	Y1	—	Cool	806
		Cooling Low	—	—	—	—	Cool	712
		Heat Pump Turbo	—	—	—	—	Heat	918
		Heat Pump High	—	—	B+Y2/Y, W	—	Heat	876
		Heat Pump Medium	—	—	Y1	—	Heat	665
		Heat Pump Low	—	—	—	—	Heat	453
		Electric heater kit 0(Default)	15KW	SW4-1=OFF SW4-2=OFF SW4-3=OFF	W1, W2, AUX	SW4-1=OFF SW4-2=OFF SW4-3=OFF	Heat + AUX, AUX	1088
		Electric heater kit 1	15KW, 10KW	SW4-1=OFF SW4-2=OFF SW4-3=ON	W1, W2, AUX	SW4-1=OFF SW4-2=OFF SW4-3=ON	Heat + AUX, AUX	1029
		Electric heater kit 2	10KW, 8KW	SW4-1=OFF SW4-2=ON SW4-3=OFF	W1, W2, AUX	SW4-1=OFF SW4-2=ON SW4-3=OFF	Heat + AUX, AUX	976
		Electric heater kit 3	5KW	SW4-1=OFF SW4-2=ON SW4-3=ON	W1, W2, AUX	SW4-1=OFF SW4-2=ON SW4-3=ON	Heat + AUX, AUX	918

8 ELECTRICAL CONNECTIONS

Air Volume Table

Capacity	External Static Pressure Range	Fan Speed	Electric heater kit	24V thermostat		Wired controller		Airflow volume (CFM)
				DIP Switch	24V terminal engaged	DIP Switch	Mode	
36K (3 Ton)	0 - 0.80 in. w.g.	Cooling Turbo	—	SW3-4=ON	Y2/Y	—	Cool	1188
		Cooling High	—	SW3-4=OFF	Y2/Y	—	Cool	1082
		Cooling Medium	—	—	Y1	—	Cool	971
		Cooling Low	—	—	—	—	Cool	865
		Heat Pump Turbo	—	—	—	—	Heat	1112
		Heat Pump High	—	—	B+Y2/Y, W	—	Heat	1059
		Heat Pump Medium	—	—	Y1	—	Heat	794
		Heat Pump Low	—	—	—	—	Heat	582
		Electric heater kit 0(Default)	20KW	SW4-1=OFF SW4-2=OFF SW4-3=OFF	W1, W2, AUX	SW4-1=OFF SW4-2=OFF SW4-3=OFF	Heat + AUX, AUX	1306
		Electric heater kit 1	15KW	SW4-1=OFF SW4-2=OFF SW4-3=ON	W1, W2, AUX	SW4-1=OFF SW4-2=OFF SW4-3=ON	Heat + AUX, AUX	1241
		Electric heater kit 2	10KW, 8KW	SW4-1=OFF SW4-2=ON SW4-3=OFF	W1, W2, AUX	SW4-1=OFF SW4-2=ON SW4-3=OFF	Heat + AUX, AUX	1176
		Electric heater kit 3	5KW, 8KW	SW4-1=OFF SW4-2=ON SW4-3=ON	W1, W2, AUX	SW4-1=OFF SW4-2=ON SW4-3=ON	Heat + AUX, AUX	1112
		48K (4 Ton)	0 - 0.80 in. w.g.	Cooling Turbo	—	SW3-4=ON	Y2/Y	—
Cooling High	—			SW3-4=OFF	Y2/Y	—	Cool	1282
Cooling Medium	—			—	Y1	—	Cool	1094
Cooling Low	—			—	—	—	Cool	906
Heat Pump Turbo	—			—	—	—	Heat	1471
Heat Pump High	—			—	B+Y2/Y, W	—	Heat	1306
Heat Pump Medium	—			—	Y1	—	Heat	1141
Heat Pump Low	—			—	—	—	Heat	976
Electric heater kit 0(Default)	20KW			SW4-1=OFF SW4-2=OFF SW4-3=OFF	W1, W2, AUX	SW4-1=OFF SW4-2=OFF SW4-3=OFF	Heat + AUX, AUX	1741
Electric heater kit 1	15KW			SW4-1=OFF SW4-2=OFF SW4-3=ON	W1, W2, AUX	SW4-1=OFF SW4-2=OFF SW4-3=ON	Heat + AUX, AUX	1653
Electric heater kit 2	10KW, 8KW			SW4-1=OFF SW4-2=ON SW4-3=OFF	W1, W2, AUX	SW4-1=OFF SW4-2=ON SW4-3=OFF	Heat + AUX, AUX	1559
Electric heater kit 3	8KW			SW4-1=OFF SW4-2=ON SW4-3=ON	W1, W2, AUX	SW4-1=OFF SW4-2=ON SW4-3=ON	Heat + AUX, AUX	1471
60K (5 Ton)	0 - 0.80 in. w.g.			Cooling Turbo	—	SW3-4=ON	Y2/Y	—
		Cooling High	—	SW3-4=OFF	Y2/Y	—	Cool	1582
		Cooling Medium	—	—	Y1	—	Cool	1359
		Cooling Low	—	—	—	—	Cool	1135
		Heat Pump Turbo	—	—	—	—	Heat	1659
		Heat Pump High	—	—	B+Y2/Y, W	—	Heat	1582
		Heat Pump Medium	—	—	Y1	—	Heat	1247
		Heat Pump Low	—	—	—	—	Heat	976
		Electric heater kit 0(Default)	25KW	SW4-1=OFF SW4-2=OFF SW4-3=OFF	W1, W2, AUX	SW4-1=OFF SW4-2=OFF SW4-3=OFF	Heat + AUX, AUX	2171
		Electric heater kit 1	15KW, 20KW	SW4-1=OFF SW4-2=OFF SW4-3=ON	W1, W2, AUX	SW4-1=OFF SW4-2=OFF SW4-3=ON	Heat + AUX, AUX	2029
		Electric heater kit 2	10KW, 15KW	SW4-1=OFF SW4-2=ON SW4-3=OFF	W1, W2, AUX	SW4-1=OFF SW4-2=ON SW4-3=OFF	Heat + AUX, AUX	1894
		Electric heater kit 3	10KW	SW4-1=OFF SW4-2=ON SW4-3=ON	W1, W2, AUX	SW4-1=OFF SW4-2=ON SW4-3=ON	Heat + AUX, AUX	1753

The constant airflow volume motor is applied. Therefore, the airflow volume is constant at all ESP within the stated range.

9-Specifications

Cooling and Heating Power Specifications

MODEL(Btu/h)		18K	24K	30K	
POWER (outdoor)	PHASE	1 Phase			
	FREQUENCY AND VOLT	208/230V,60Hz			
INPUT CIRCUIT FUSE		6.3A	6.3A	6.3A	
LINES GAUGE	OUTDOOR UNIT POWER LINE	LINE QUANTITY	2+Ground		
		LINE DIAMETER(AWG)	14	12	12
	OUTDOOR-INDOOR SIGNAL LINE	LINE QUANTITY	---		
		LINE DIAMETER(AWG)	---		
	THERMOSTAT SIGNAL LINE	LINE QUANTITY	---		
		LINE DIAMETER(AWG)	18		
	INDOOR-OUTDOOR CONNECTION LINE	LINE QUANTITY	4		
		LINE DIAMETER(AWG)	14		

MODEL(Btu/h)		36K	48K	60K	
POWER (outdoor)	PHASE	1 Phase			
	FREQUENCY AND VOLT	208/230V,60Hz			
INPUT CIRCUIT FUSE		16A	16A	16A	
LINES GAUGE	OUTDOOR UNIT POWER LINE	LINE QUANTITY	2+Ground		
		LINE DIAMETER(AWG)	12	10	10
	OUTDOOR-INDOOR SIGNAL LINE	LINE QUANTITY	---		
		LINE DIAMETER(AWG)	---		
	THERMOSTAT SIGNAL LINE	LINE QUANTITY	---		
		LINE DIAMETER(AWG)	18		
	INDOOR-OUTDOOR CONNECTION LINE	LINE QUANTITY	4		
		LINE DIAMETER(AWG)	12		

10 AIR EVACUATION

10.1 Air Evacuation Preparation & Precautions

NOTICE

When opening valve stems, turn the hexagonal wrench until it hits against the stopper. Do not try to force the valve open further.

Air and foreign matter in the refrigerant circuit can cause abnormal rises in pressure, which can damage the unit, reduce its efficiency, and cause injury. Use a vacuum pump and manifold gauge to evacuate the refrigerant circuit, removing any non-condensable gas and moisture from the system. Evacuation should be performed upon initial installation and when unit is relocated.

Before Performing Evacuation:

- ☑ Check to ensure the connective pipes between the indoor and outdoor units are connected properly.
- ☑ Check to make sure all wiring is connected properly.

10.2 Evacuation Instructions

1. Connect the charge hose of the manifold gauge to service port on the outdoor unit's low pressure valve.
2. Connect another charge hose from the manifold gauge to the vacuum pump.
3. Open the low pressure side of the manifold gauge. Keep the high pressure side closed.
4. Turn on the vacuum pump to evacuate the system.
5. Run the vacuum for at least 15 minutes, or until the compound meter reads -76cmHg .

Outdoor Unit

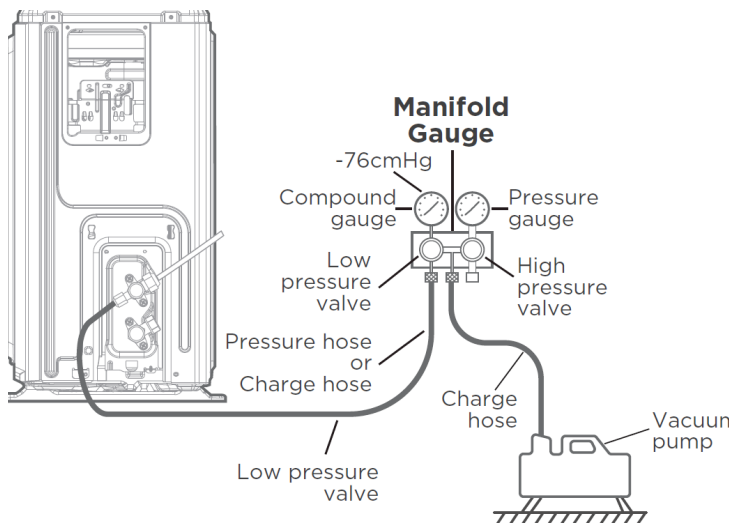

6. Close the low pressure side of the manifold gauge, and turn off the vacuum pump.
7. Wait for 5 minutes, then check that there has been no change in system pressure.
8. If there is a change in system pressure, refer to the Gas Leak Check section for information on how to check for leaks. If there is no change in system pressure, unscrew the cap from the packed valve (high pressure valve).
9. Insert hexagonal wrench into the packed valve (high pressure valve) and open the valve by turning the wrench in a $1/4$ counter clockwise turn. Listen for gas to exit the system, then close the valve after 5 seconds.
10. Watch the pressure gauge for one minute to make sure that there is no change in pressure. The pressure gauge should read slightly higher than atmospheric pressure.
11. Remove the charge hose from the service port.

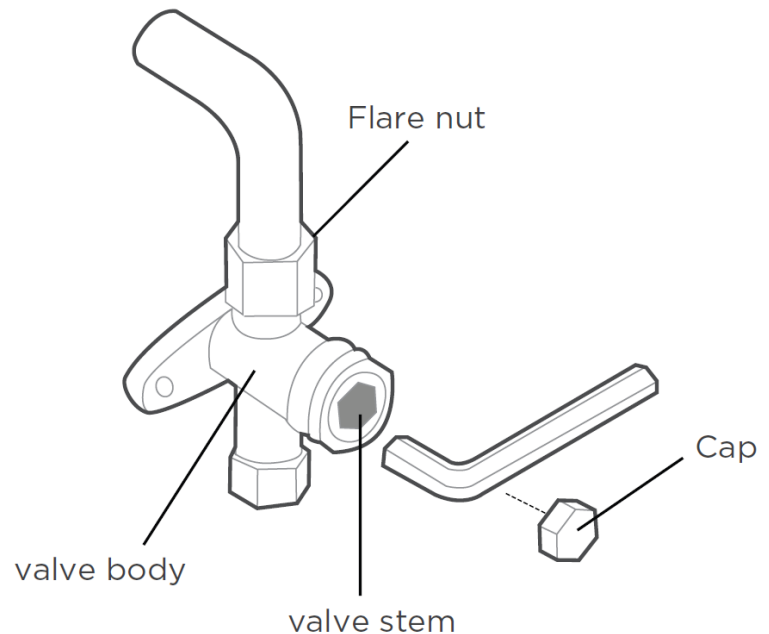

12. Using a hexagonal wrench, fully open both the high pressure and low pressure valves.
13. Tighten valve caps on all three valves (service port, high pressure, and low pressure) by hand. Tighten it further using a torque wrench if needed.

11-Adding Refrigerant

! CAUTION

DO NOT mix refrigerant types.

Some systems require additional charging depending on pipe lengths. The standard pipe length varies according to local regulations. For example, in North America, the standard pipe length is 7.5m (25'). In other areas, the standard pipe length is 5m (16'). The refrigerant should be charged from the service port on the outdoor unit's low pressure valve. The additional refrigerant to be charged can be calculated using the following formula:

	Liquid Side Diameter		
	φ6.35(1/4")	φ9.52(3/8")	φ12.7(1/2")
R410A: (metering device in the indoor unit)	(Total pipe length - standard pipe length) x30g(0.32oZ)/m(ft)	(Total pipe length - standard pipe length) x65g(0.69oZ)/m(ft)	(Total pipe length - standard pipe length) x115g(1.23oZ)/m(ft)
R410A: (metering device in the outdoor unit)	(Total pipe length - standard pipe length) x15g(0.16oZ)/m(ft)	(Total pipe length - standard pipe length) x30g(0.32oZ)/m(ft)	(Total pipe length - standard pipe length) x65g(0.69oZ)/m(ft)

CAUTION

Failure to perform the test run may result in unit damage, property damage, or personal injury.

12.1 Before Test Run

A test run must be performed after the entire system has been completely installed. Confirm the following points before performing the test:

- a) Indoor and outdoor units are properly installed.
- b) Piping and wiring are properly connected.
- c) No obstacles near the inlet and outlet of the unit that might cause poor performance or product malfunction.
- d) Refrigeration system does not leak.
- e) Drainage system is unimpeded and draining to a safe location.
- f) Insulation of piping and duct is properly installed.
- g) Grounding wires are properly connected.
- h) Length of the piping and additional refrigerant capacity have been recorded.
- i) Power voltage is the correct voltage for the system.

12.2 Test Run Instructions

1. Open both the liquid and gas service valves.
2. Turn on the main power switch and allow the unit to warm up.
3. Set the unit to COOL mode.
4. For the Indoor Unit
 - a. Double check to see if the room temperature is being registered correctly.
 - b. Ensure the manual buttons on the indoor unit work properly.
 - c. Check to see that the drainage system is unimpeded and draining smoothly.
 - d. Ensure there is no vibration or abnormal noise during operation.

5. For the Outdoor Unit

- a. Check for any leaks from the refrigeration system.
- b. Make sure there is no vibration or abnormal noise during operation.
- c. Ensure the wind, noise, and water generated by the unit do not disturb individuals nearby or pose a safety hazard.

6. Drainage Test

- a. Ensure the drainpipe flows smoothly. New buildings should perform this test before finishing the ceiling.
- b. Turn on the main power switch and run the unit in COOL mode.
- c. Check to see that the water is discharged. It may take up to one minute before the unit begins to drain depending on the drainpipe.
- d. Make sure that there are no leaks in any of the piping.
- e. Stop the unit. Turn off the main power switch and reinstall the test cover.

NOTICE

If the unit malfunctions or does not operate according to expectations, refer to the Troubleshooting section of the Service Manual before calling customer service.

12.3 24V Signal Chart

Mode	Priority	24V input terminal									Fan speed	Display
		G	Y1	Y/Y2	B	W	W1	W2	E/AUX	DH/DS/BK		
OFF	/	0	0	0	0	0	0	0	0	*	OFF	0
FAN	7	1	0	0	*	0	0	0	0	*	Low	1
Cooling stage 1	6	*	1	0	0	0	0	0	0	1	Mid	2
Cooling stage 2		*	*	1	0	0	0	0	0	1	High	3
Dehumidification		*	1	0	0	0	0	0	0	0	Low	4
Dehumidification		*	*	1	0	0	0	0	0	0	Low	5
Heat pump stage 1	5	*	1	0	1	0	0	0	0	1	Mid	7
Heat pump stage 2		*	*	1	1	0	0	0	0	1	High	
Heat pump stage 2		*	*	*	*	1	0	0	0	1	High	
Electric heater kit 1	3	*	0	0	*	0	1	0	0	*	Turbo	8
Electric heater kit 2		*	0	0	*	0	0	1	0	*	Turbo	
Electric heater kit 1 and kit 2		*	0	0	*	0	1	1	0	*	Turbo	9
Heat pump stage 1 + Electric heater kit 1	4	*	1	0	1	0	1	0	0	1	Turbo	10
Heat pump stage 1 + Electric heater kit 2		*	1	0	1	0	0	1	0	1	Turbo	
Heat pump stage 2 + Electric heater kit 1		*	*	1	1	0	1	0	0	1	Turbo	
Heat pump stage 2 + Electric heater kit 1		*	*	*	*	1	1	0	0	1	Turbo	
Heat pump stage 2 + Electric heater kit 2		*	*	1	1	0	0	1	0	1	Turbo	
Heat pump stage 2 + Electric heater kit 2		*	*	*	*	1	0	1	0	1	Turbo	
Heat pump stage 1 + Electric heater kit 1 and kit 2		*	1	0	1	0	1	1	0	1	Turbo	11
Heat pump stage 2 + Electric heater kit 1 and kit 2		*	*	1	1	0	1	1	0	1	Turbo	
Heat pump stage 2 + Electric heater kit 1 and kit 2		*	*	*	*	1	1	1	0	1	Turbo	
Emergency heat	1	*	*	*	*	*	*	*	1	*	Turbo	12
Heating zone control	2	*	1	0	1	0	*	*	0	0	Low	13
Heating zone control		*	*	1	1	0	*	*	0	0	Low	
Heating zone control		*	*	*	*	1	*	*	0	0	Low	
Heating zone control		*	0	0	*	0	1	0	0	0	Low	
Heating zone control		*	0	0	*	0	0	1	0	0	Low	
Heating zone control		*	0	0	*	0	1	1	0	0	Low	

Note:

1: 24V signal

0: No 24V signal

*: 1 or 0

The AUU will turn off if the 24V input cannot meet the table.



MRCOOL®
COMFORT MADE SIMPLE

Versa Pro Central Ducted 18K-30K

The design and specifications of this product and/or manual are subject to change without prior notice.
Consult with the sales agency or manufacturer for details.