

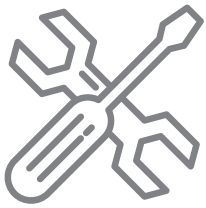

# MRCOOL®

COMFORT MADE SIMPLE



## GeoCool® DC Inverter Geothermal Heat Pump

---

### SERVICE MANUAL

**Version Date: 09/15/23**

**Capacity:** 48kBtu/h 60kBtu/h

**Rate Frequency:** 60Hz

**Operating Range:**

**Cooling:** 44.6°F (7°C) ~107.6°F (42°C)

**Heating:** 21.2°F (-6°C) ~89.6°F (32°C)

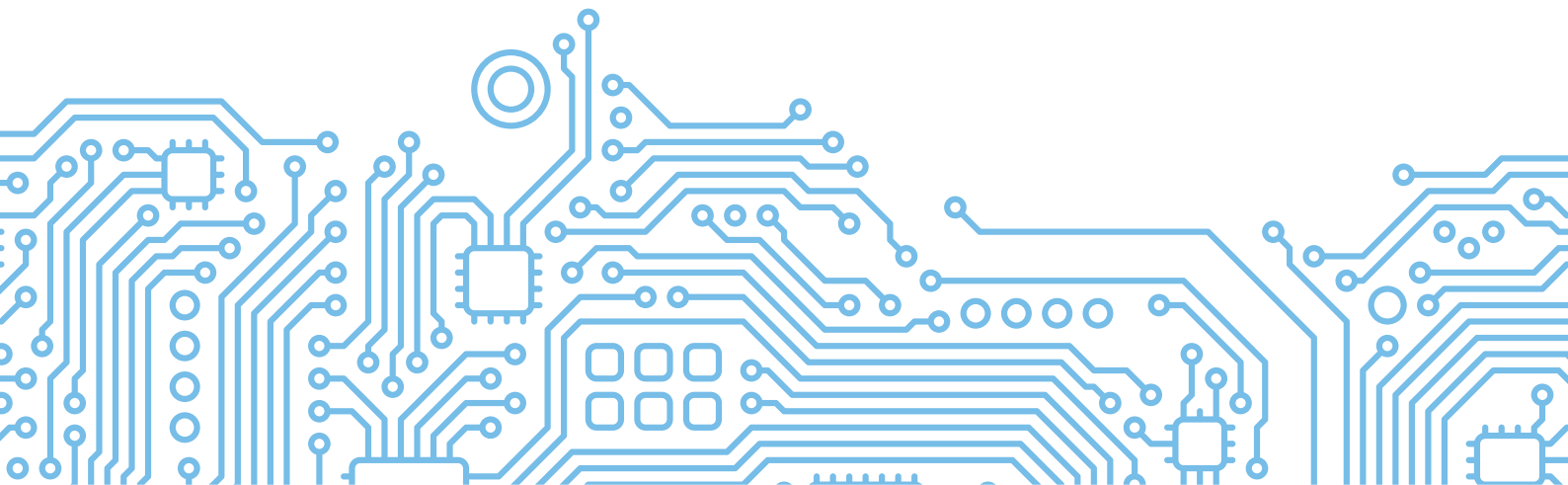



## Foreword

Thank you for choosing this product. In order to correctly install and use our units, and for the satisfactory operation effect, please read this manual carefully.

This manual specifies safe operation requirements from perspectives of product introduction, control, troubleshooting and maintenance, as well as basic principles and implementation methods. Professional operators must abide by relevant national (local) safety requirements and technical specifications set forth in this manual during operations; otherwise, the product system may fail or be damaged, and personnel safety accident may also occur.

## Safety Notice

	Before using this product, please first read the instruction manual.
	Before installing this product, please first read the instruction manual.
	Before repairing this product, please first read the technical service manual.

# CONTENTS

<b>Safety Notice on Maintenance</b> .....	<b>1</b>
<b>Safety Notice on Operation</b> .....	<b>2</b>
<b>1 Product Introduction</b> .....	<b>3</b>
1.1 Lists of Units .....	3
1.2 Electrical Parameters .....	4
<b>2 Control Mode</b> .....	<b>4</b>
2.1 Based Control .....	4
2.2 Special Control .....	5
<b>3 Functions</b> .....	<b>7</b>
3.1 Dip Switch Setting of Compressor Module .....	7
3.2 Dip Switch Setting of A-Coil Module .....	7
3.3 Refrigerant Recovery .....	9
3.4 Water Pump Start-up Function .....	9
<b>4 Power Distribution</b> .....	<b>10</b>
4.1 Diagram of Power Distribution .....	10
4.2 Wiring Diagrams .....	10
4.3 PCB Layout .....	13
4.4 Error Code .....	17
4.4 Troubleshooting .....	18
4.5 Failures Not Caused by Errors .....	44
<b>5 Maintenance</b> .....	<b>46</b>
5.1 System Diagram .....	46
5.2 Connection Pipe Vacuum Pumping .....	46
5.3 Refrigerant Charging .....	48
5.4 Maintenance of Major Components .....	50
5.5 Removal of Major Components .....	58
5.6 Explosive View and Lists of Parts .....	88
<b>5 COMMON PARAMETER LISTS</b> .....	<b>97</b>
5.1 Temperature/Pressure List of Refrigerant .....	97
5.2 Resistance / Temperature Lists of Temperature Sensors .....	98
<b>6 Operation Tools</b> .....	<b>104</b>

## Safety Notice on Maintenance



### PROHIBITED:

- (1) Do not pierce or burn.
- (2) Please note that refrigerant may be odorless.
- (3) The appliance shall be stored in a room without continuously operating ignition sources (For example: open flames, an operating gas appliance or an operating electric heater).
- (4) The installation method is the same with the common joints. However, because the joint can't be detached, if it is badly connected and causes leakage, it needs to be cut and replaced by a new one through welding.
- (5) Using unsuitable parts or tools may lead to electric shock or fire hazard.
- (6) If refrigerant leaks during maintenance, please ventilate the room immediately. Heavy leakage may lead to breathing difficulty, severe injury or death.
- (7) Disconnect power before disassembling the appliance for maintenance.
- (8) The appliance should be maintained and cared by authorized technical personnel with necessary qualifications.



### WARNING:

- (1) If the working place is more than 6.5 ft (2m's) high, please wear a safety helmet, gloves and a safety belt.
- (2) Never mix any other substances except the specified refrigerant into the refrigerant circuit.
- (3) When re-locating the appliance, check whether the new location is strong enough to withstand the weight of the appliance.
- (4) If there is refrigerant leak, please fix the leak before charging in the refrigerant. After refrigerant is charged, check for refrigerant leaks. If you cannot spot the leak, stop the maintenance work. Please evacuate the system and close the service valve to prevent refrigerant leaking into the room.
- (5) Prepare suitable tools and protectors.
- (6) If you need to carry out maintenance or check the electric circuit without cutting off the power, please be careful not to touch the electrical parts.



### NOTICE:

- (1) If the appliance is maintained at a humid place, it should be grounded to avoid electric shock.
- (2) Never repair the unit with wet hands. Operating the unit with wet hands may lead to electric shock.
- (3) If the unit is not correctly grounded, please check and fix it.
- (4) Before cleaning the unit, please disconnect power to prevent the inner fan from starting up and running at high speed; Otherwise personal injury may occur.

- (5) Measure the insulation resistance after maintenance. The resistance must be 3 MΩ or higher. Bad insulation may lead to electric shock.
- (6) Welding and cutting work must be done in a well-ventilated place.
- (7) Gas appliances, heaters and other fire sources should be kept away from the installation and maintenance site.
- (8) Maintenance should be done according to suggestions of the manufacturer.
- (9) Maintenance should be done only after the refrigerant is completely reclaimed from the unit.

**OBSERVED:**

- (1) After the maintenance work is done, check the drainage of A-Coil Module.
- (2) Do not tilt the unit, otherwise, water may spill out from the unit and make the floor and furniture wet.
- (3) Disassembly of the unit, handling of the refrigerant, oil and accessories should all be done according to applicable local rules and regulations.

## Safety Notice on Operation

**PROHIBITED:**

- (1) Never try to modify the unit, otherwise, it may cause electric shock, overheat or fire hazard.
- (2) If the power cord or conducting wires are scratched, please replace them.
- (3) Never use connected or extended power cord or share the power socket with other appliances.
- (4) Prepare a specialized power circuit for the appliance.

**WARNING:**

- (1) If the power plug is dirty, please clean it before inserting it to the power socket. If the power plug is loose, please tight it up.
- (2) Do not damage the power cord. A damaged or refitted power cord may lead to electric shock or fire hazard.
- (3) Check frequently whether the appliance is in good condition.

**NOTICE:**

- (1) Do not use organic solvents to wipe the controller operating panel.
- (2) Before cleaning the unit, cut off the power supply.

# 1 Product Introduction

## 1.1 Lists of Units

### 1.1.1 List of Compressor Module

Model	Power Supply	Cooling/Heating Capacity (Btu/h)	Finished Product Code	Appearance
	V/Ph/Hz			
GCSHPM060IN	208/230V-1Ph-60Hz	62000/55000	ES80100010	
GCSHPM048IN		50500/48000	ES80100020	

### 1.1.2 List of A-Coil Module

Model	Power Supply	Cooling/Heating Capacity (Btu/h)	Finished Product Code	Appearance
	V/Ph/Hz			
GCSCAM060GN	208/230V-1Ph-60Hz	62000/55000	ES82000010	
GCSCAM048GN		50500/48000	ES82000020	

**NOTE:** 1 Ton =12000Btu/h = 3.517kW

### 1.1.3 List of Blower Module

Model	Power Supply	Airflow (CFM)	Finished Product Code	Appearance
	V/Ph/Hz			
GCSBLM014	208/230V-1Ph-60Hz	1400	ES81000010	
GCSBLM013		1400	ES81000020	

## 1.2 Electrical Parameters

Model	Power supply	Fuse Capacity	Circuit breaker capacity
	V/Ph/Hz	A	A
GCSHPM048IN GCSHPM060IN	208/230V-1Ph-60Hz	3.15	35

Model	Power Supply	Fuse Capacity	Circuit Breaker Capacity
	V/Ph/Hz	A	A
GCSCAM048GN GCSCAM060GN	208/230V-1Ph-60Hz	5	15

## 2 Control Mode

### 2.1 Based Control

#### 2.1.1 Compressor Control

When cooling or heating mode is turned on, the fan of Blower module will run for a while before the compressor starts. Under different modes, the compressor can only be stopped after running for some time (special cases excluded). This is to protect the compressor from frequent start or stop. Once the compressor is stopped, it must not be restarted right away. Please wait for a few minutes.

#### 2.1.2 EEV Control

When the unit is first started, the electronic expansion valve will reset control. During the process, the expansion valve will produce rattling sound. When cooling or heating mode is turned on, the valve will be open at a certain step before the compressor starts.

### **2.1.3 4-way Valve Control**

After heating mode is turned on for a while, 4-way valve will be energized to change the direction of refrigerant flow so that the system can run in heating. Under other modes, the valve will not be energized.

To avoid the 4-way valve from incorrectly changing directions, when the unit stops in heating, due to a temperature point or other protection reasons, the 4-way valve will continue to energized temporarily and lose power after a while.

There must be enough pressure difference between the condensing and evaporation pressure for the 4-way valve before changing directions.

## **2.2 Special Control**

### **2.2.1 Oil Return Control**

If the unit is running at low frequency for a long time, oil return control is needed to let the oil in the pipeline back to the compressor. Generally, this control will take 4~6min. The compressor frequency will be raised.

### **2.2.1 High-Pressure Protection**

If the high pressure switch of the unit is detected to trip at 4.2MPa or if the high pressure temperature measured by high pressure sensor exceeds 149°F (65°C) for a period of time, the mainboard display screen will display error code "E1" and the unit will shut down. High-Pressure Protection can be cleared by manually powering off the unit. The reset pressure of the high pressure switch is 3.6MPa.

### **2.2.3 Low Pressure Protection Control**

There are two low pressure switches for the unit. One is for ground water application designed to trip at 0.25MPa (reset at 0.3MPa), the other is for ground-loop application designed to trip at 0.1Mpa (reset at 0.2MPa).

When the low pressure switch is detected to trip for a period of time, the unit will shut down and the mainboard display screen will display error code E3. The unit will restart when the low pressure switch has reset within a few minutes. If low pressure protection occurs for several times in a short time, the unit will not restart automatically. You need to restart the unit manually.



## 2.2.4 High Discharge Temperature Protection

If the discharge temperature of the unit is detected to be higher than 230°F (110°C) for a period of time, the unit shuts down and displays error code "E4" on the main board display screen. When it is detected that the discharge temperature of the unit is less than the 194°F (90°C) for a period of time, the error will be cleared and the unit will restart. If High Discharge Temperature Protection occurs multiple times within a certain period of time, the error cannot be automatically cleared and need to be cleared manually by powering off the unit.

## 2.2.5 Anti-Freezing Protection

Under cooling mode, if the temperature of the evaporator (measured by the in-tube temperature sensor) is detected to be lower than the limit value for a continuous period of time, the evaporator is at risk of frosting, the unit will enter Anti-Freezing Protection and shut down. If the temperature of the evaporator is detected to be higher than the relating value for a period of time, the unit will restart. If the anti-freezing protection occurs multiple times during a period of time in the cooling mode, the unit will stop and the error code "E2" will be displayed on the main board display screen and the error need to be cleared by manually powering off the unit.



For ground water application, if the compressor is not operating and the inlet or outlet water temperature of the Compressor module is below 33.8°F (1°C), water valve will open and the water pump will start to circulate the water in the water loop. The error code "E2" will display on the main board display screen. If the water temperature is higher than 41°F (5°C) for a period of time, the anti-freezing protection will be cleared. The water pump will shut down and water valve will close.

## 3 Functions

### 3.1 Dip Switch Setting of Compressor Module

#### 3.1.1 Geothermal Mode Setting

The geothermal application of the unit can be set through the second dip switch SA2 on the mainboard of the Compressor module. The specific definitions of the dip switch are as follows.

Model	Geothermal Application	Dip switches of Compressor Module
GCSHPM048IN	Ground Water (Default)	
GCSHPM060IN	Ground Loop	

### 3.2 Dip Switch Setting of A-Coil Module

#### 3.2.1 Fan Speed Setting

Set the fan speed through the dip switch SA1 of the A-Coil Module mainboard and you can change the fan speed by the first dip switch of the SA1. For the automatic adjustment control, the fan speed will change according to the temperature of return air temperature. For fixed speed control, the fan will run at a certain level.

The specific definition of the dip switch is as follows.

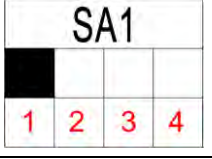
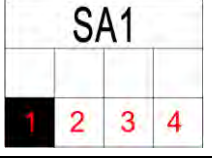
Model	DIP Switch	Speed Control	Dip switches of A-Coil Module
GCSCAM048GN	The first dip switch of the SA1	Automatic Adjustment Control	
GCSCAM060GN		Fixed Speed Control	

Model	Dip Switch	Fan Speed	Dip switches of A-Coil Module
GCSCAM048GN GCSCAM060GN	SA1	Level 1	
		Level 2	
		Level 3 (Default)	
		Level 4	
		Level 5	

### 3.2.2 Supply Air Direction Setting

The supply air direction of the unit need to be set through the second dip switch of SA2 on the mainboard of the A-Coil module according to the installation of the unit. The specific definition of the dip switch is as follows.

Model	Air flow directions	Dip switches of A-Coil Module
GCSCAM048GN GCSCAM060GN	Vertical Upflow/ Horizontal Return Air (Default)	
GCSCAM060GN	Vertical Downflow	

**NOTE:**

- ① During installation and debugging, pay attention to check whether the thermostat has set the fan delay and shutdown time. The actual delay and shutdown time of the fan depends on the setting of the thermostat.

### 3.3 Refrigerant Recovery

This function is part of the debugging function. It is only used for the situation that the unit would be removed to another place and the refrigerant need to be recovered to the unit from the pipelines.

When the unit is shut down, the debugging function can be enabled by the operation of SW1-3.

1. Press and hold "SW1" for about 5 seconds to enter the first level menu of debug menu.
2. Under the first level menu, press and hold "SW1" for about 5 seconds to switch to the number "08".
3. Press and hold "SW2" or "SW3" for about 5 seconds to enter the control mode. "ON" means on, and "OF" means off.
4. Press and hold "SW1" for about 5 seconds to save.

Notes: When operating by pressing SW1~3, please maintain the button operation until the display screen changes. During debugging function, if no operation is performed within 10s, the debug menu interface will exit.

### 3.4 Water Pump Start-up Function

This function is part of the debugging function. It is used for evacuating the air from the water pipeline for the installation or maintenance of the water system. The water pump start-up function needs to be operated when the unit is powered on, and must be operated by a professional. The water or antifreeze solution need to be added at the same time.

When the unit is shut down, the debugging function can be enabled by the operation of SW1-3.

1. Press and hold "SW1" for about 5 seconds to enter the first-level menu of the debugging mode.
2. In the first-level menu, press and hold "SW1" for about 5 seconds to switch to the number "03".
3. Press and hold "SW2" or "SW3" for about 5 seconds to enter the control mode, "ON" means open, "OF" means off.
4. Press and hold "SW1" for about 5 seconds to save.

Notes: When operating by pressing SW1~3, please keep pressing the keys until the display changes.

In this mode, the Water Flow Switch Protection is set to be reserved.

If no air discharges from the discharge valve in the water system, the air can be regarded as fully evacuation.

During debugging function, if no operation is performed within 10s, the debug menu interface will exit.

The limit time of this function is 30min. It will automatically exit and shut down the water pump.

## 4 Power Distribution

### 4.1 Diagram of Power Distribution

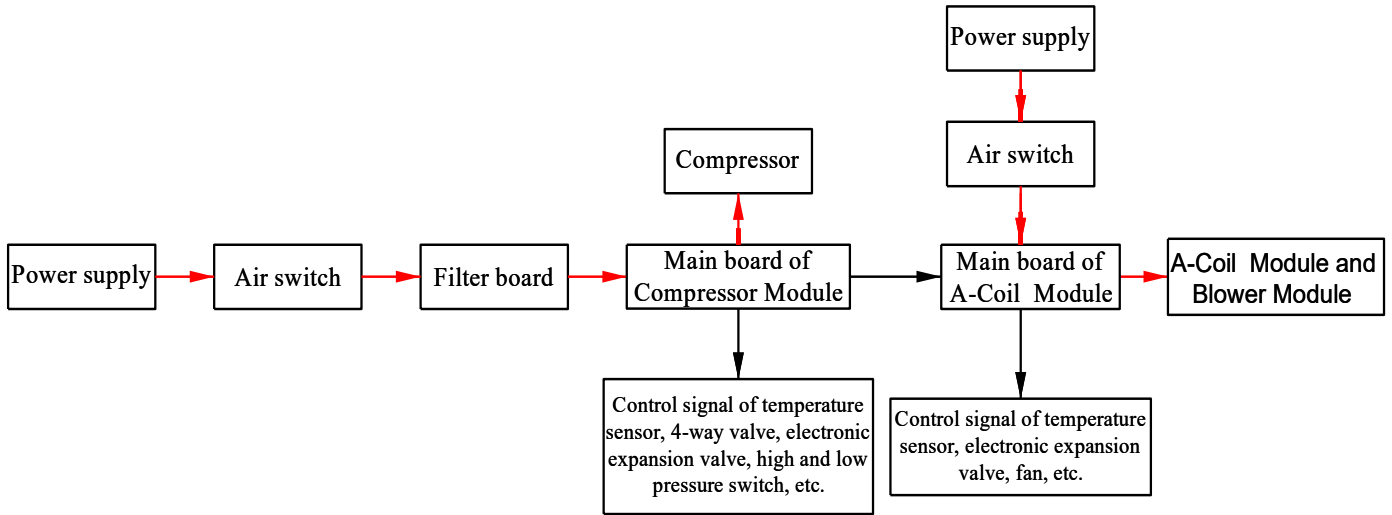

(The red line represents power line while black line represents the control line.)

### 4.2 Wiring Diagrams

The following electric diagram is for reference only. Please refer to diagram stuck on the unit as the latest version.

#### 4.2.1 Wiring Diagrams of Compressor Module

**Model:** GCSHPM048IN / GCSHPM060IN

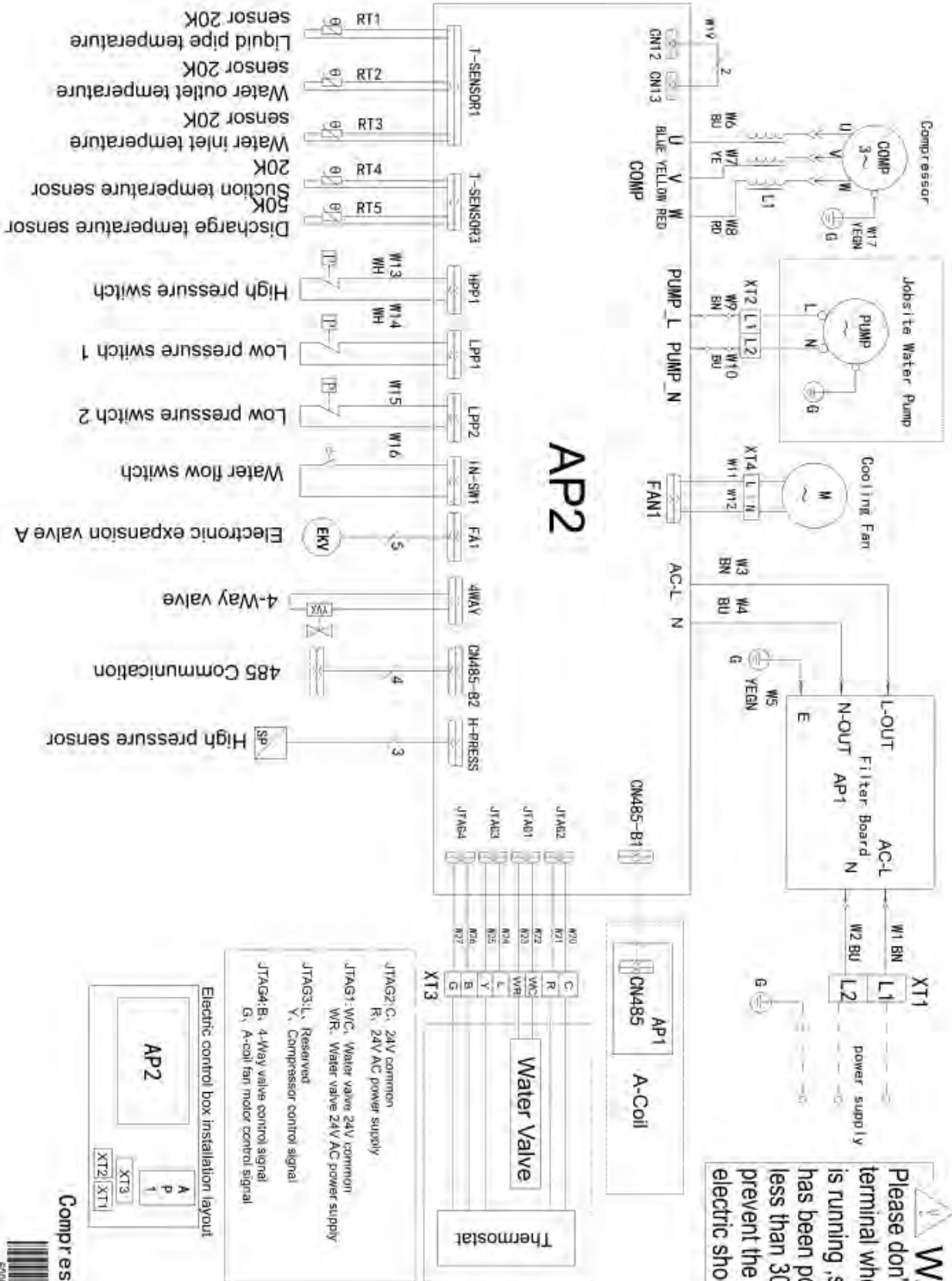

### 4.2.2 Wiring Diagrams of A-Coil Module

Model: GCSCAM048GN / GCSCAM060GN

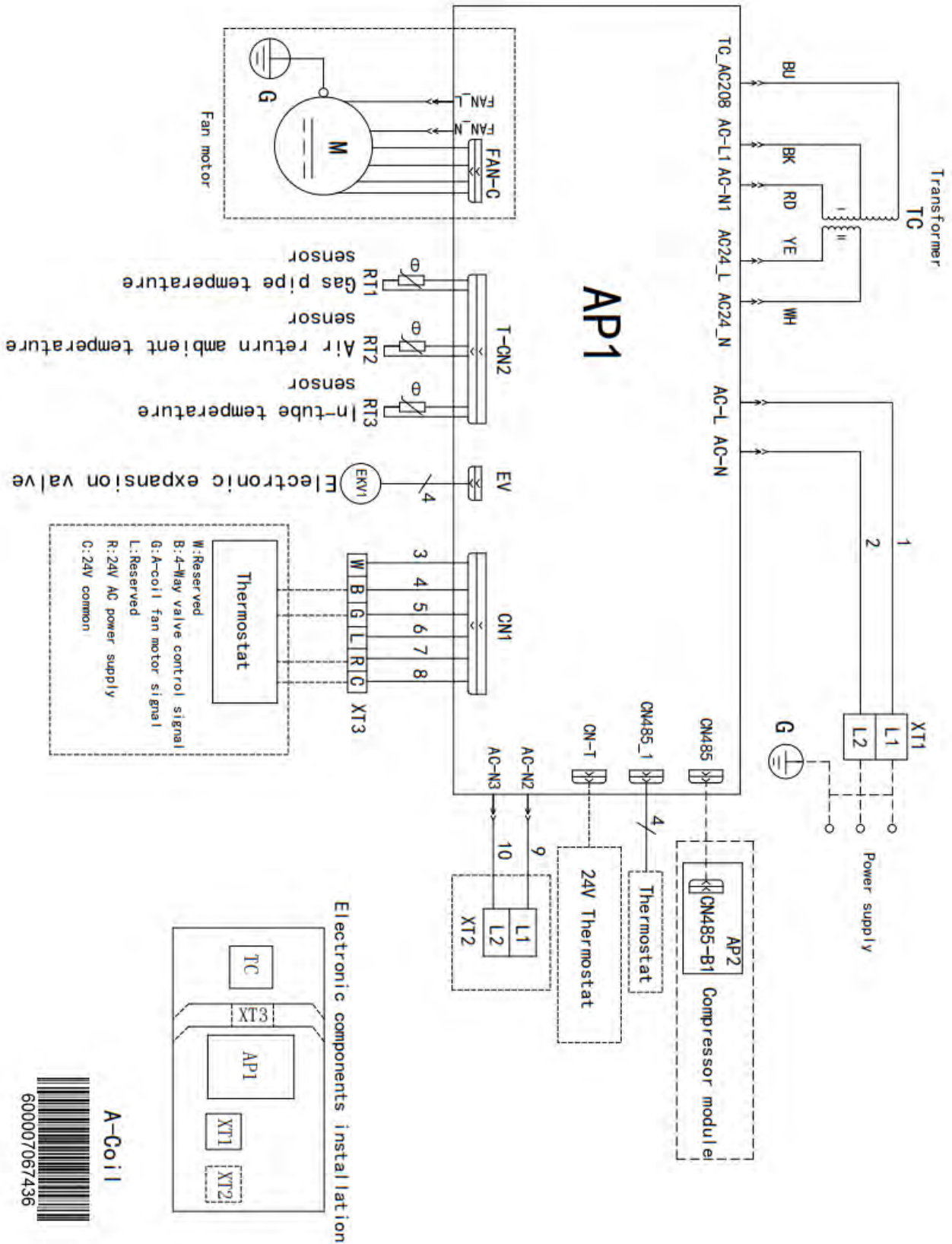

### 4.3 PCB Layout

#### 4.3.1 Interface

A-Coil Module:

**Model:** GCSCAM048GN / GCSCAM060GN

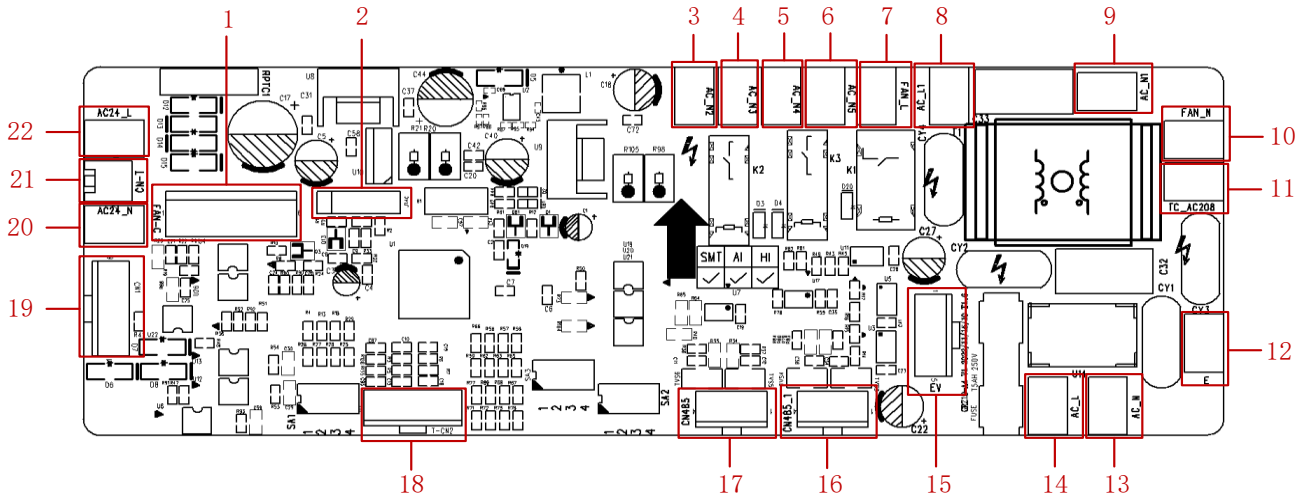

Mainboard

No.	Printing	Terminal	No.	Printing	Terminal
1	FAN_C	Motor control signal terminal	12	E	Ground wire terminal
2	JTAG	Program terminal	13	AC_N	Neutral wire input
3	AC_N2	Reserved	14	AC_L	Live wire input
4	AC_N3	Reserved	15	EV	Electronic expansion valve terminal
5	AC_N4	Reserved	16	CN485_1	485 Wired control communication interface(Reserved)
6	AC_N5	Reserved	17	CN485	485 Wired control communication interface
7	FAN_L	Motor live wire input	18	T-CN2	Thermal pack interface
8	AC_L1	Transformer live wire input (230V)	19	CN1	Thermostat control signal terminal
9	AC_N1	Transformer neutral wire input	20	AC24_N	Transformer neutral wire output
10	FAN_N	Motor neutral wire input	21	CN-T	AC 24V
11	TC_AC208	Transformer live wire input (208V)	22	AC24_L	Transformer live wire output



Compressor Module:

**Model:** GCSHPM048IN / GCSHPM060IN

Mainboard

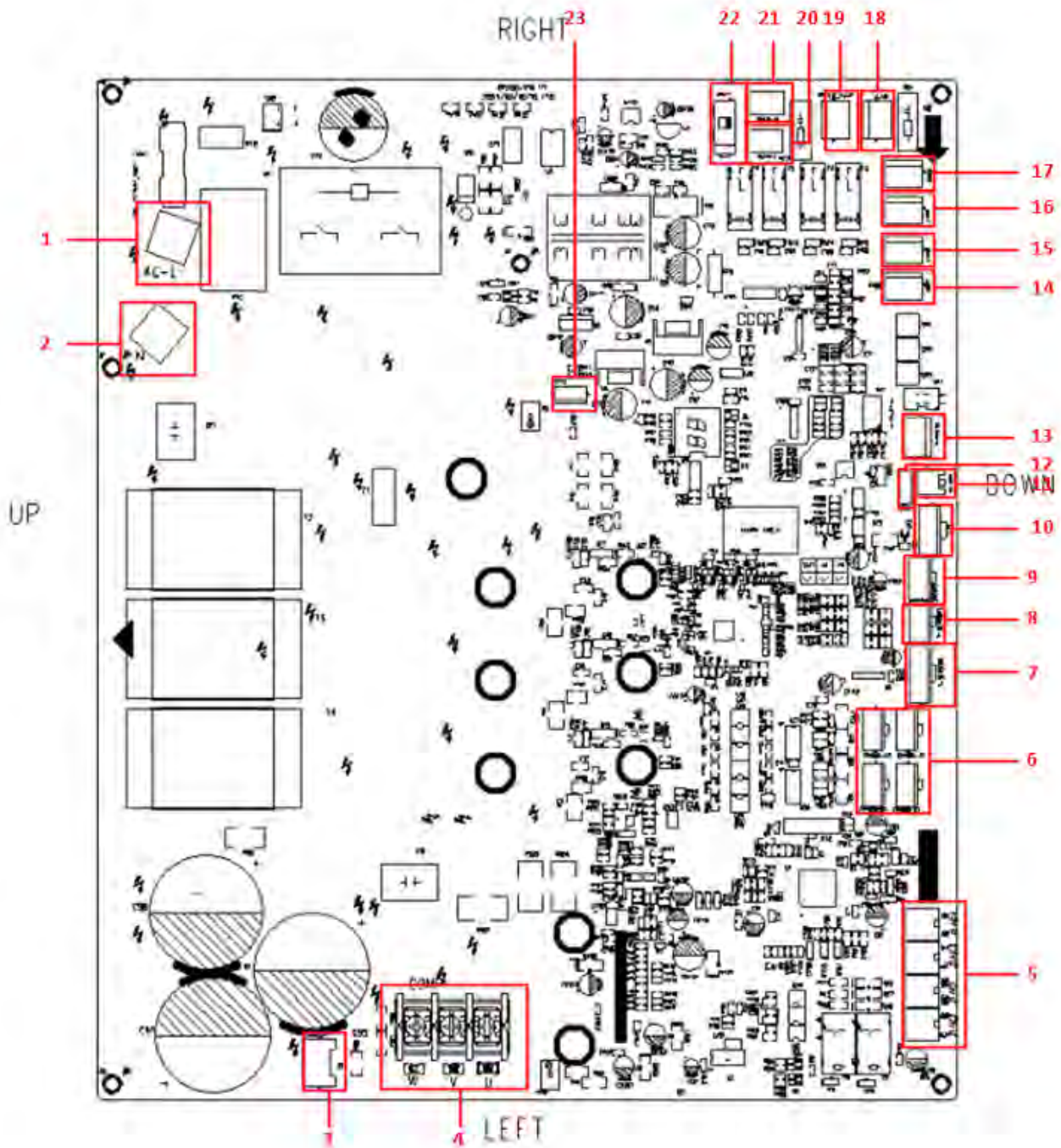

No.	Printing	Terminal	No.	Printing	Terminal
1	AC-L	Live wire input	2	AC-N	Neutral wire input
3	J3	Reserved	4	COMP	Compressor output
5	JTAG2 JTAG1 JTAG3 JTAG4	Wiring terminal	6	CN485-A1 CN485-A2 CN485-B1 CN485-B2	RS485 communication terminal
7	T-SENSOR1	1-2. Water inlet temperature sensor	8	T_SENSOR3	1-2. Suction temperature sensor

No.	Printing	Terminal	No.	Printing	Terminal
		terminal 3-4. Water outlet temperature sensor terminal 5-6. Liquid pipe temperature sensor terminal			terminal 3-4. Discharge temperature sensor terminal
9	T_SENSOR2	Reserved	10	FA1	Electronic expansion valve terminal
11	IN-SW1	Water flow switch	12	CN12	5V DC power supply input
13	H-PRESS	High pressure sensor terminal	14	HPP2	System high pressure protection terminal
15	LPP2	System low pressure protection terminal	16	LPP1	System low pressure protection terminal
17	HPP2	System high pressure protection terminal	18	FAN1	Fan terminal
19	WATER_PUMP	Reserved	20	PUMP-L	Water pump live wire input
21	PUMP-N	Water pump neutral wire input	22	4WAY	4-way valve
23	CN13	5V DC power supply output			

Filtering Board:

**Model:** GCSHPM048IN / GCSHPM060IN

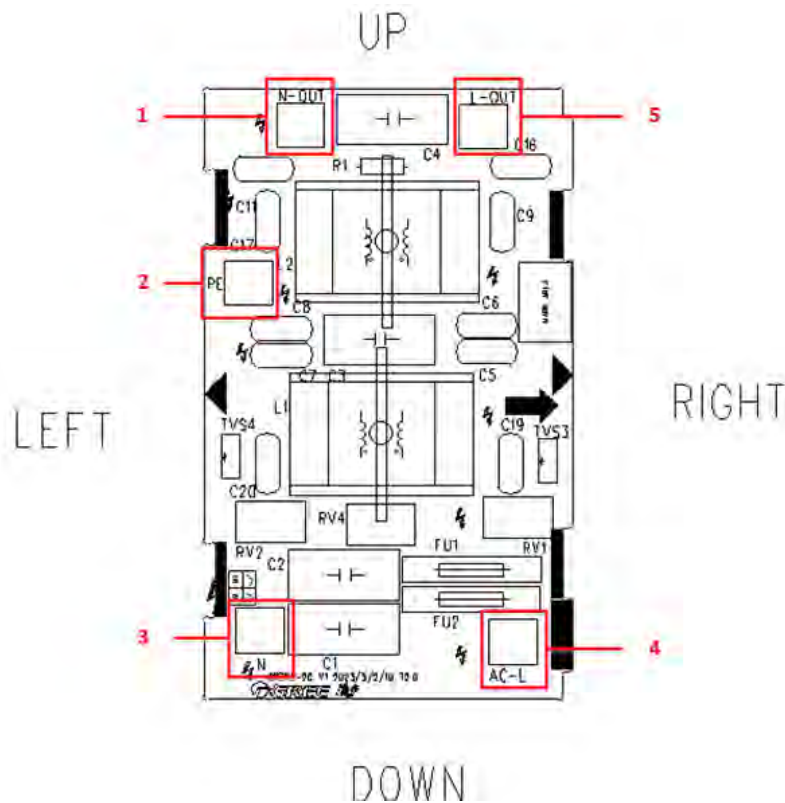

No.	Printing	Terminal	No.	Printing	Terminal
1	N-OUT	Power output neutral wire terminal	2	PE	Filtering board ground wire terminal
3	N	Power input neutral wire terminal	4	AC-L	Power input live wire terminal
5	L-OUT	Power output live wire terminal			

## 4.3.2 IPM, PFC Testing Method

### 4.3.2.1 Method of Testing IPM Module

(1) Preparation before test: prepare a universal meter and turn to its diode option, and then remove the wires U, V, W of the compressor after it is powered off for one minute.

(2) Testing Step

Step 1: put the black probe on the place P and the red one on the wiring terminal U, V, W respectively as shown in the following figure to measure the voltage between UP, VP and WP.

Step 2: put the red probe on the place GND and the black one on the wiring terminal U, V, W respectively as shown in the following figure to measure the voltage between NU, NV and NW.

(3) If the measured voltages between UP, VP, WP, NU, NV, NV are all among 0.3V-0.7V, then it indicates the IPM module is normal; If any measured value is 0, it indicates the IPM is damaged.

### 3.3.2.2 Method of Testing PFC Module Short Circuit

(1) Preparation before testing: Prepare a multimeter, then turn it on to the DC voltage mode. After powering off for 20 minutes, remove the AC-L and N wires.

(2) Connect the red probe of the multimeter to P and the black probe to GND, confirm that the voltage is less than 10V, and then turn the multimeter on to the diode position.

(3) Place the black probe at point P, and the red probe at points D8-2, D5-2, and D2-2, respectively. Then measure the voltage between D8-2, D5-2, and D2-2 to P. If the voltage between D8-2 and P, D5-2 and P, D2-2 and P is between 0.3 and 0.7V, it indicates that diodes D8, D5, and D2 in the PFC circuit are normal. If the measured value is 0, the PFC circuit is damaged.

(4) Place the red probe at the GND point and the black probe at Q9-2, Q10-2, and Q11-2, respectively, to measure the voltage between GND point and Q9-2, Q10-2, and Q11-2. If the voltage value between GND point and Q9-2, Q10-2, and Q11-2 is between 0.3 and 0.7V, it indicates that the MOS tubes Q9, Q10, and Q11 in the PFC circuit are normal. If the measured value is 0, the PFC circuit is damaged.

GCSHPM048IN / GCSHPM060IN

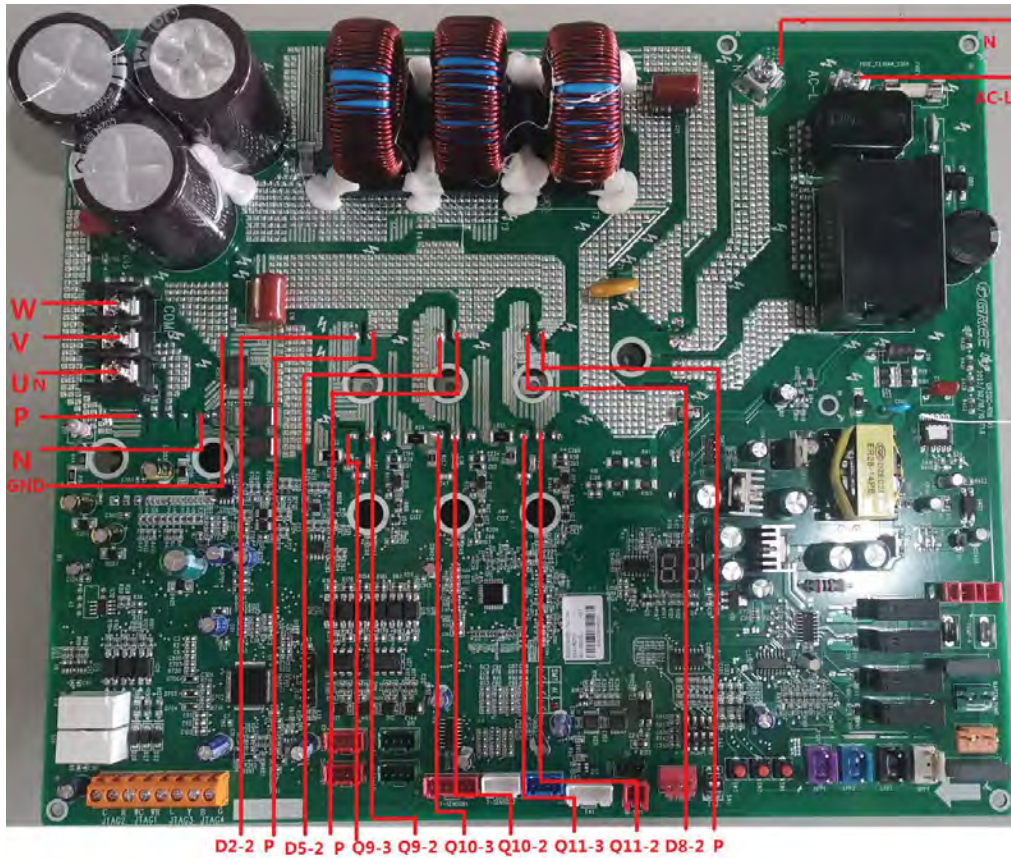

### 4.4 Error Code

If error occurs during operation, LCD temperature display screen will show the error information. If several errors occur at the same time, their corresponding error codes will be shown in turn. When error occurs, please shut off the unit and send for professional personnel to repair. For example, E1 (as shown below) indicates high pressure protection.

No.	Error code	Error
1	E1	High-Pressure Protection
2	E2	Anti-Freezing Protection
3	E3	Low-Pressure Protection
4	E4	High Discharge Temperature Protection
5	EC	Water Flow Switch Protection
6	C6	Discharge Temperature Sensor Error
7	dc	Suction Temperature Sensor Error
8	FB	Water Inlet Temperature Sensor Error
9	FM	Water Outlet temperature Sensor Error
10	A7	Liquid Pipe Temperature Sensor Error
11	E0	Fan Error



No.	Error code	Error
12	C2	In-Tube Temperature Sensor Error
13	Cb	Gas Pipe Temperature Sensor Error
14	C1	Return Air Temperature Sensor Error
15	E6	Communication Error
16	LF	Power Protection
17	E5	Current Protection
18	H5	IPM Protection
19	HC	PFC Protection
20	P8	High Driver Module Temperature Protection
21	PL	DC Bus Under-Voltage Protection or DC Bus Voltage Drop Error
22	PH	DC Bus Over-Voltage Protection
23	PU	Charging Circuit Error
24	C9	Chip Error
25	H3	High-Pressure Sensor Error
26	LP	Capacity DIP Switch Setting Error

## 4.4 Troubleshooting

### 4.4.1 “E1” High-Pressure Protection

**Error display:** Compressor Module mainboard LED display screen

**Error judgment condition and method:**

If the high pressure switch of the unit is detected to trip at 4.2MPa or if the high pressure temperature measured by high pressure sensor exceeds 65°C for a period of time, the mainboard display screen will display error code "E1" and the unit will shut down. High-Pressure Protection can be cleared by manually powering off the unit. The reset pressure of the high pressure switch is 3.6MPa.

**Possible reason:**

- Cut-off valve of Compressor module or A-Coil module is not fully opened;
- High-pressure switch or high pressure sensor is abnormal;
- Fan of Blower module is not working properly;
- Filter or air duct is blocked (heating mode);
- Refrigerant charging amount is too much;
- System pipeline is blocked

**Troubleshooting:**

Heating Mode:

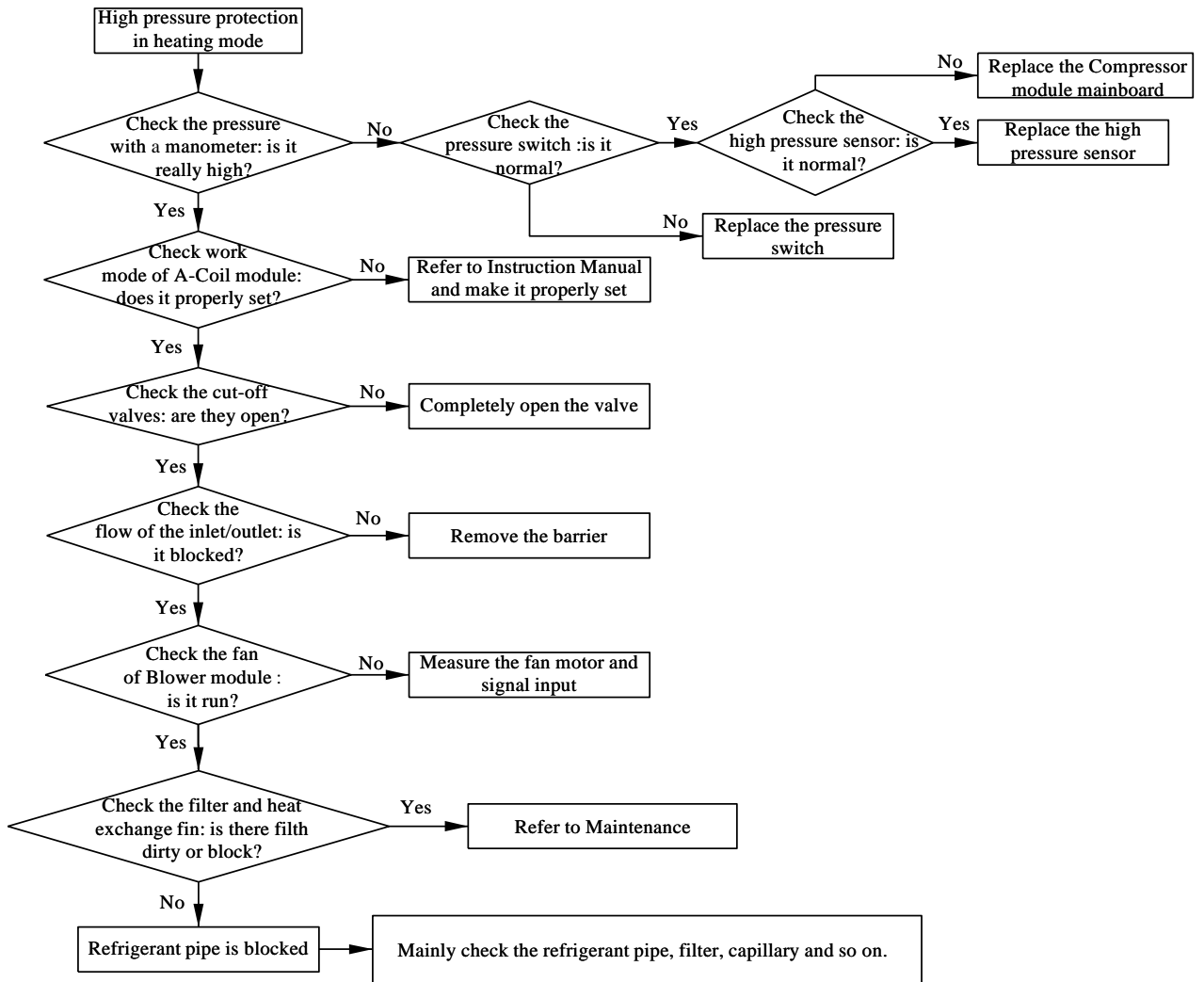

Cooling Mode:

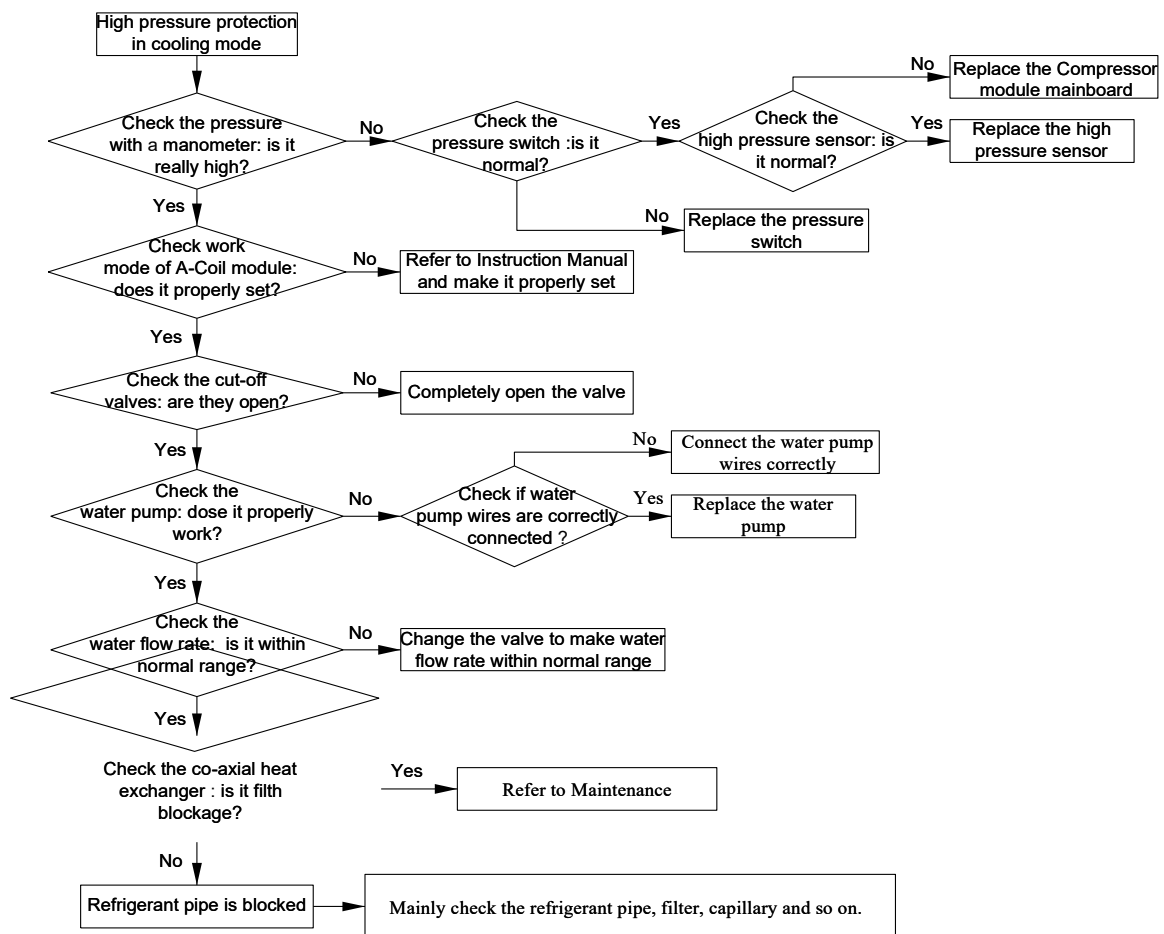

#### 4.4.2 “E2” Anti-Freeze Protection

**Error display:** Compressor Module mainboard LED display screen

**Error judgment condition and method:**

Under cooling mode, if the temperature of the evaporator (measured by the in-tube temperature sensor) is detected to be lower than the limit value for a continuous period of time, the evaporator is at risk of frosting, the unit will enter Anti-Freezing Protection and shut down. If the temperature of the evaporator is detected to be higher than the relating value for a period of time, the unit will restart. If the anti-freezing protection occurs multiple times during a period of time in the cooling mode, the unit will stop and the error code "E2" will be displayed on the main board display screen and the error need to be cleared by manually powering off the unit.

For ground water application, if the compressor is not operating and the inlet or outlet water temperature of the Compressor module is below 33.8°F (1°C), water valve will open and the water pump will start to circulate the water in the water loop. The error code "E2" will display on the main board display screen. If the water temperature is higher than 41°F (5°C) for a period of time, the anti-freezing protection will be cleared. The water pump will shut down and water valve will close.

**Possible reason:**

- Water inlet temperature is too low;
- Fan of Blower module is not working properly;

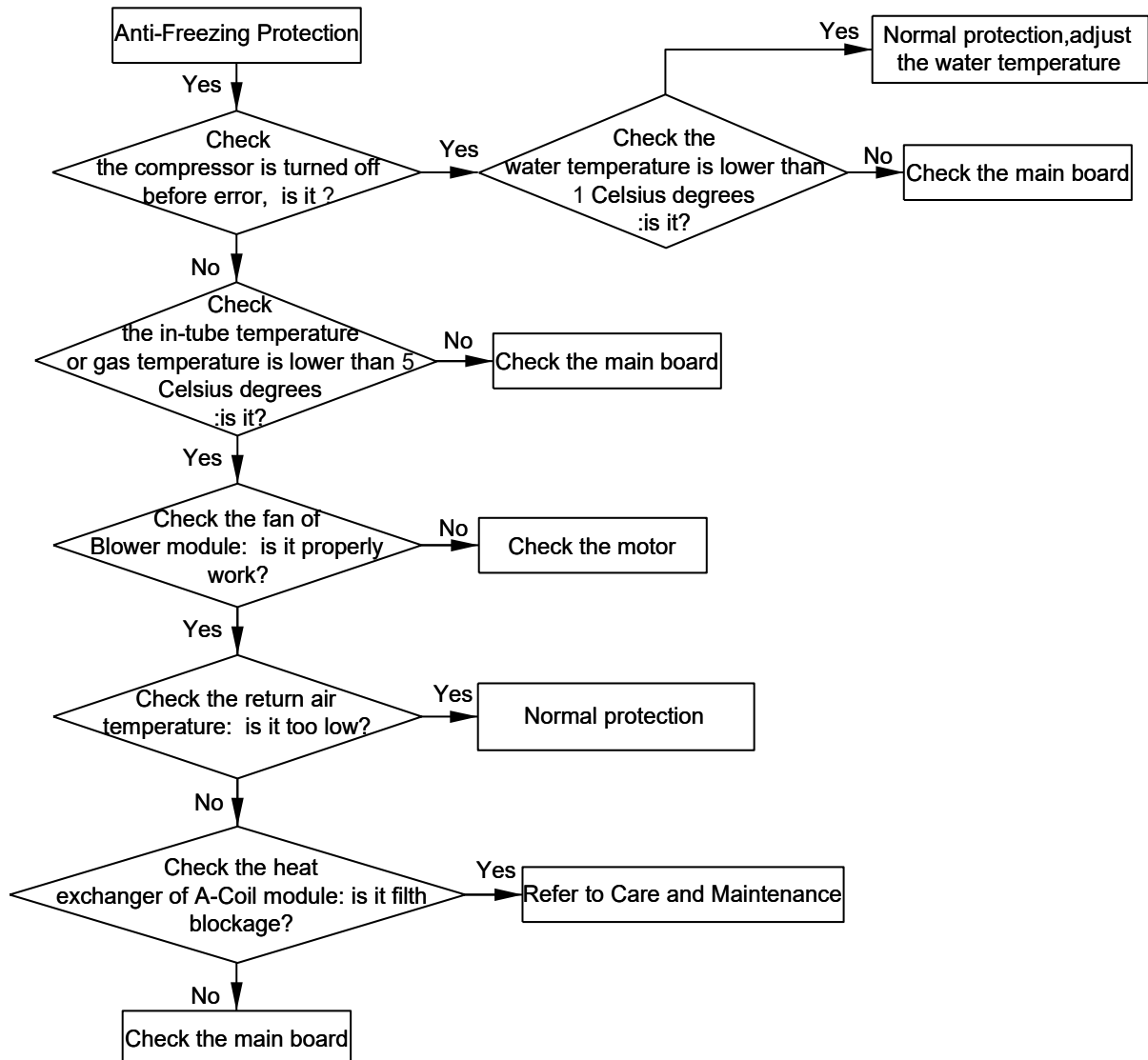
**Troubleshooting:****4.4.3 “E3” Low-Pressure Protection**

**Error display:** Compressor Module mainboard LED display screen

**Error judgment condition and method:**

There are two low pressure switches for the unit. One is for ground water application designed to trip at 0.25MPa (reset at 0.3MPa), the other is for ground-loop application designed to trip at 0.1Mpa (reset at 0.2MPa).

When the low pressure switch is detected to trip for a period of time, the unit will shut down and the mainboard display screen will display error code E3. The unit will restart when the low pressure switch has reset within a few minutes. If low pressure protection occurs for several times in a short time, the unit will not restart automatically. You need to restart the unit manually.



**Possible reason:**

- Cut-off valve of Compressor module or A-Coil module is not fully opened;
- Dip switch of geothermal application on compressor module mainboard is wrong;
- Low-pressure switch is abnormal;
- Fan of Blower module is not working properly;
- Filter or air duct is blocked (cooling mode);
- Refrigerant charging amount is insufficient;
- System pipeline is blocked;
- Refrigerant leakage

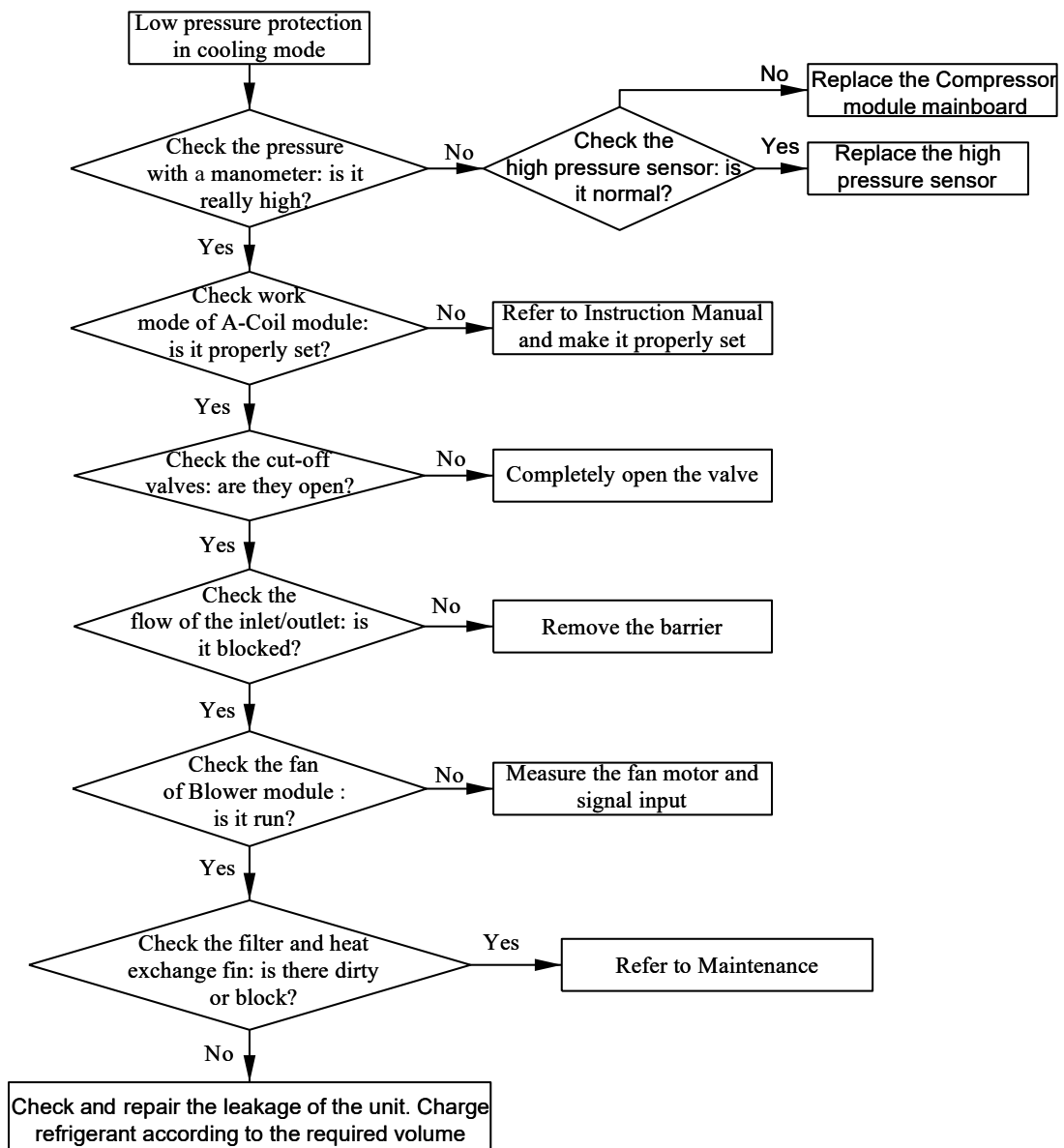
**Troubleshooting:****Cooling Mode**

Heating Mode

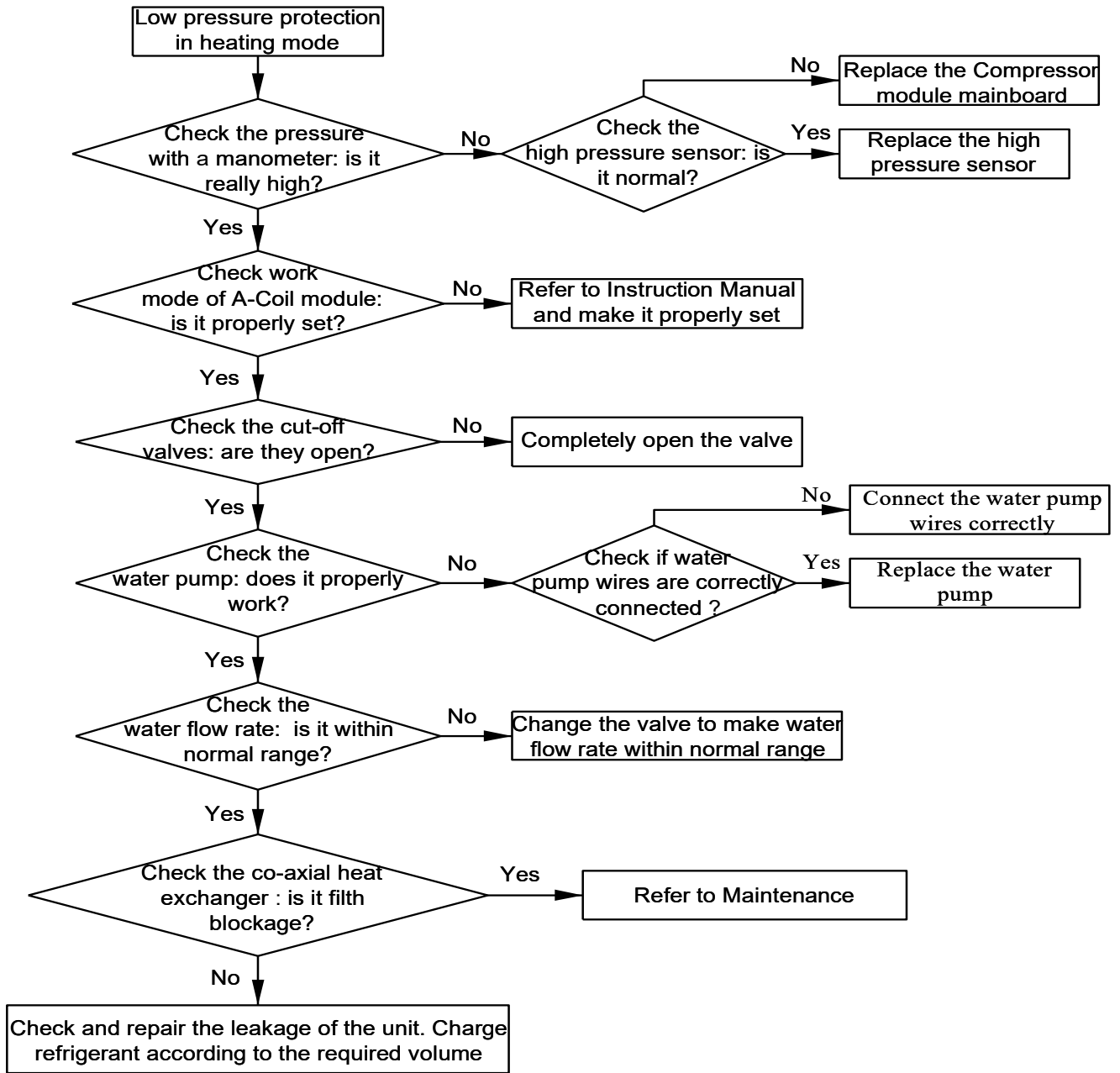

#### 4.4.4 “E4” High Discharge Temperature Protection

**Error display:** Compressor Module mainboard LED display screen

**Error judgment condition and method:**

If the discharge temperature of the unit is detected to be higher than 230°F (110°C) for a period of time, the unit shuts down and displays error code "E4" on the main board display screen. When it is detected that the discharge temperature of the unit is less than the 194°F (90°C) for a period of time, the error will be cleared and the unit will restart. If High Discharge Temperature Protection occurs multiple times within a certain period of time, the error cannot be automatically cleared and need to be cleared manually by powering off the unit.

**Possible reason:**

- Cut-off valve of Compressor module or A-Coil module is not fully opened;
- Electronic expansion valve is abnormal;
- Fan of Blower module is not working properly;
- Refrigerant charging amount is insufficient;
- System pipeline is blocked;
- Refrigerant leakage

**Troubleshooting:**

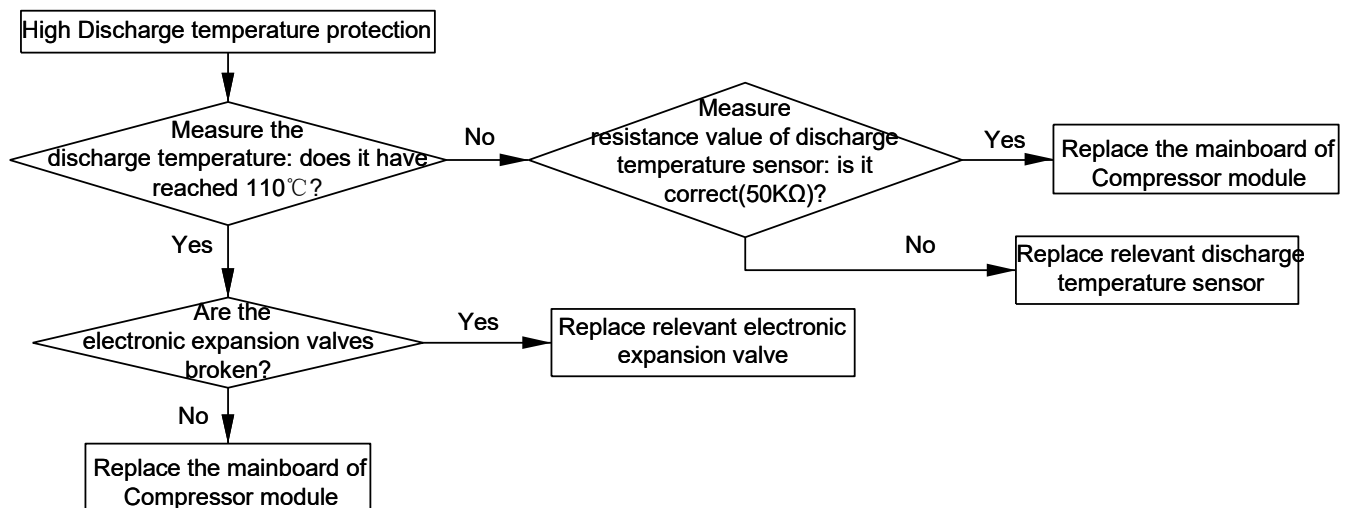

#### 4.4.5 “EC” Water Flow Switch Protection

**Error display:** Compressor Module mainboard LED display screen

**Error judgment condition and method:**

If the water flow switch is detected for a continuous period of time, the system will enter Water Flow Switch Protection. The error code "EC" will be displayed on the main board display screen, and the unit shuts down. The error cannot be automatically cleared and can only be cleared through manual power off.

**Possible reason:**

- Insufficient water flow in the system
- Water flow switch signal line loosening
- Water flow switch target failure

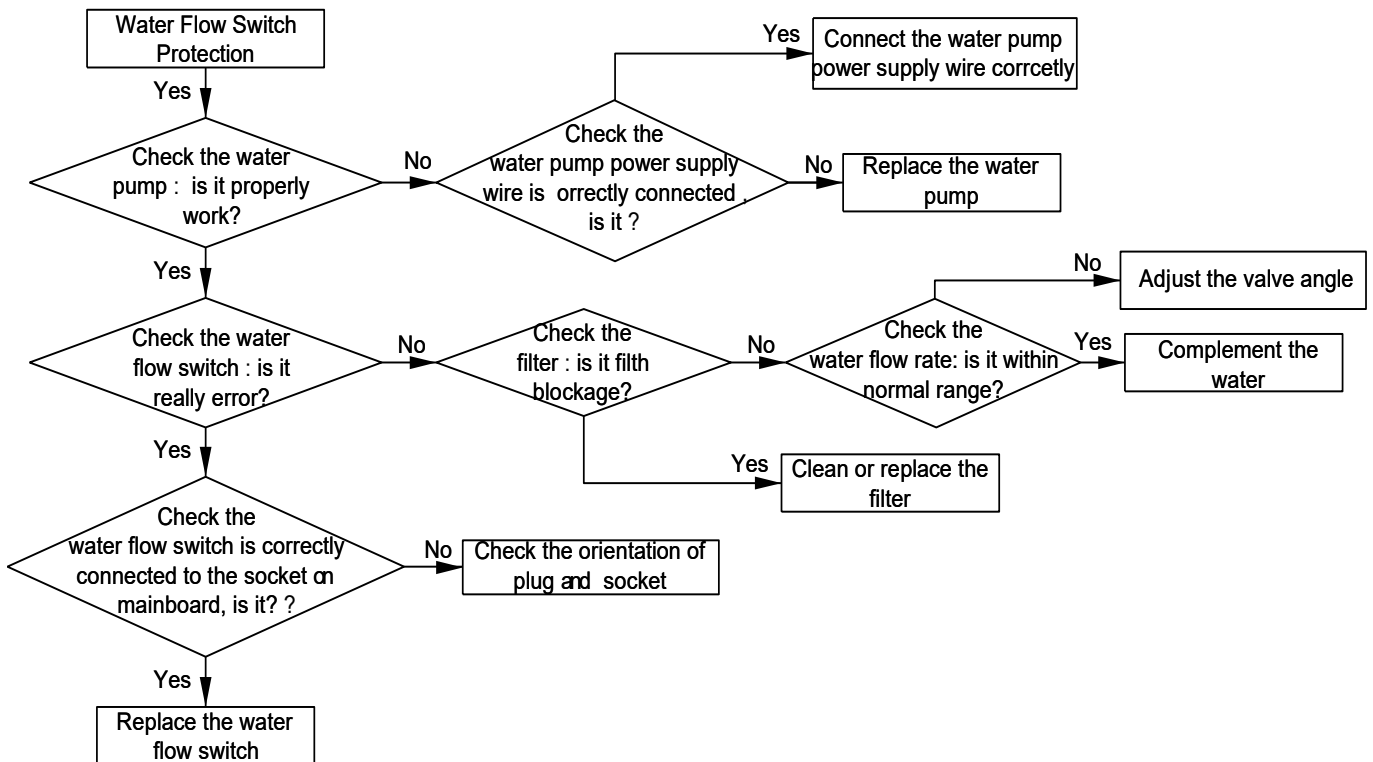

#### 4.4.6 “C6” Discharge Temperature Sensor Error

**Error display:** Compressor Module mainboard LED display screen

**Error judgment condition and method:**

The resistance value of discharge temperature sensor is 50 KΩ;

Sample the AD value of temperature sensor through temperature sensor detecting circuit and judge the range of AD value, If the sampling AD value exceeds upper limit and lower limit in 5 seconds continuously, report the error.

**Possible reason:**

- Poor connection between temperature sensor and terminal in mainboard
- Temperature sensor is abnormal
- Detecting circuit is abnormal

**Troubleshooting:**

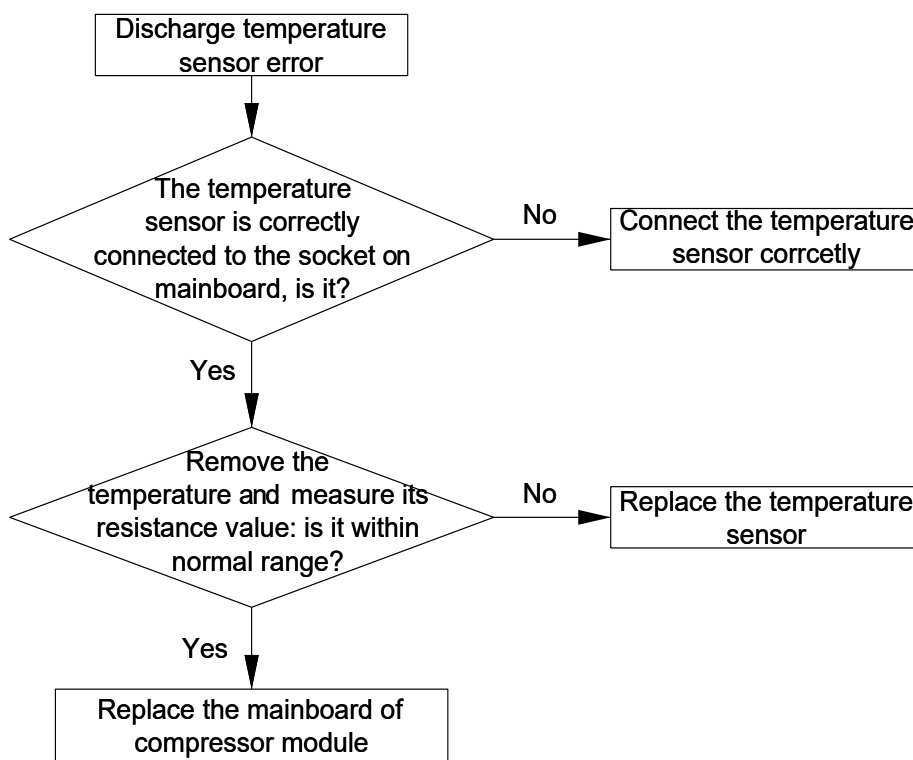

### 4.4.7 “H5” IPM Protection

**Error display:** Compressor Module mainboard LED display screen

**Error judgment condition and method:**

When power is connected and drive chip received IPM lead that is of low level, then it is IPM module malfunction. System will shut down for protection.

**Possible reason:**

- Compressor 3-phase wire connection is lack of phase or phase-reversed.
- System is overloaded and compressor current is too large.
- IPM module is damaged.
- IPM module's 15V power supply is lower than 13.5V.
- 6-line PWM signal and the corresponding element are abnormal.
- Compressor current sampling circuit element is damaged or drive chip current sampling AD terminal is abnormal.
- Compressor is damaged.

**Troubleshooting:**

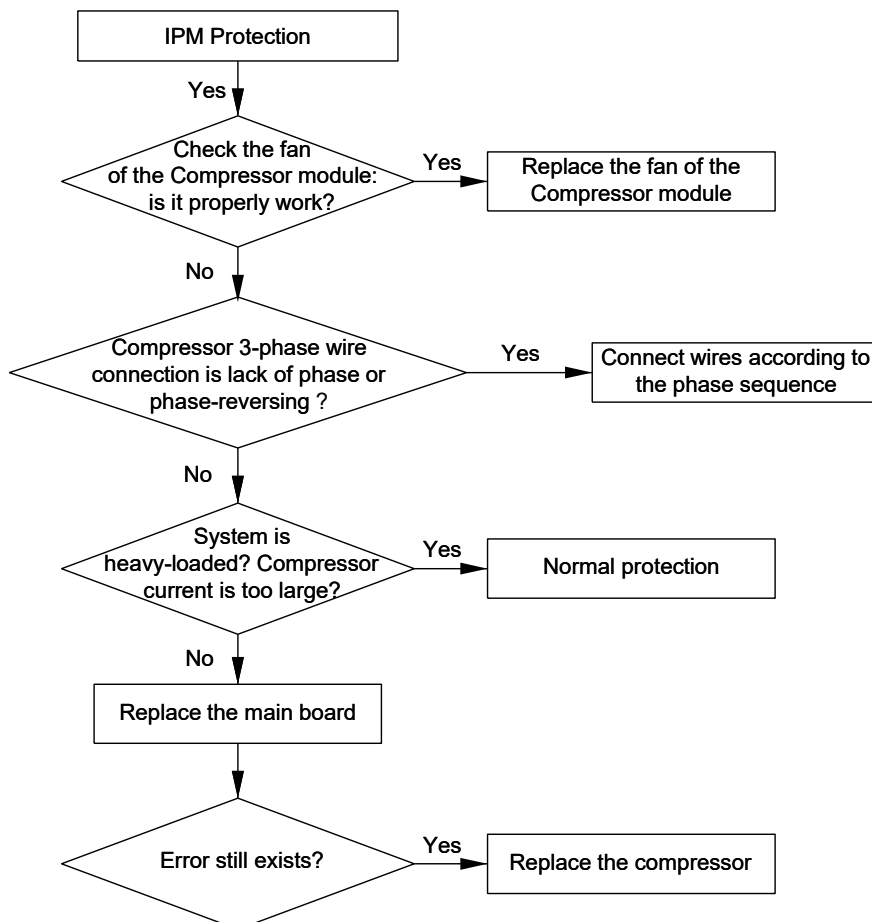

#### 4.4.8 “HC” PFC Protection

**Error display:** Compressor Module mainboard LED display screen

**Error judgment condition and method:**

After power is connected, and drive chip received PFC lead that is of low level, then it is PFC module malfunction. System will shut down for protection.

**Possible reason:**

- Power grid voltage is abnormal.
- Main board PFC module is damaged.
- Main board PFC module's 15V power supply is lower than 13.5V.
- Main board PWM signal for PFC and the corresponding element are abnormal.
- Main board PFC current sampling circuit element is damaged or drive chip current sampling AD terminal is abnormal.

**Troubleshooting:**

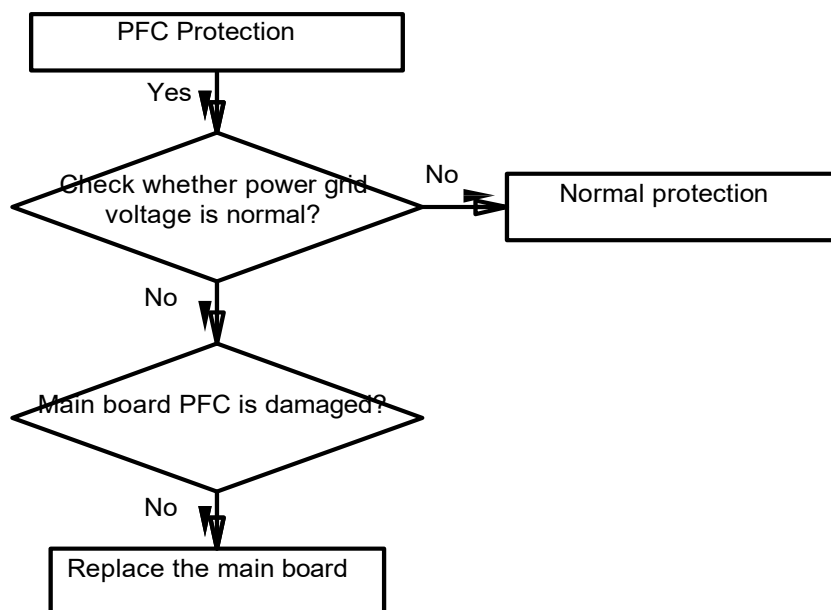

#### 4.4.9 “P8” High Driver Module Temperature Protection

**Error display:** Compressor module mainboard LED display screen

**Error judgment condition and method:**

If IPM module temperature exceeds the set protection value, then it can be judged that driver module temperature is too high and system will shut down for protection.

**Possible reason:**

- Thermal grease is not applied or not evenly applied to the module, or there is other substance on the back of the module.
- The module securing screws are not tightened up.
- Compressor module mainboard temperature sampling circuit element is damaged or drive chip temperature sampling AD terminal is abnormal.

**Troubleshooting:**

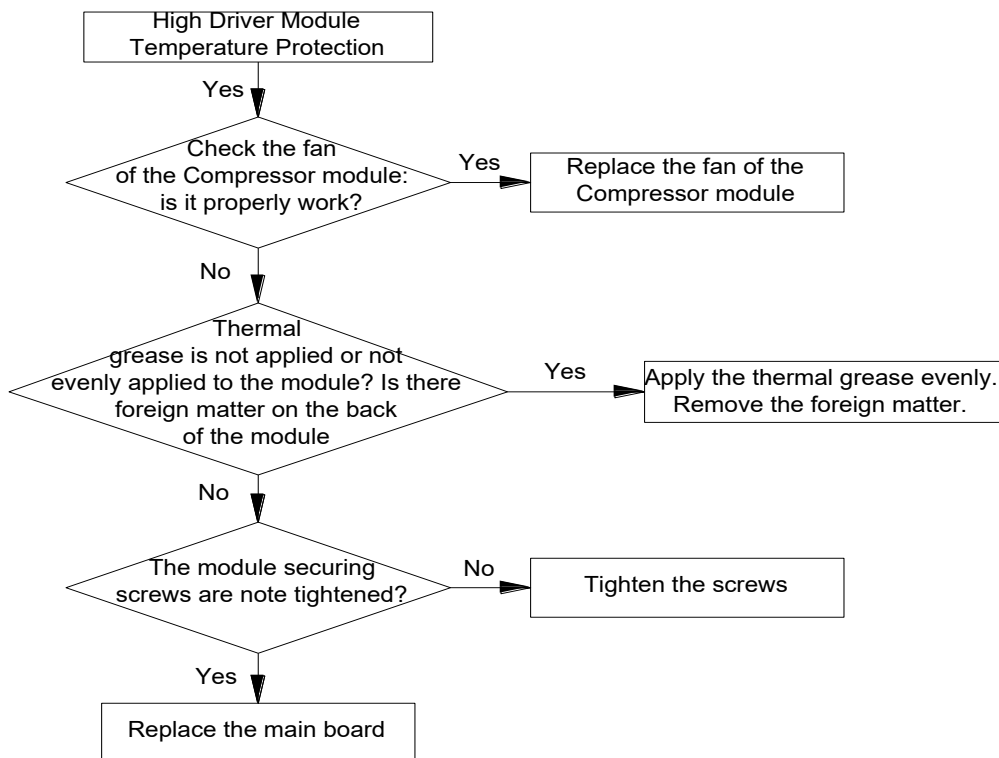



#### 4.4.10 “H3” High-Pressure Sensor Error

**Error display:** Compressor module mainboard LED display screen

Sample the AD value of pressure sensor through pressure sensor detecting circuit and judge the range of AD value, If the sampling AD value exceeds upper limit and lower limit in 5 seconds continuously, report the error.

- Poor connection between pressure sensor and terminal in mainboard
- Pressure sensor is abnormal
- Detecting circuit is abnormal

**Troubleshooting:**

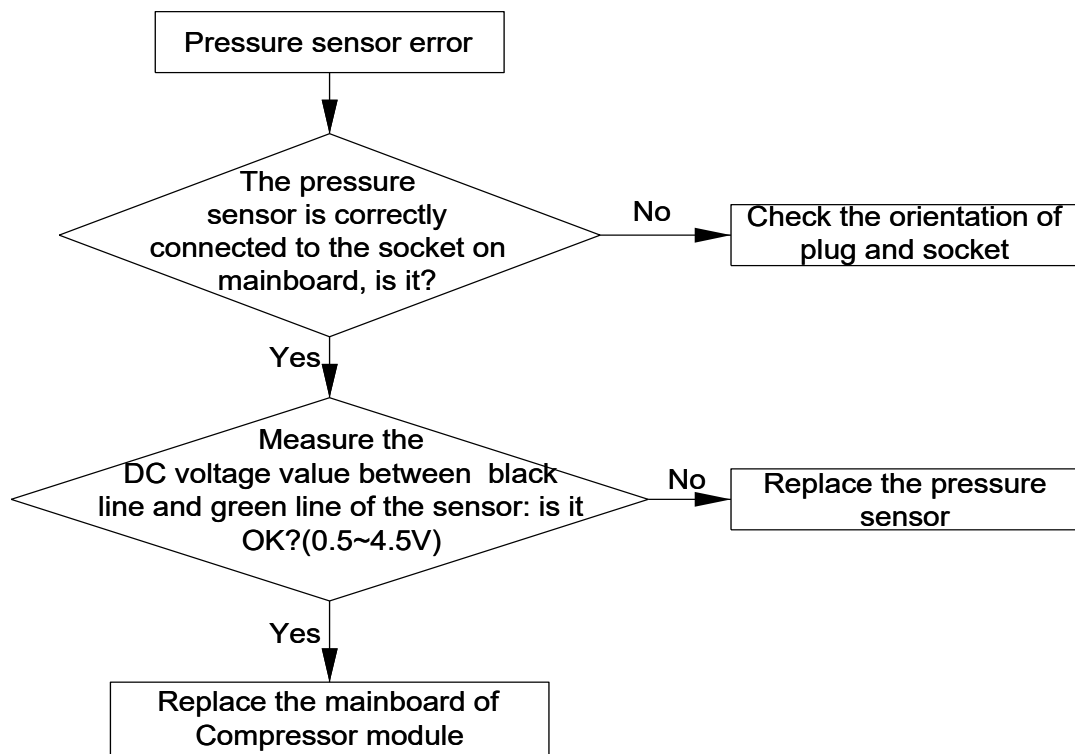

#### 4.4.11 “dc” Suction Temperature Sensor Error

**Error display:** Compressor module mainboard LED display screen

**Error judgment condition and method:**

The resistance value of suction temperature sensor is 20 KΩ;

Sample the AD value of temperature sensor through temperature sensor detecting circuit and judge the range of AD value, If the sampling AD value exceeds upper limit and lower limit in 5 seconds continuously, report the error.

**Possible reason:**

- Poor connection between temperature sensor and terminal in mainboard interface
- Temperature sensor is abnormal
- Detecting circuit is abnormal

**Troubleshooting:**

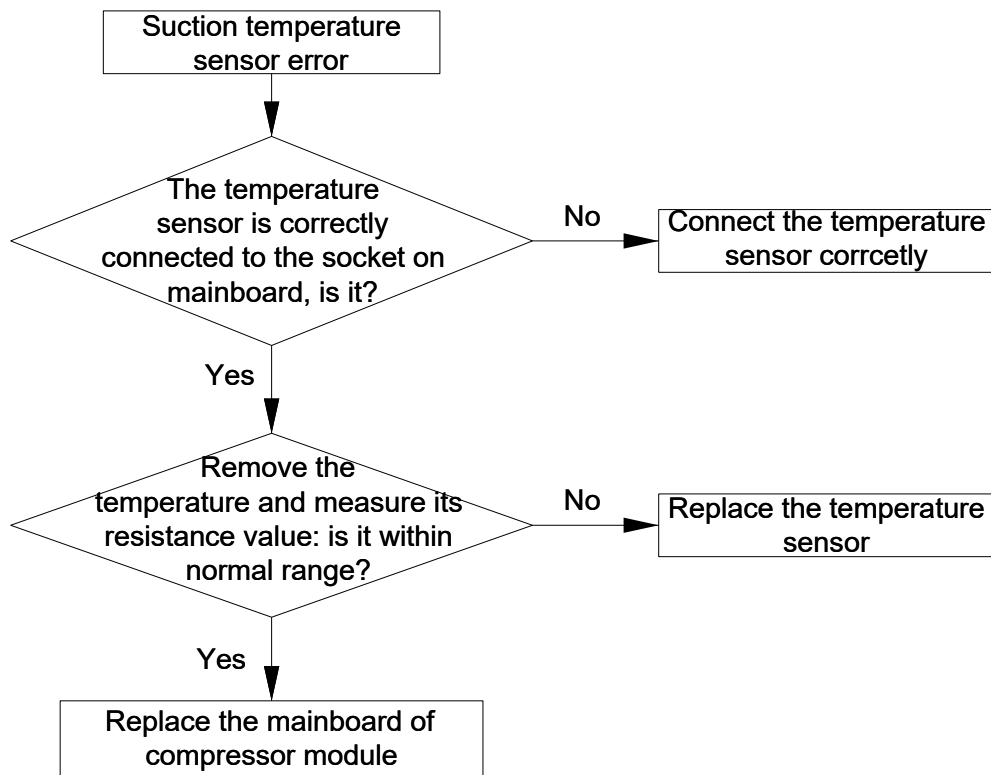

#### 4.4.12 “FB” Water Inlet Temperature Sensor Error

**Error display:** Compressor module mainboard LED display screen

**Error judgment condition and method:**

The resistance value of water inlet temperature sensor is 20 KΩ;

Sample the AD value of temperature sensor through temperature sensor detecting circuit and judge the range of AD value, If the sampling AD value exceeds upper limit and lower limit in 5 seconds continuously, report the error.

**Possible reason:**

- Poor connection between temperature sensor and terminal in mainboard interface
- Temperature sensor is abnormal
- Detecting circuit is abnormal

**Troubleshooting:**

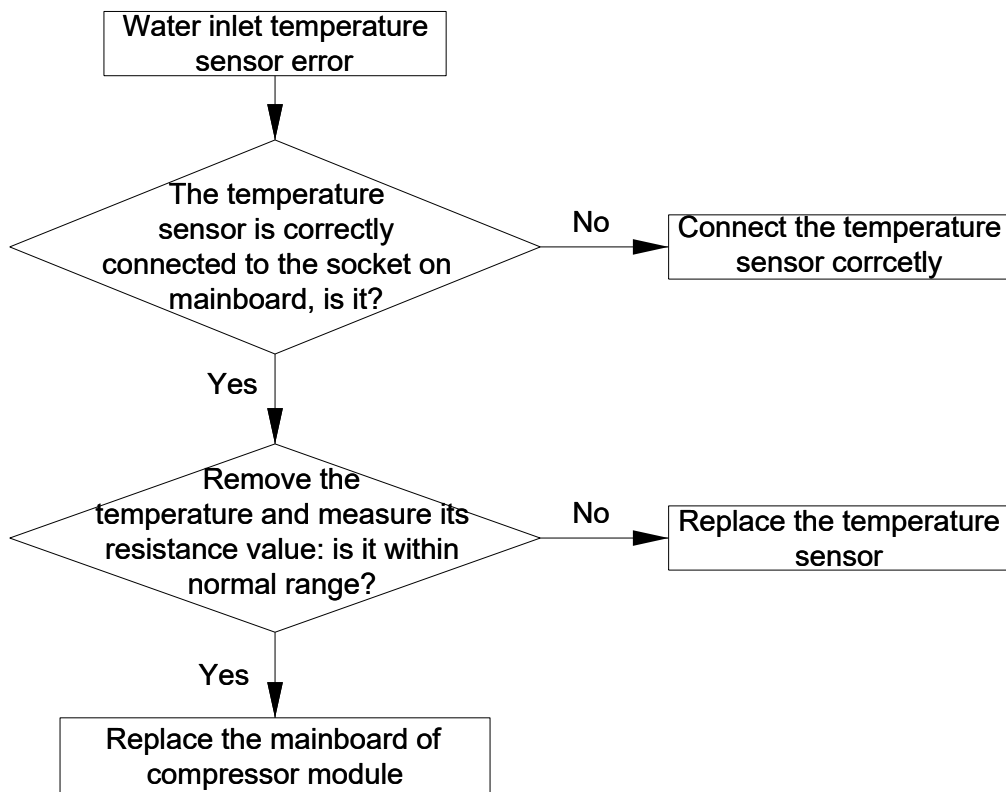

### 4.4.13 “FM” Water Outlet Temperature Sensor Error

**Error display:** Compressor module mainboard LED display screen

**Error judgment condition and method:**

The resistance value of water outlet temperature sensor is 20 KΩ;

Sample the AD value of temperature sensor through temperature sensor detecting circuit and judge the range of AD value, If the sampling AD value exceeds upper limit and lower limit in 5 seconds continuously, report the error.

**Possible reason:**

- Poor connection between temperature sensor and terminal in mainboard interface
- Temperature sensor is abnormal
- Detecting circuit is abnormal

**Troubleshooting:**

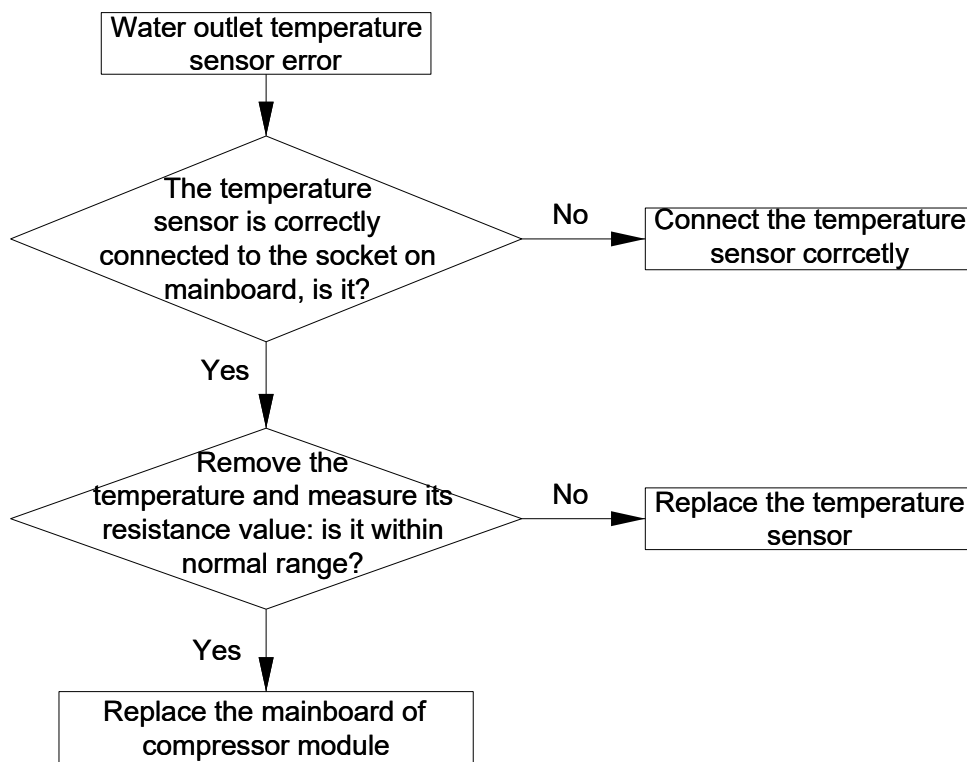

#### 4.4.14 “A7” Liquid Pipe Temperature Sensor Error

**Error display:** Compressor module mainboard LED display screen

**Error judgment condition and method:**

The resistance value of liquid pipe temperature sensor is 20 K $\Omega$ ;

Sample the AD value of temperature sensor through temperature sensor detecting circuit and judge the range of AD value, If the sampling AD value exceeds upper limit and lower limit in 5 seconds continuously, report the error.

**Possible reason:**

- Poor connection between temperature sensor and terminal in mainboard interface
- Temperature sensor is abnormal
- Detecting circuit is abnormal

**Troubleshooting:**

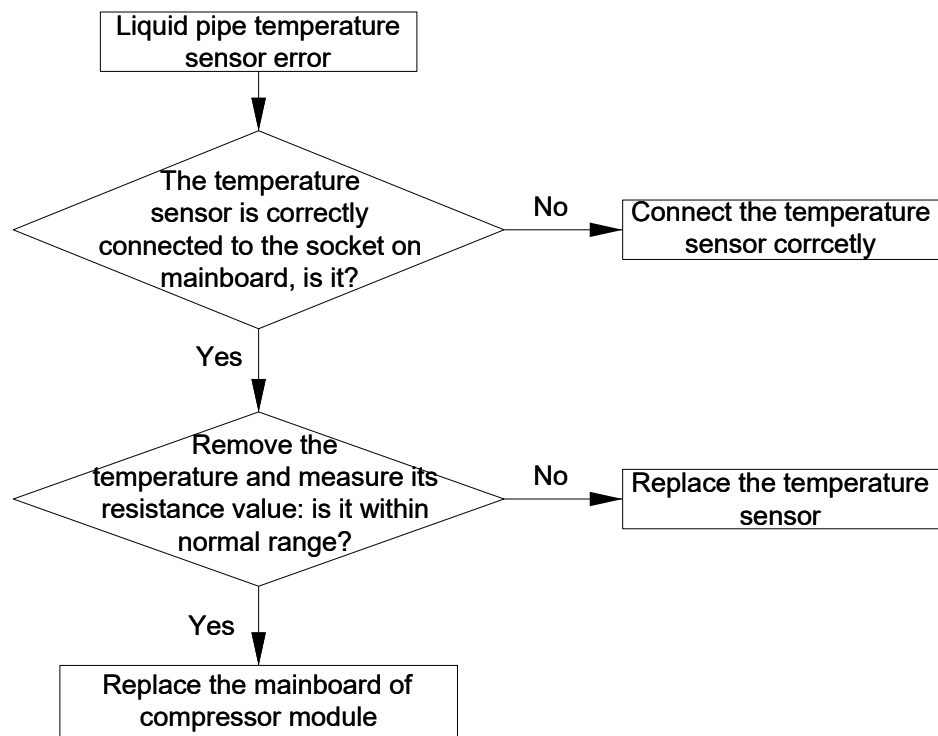

#### 4.4.15 “C2” In-Tube Temperature Sensor Error

**Error display:** Compressor module mainboard LED display screen

**Error judgment condition and method:**

The resistance value of in-tube temperature sensor is 20 KΩ;

Sample the AD value of temperature sensor through temperature sensor detecting circuit and judge the range of AD value, If the sampling AD value exceeds upper limit and lower limit in 5 seconds continuously, report the error.

**Possible reason:**

- Poor connection between temperature sensor and terminal in mainboard interface
- Temperature sensor is abnormal
- Detecting circuit is abnormal

**Troubleshooting:**

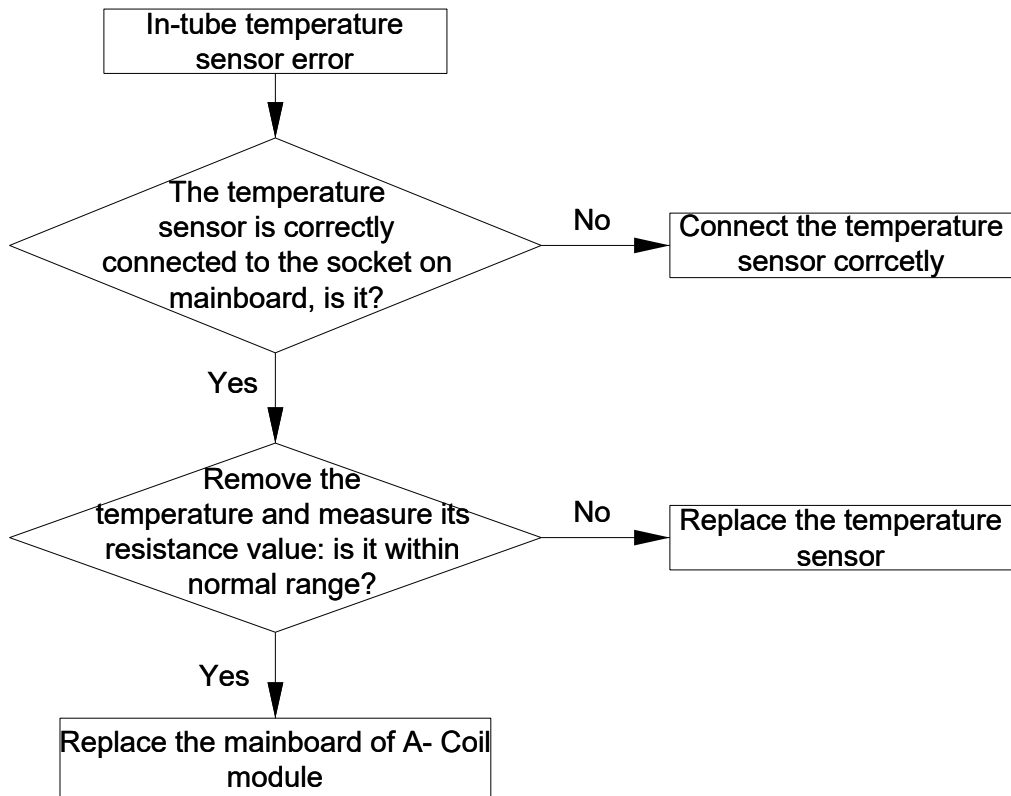

#### 4.4.16 “Cb” Gas Pipe Temperature Sensor Error

**Error display:** Compressor module mainboard LED display screen

**Error judgment condition and method:**

The resistance value of gas pipe temperature sensor is 20 KΩ

Sample the AD value of temperature sensor through temperature sensor detecting circuit and judge the range of AD value, If the sampling AD value exceeds upper limit and lower limit in 5 seconds continuously, report the error.

**Possible reason:**

- Poor connection between temperature sensor and terminal in mainboard interface
- Temperature sensor is abnormal
- Detecting circuit is abnormal

**Troubleshooting:**

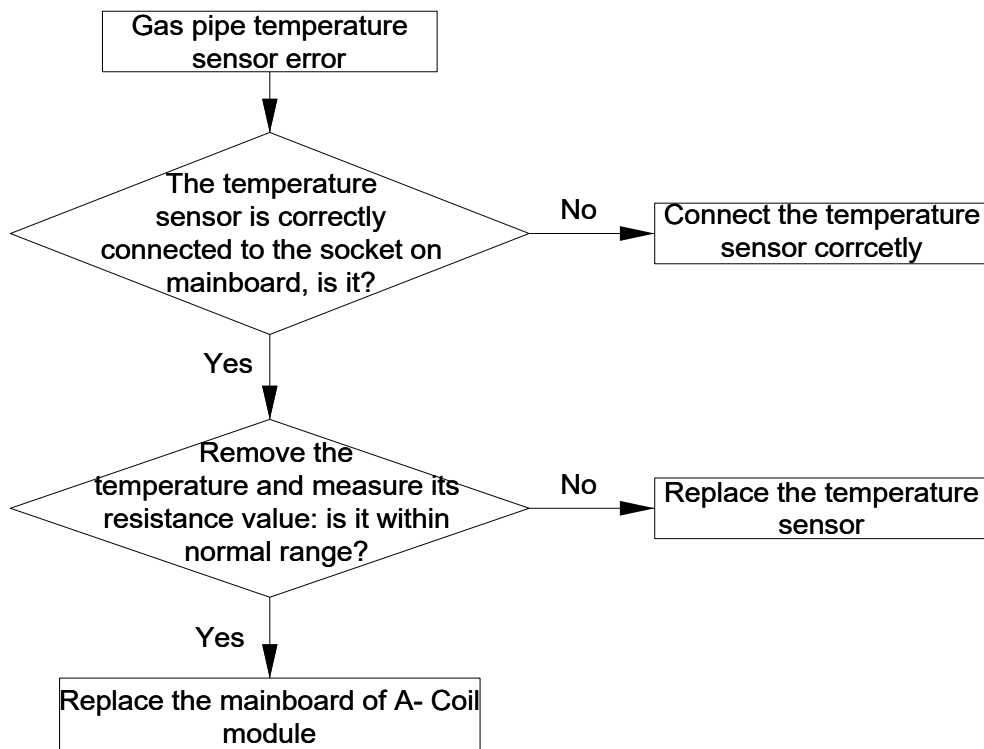

#### 4.4.17 “C1” Return Air Temperature Sensor Error

**Error display:** Compressor module mainboard LED display screen

**Error judgment condition and method:**

The resistance value of return air temperature sensor is 15 KΩ

Sample the AD value of temperature sensor through temperature sensor detecting circuit and judge the range of AD value, If the sampling AD value exceeds upper limit and lower limit in 5 seconds continuously, report the error.

**Possible reason:**

- Poor connection between temperature sensor and terminal in mainboard interface
- Temperature sensor is abnormal
- Detecting circuit is abnormal

**Troubleshooting:**

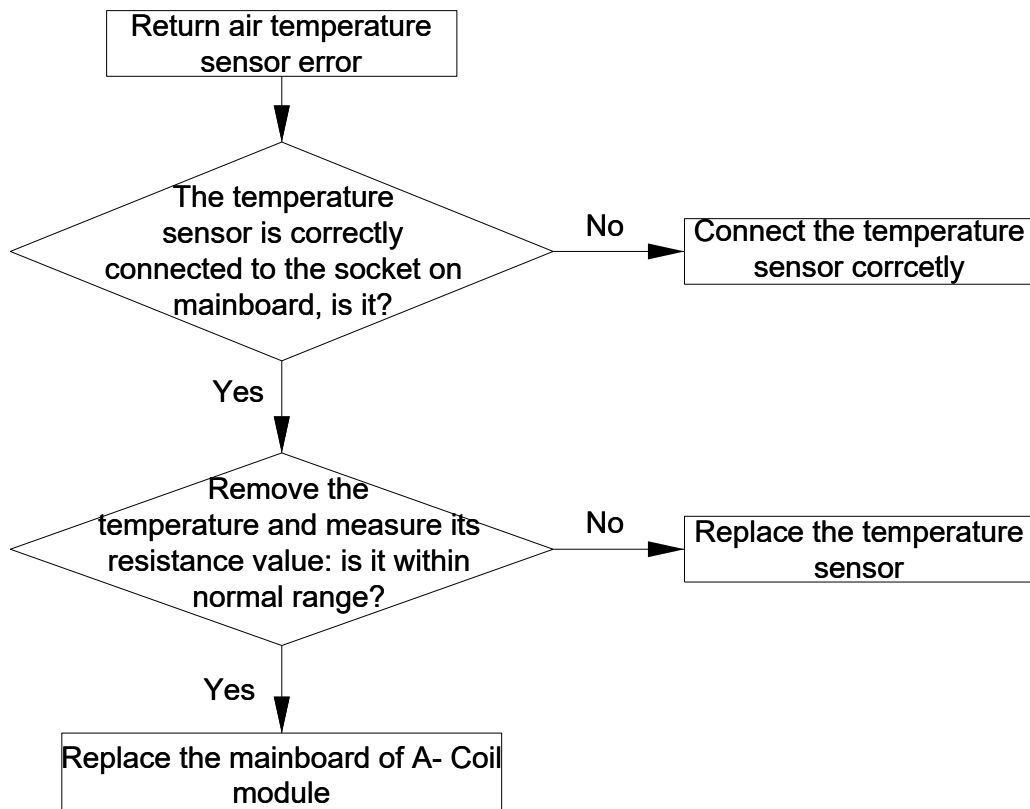



#### 4.4.18 “E6” Communication Error

**Error display:** Compressor module mainboard LED display screen

**Error judgment condition and method:**

The communication between the compressor module and A-Coil module is bad, the display screen of the compressor module shows the error code, the green light of the A-Coil module mainboard will light for 1 second then flash 6 times. The unit will automatically restart after the communication has recovered for 30 seconds continuously.

**Possible reason:**

- Poor connection of compressor module mainboard terminal
- Poor connection of A-Coil module mainboard terminal
- The power of A-Coil module or compressor module is cut off
- Detecting circuit is abnormal
- Interference of other equipment

**Troubleshooting:**

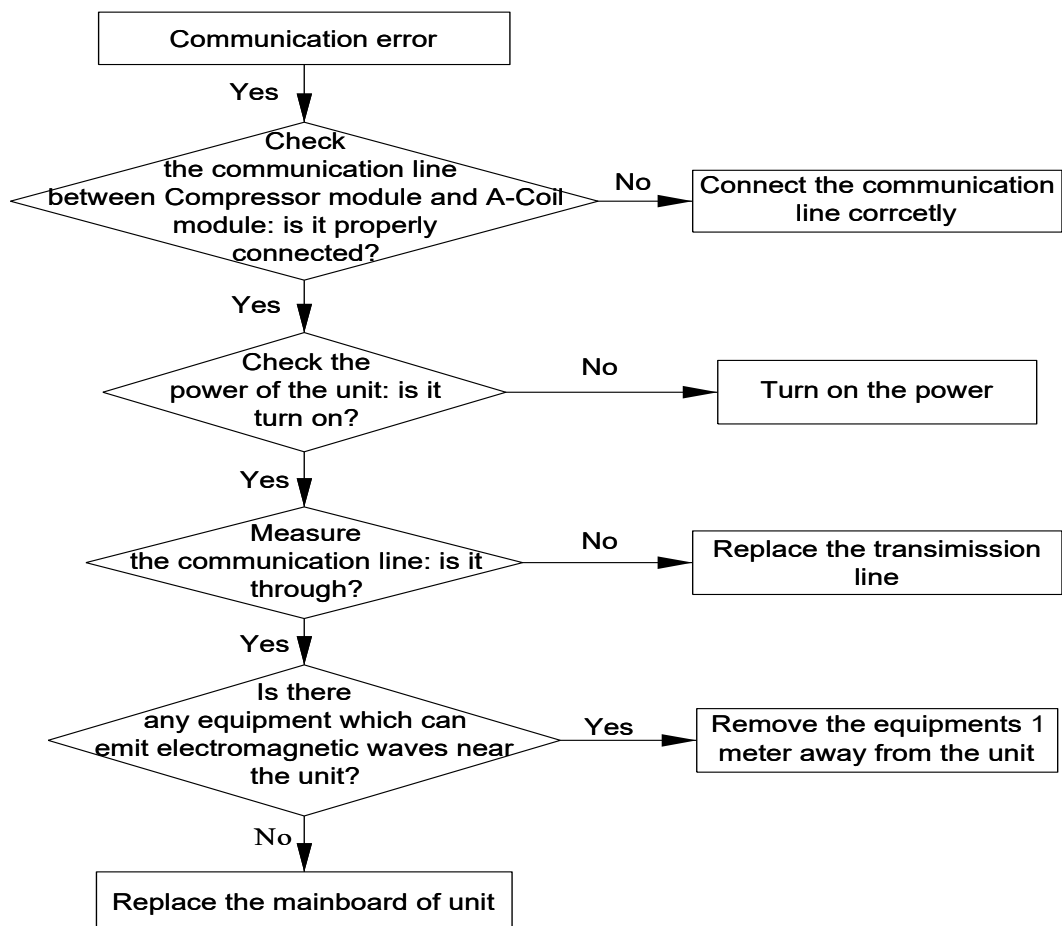

#### 4.4.19 “PL” DC Bus Under-Voltage Protection or DC Bus Voltage Drop Error

**Error display:** Compressor module mainboard LED display screen

**Error judgment condition and method:**

When compressor is running and there is no other error, if busbar voltage is lower than the set value for low voltage protection, the DC Bus Under-Voltage Protection or DC Bus Voltage Drop Error is reported. The display screen of the main board displays the error code, and the unit shuts down.

**Possible reason:**

- Voltage is abnormal.
- Busbar voltage sampling circuit element is damaged or busbar voltage sampling AD terminal is abnormal.

**Troubleshooting:**

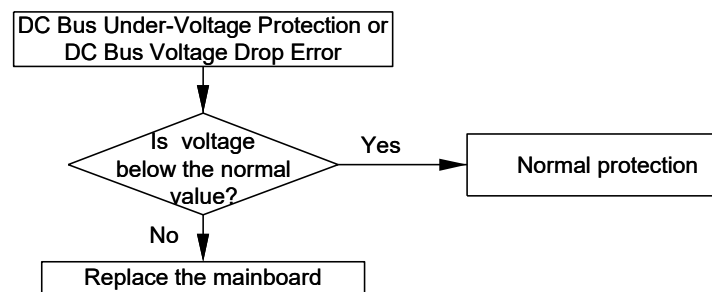

#### 4.4.20 “PH” DC Bus Over-Voltage Protection

**Error display:** Compressor module mainboard LED display screen

**Error judgment condition and method:**

If there is no other malfunction and the busbar voltage is higher than the set value for high voltage protection, then it can be judged that DC bus over-voltage protection occurs, the display screen of the compressor module shows the error code. System will shut down for protection.

**Possible reason:**

- Voltage is abnormal.
- Busbar voltage sampling circuit element is damaged or busbar voltage sampling AD terminal is abnormal.

**Troubleshooting:**

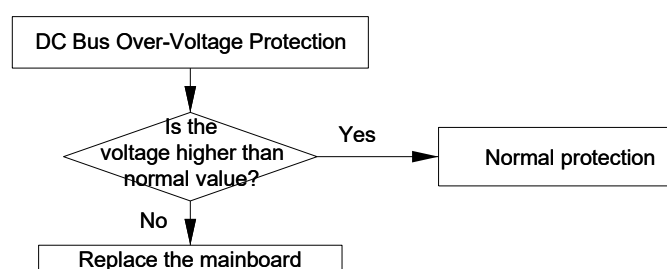

#### 4.4.21 “PU” Charging Circuit Error

**Error display:** Compressor module mainboard display screen

**Error judgment condition and method:**

When the charge loop starts to get charged and the busbar voltage cannot reach the set value in a certain period of time, the charging circuit error is reported, the display screen of the compressor module shows the error code. System will shut down for protection.

**Possible reason:**

- Voltage is too low.
- Charge loop element is abnormal.
- Busbar voltage sampling circuit element is damaged or Busbar voltage sampling AD terminal is abnormal.

**Troubleshooting:**

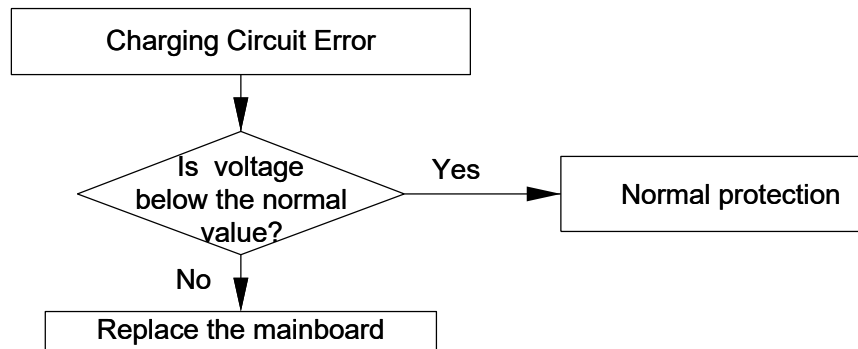

#### 4.4.22 “LF” Power Protection

**Error display:** Compressor module mainboard LED display screen

**Error judgment condition and method:**

When the power of the unit is detected to be higher than normal for a continuous period of time, the system will enter Power Protection. The unit shuts down. The display screen of the compressor module shows the error code. After the compressor is shut down for a period of time, if the power is detected less than the limit value, the error is cleared, and the unit will return to normal and restart. If Power Protection occurs multiple times within a certain period of time, the error cannot be automatically cleared and can only be cleared through manual power off.

**Possible reason:**

- Power is too high
- Detecting circuit is abnormal.

**Troubleshooting:**

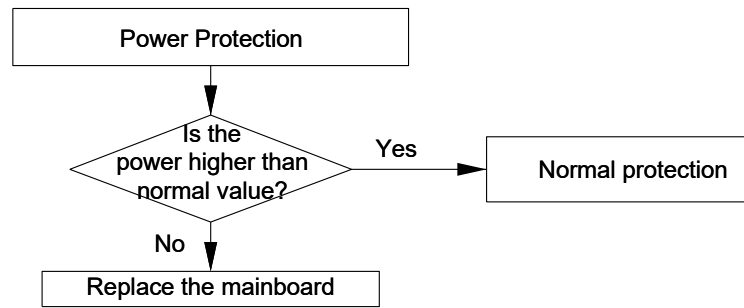

#### 4.4.23 “E5” Current Protection

**Error display:** Compressor module mainboard LED display screen

**Error judgment condition and method:**

When the power of the unit is detected to be higher than normal for a continuous period of time, the system will enter Current Protection. The unit shuts down. The display screen of the compressor module shows the error code. After the compressor is shut down for a period of time, if the current is detected less than the limit value, the error is cleared, and the unit will return to normal and restart. If Current Protection occurs multiple times within a certain period of time, the error cannot be automatically cleared and can only be cleared through manual power off.

**Possible reason:**

- The unit current is too high
- Detecting circuit is abnormal.

**Troubleshooting:**

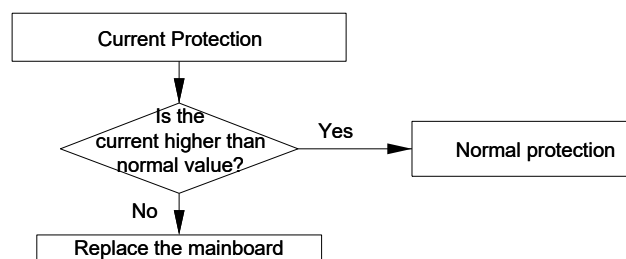

#### 4.4.24 “E0” Fan Error

**Error display:** Compressor module mainboard LED displayer

**Error judgment condition and method:**

If the fan error is detected for a continuous period of time, the display screen of the compressor module shows the error code, the green light of the A-Coil module mainboard will light for 1 second then flash 2 times. If the detection returns to normal for a continuous period of time, the unit will return to normal operation. If the

continuous trigger protection exceeds a certain number of times, the error cannot be automatically cleared, the need to manually power off to clear the fault.

If the unit receives fan signal from the thermostat, but the fan does not operate, it is determined that the fan signal wiring between thermostat and the unit is abnormal, and the fan error is reported, the error cannot be automatically cleared, and can only be manually powered off to clear the error.

**Possible reason:**

- Fan error
- Detecting circuit is abnormal
- The fan signal wiring between thermostat and the unit is abnormal

**Troubleshooting:**

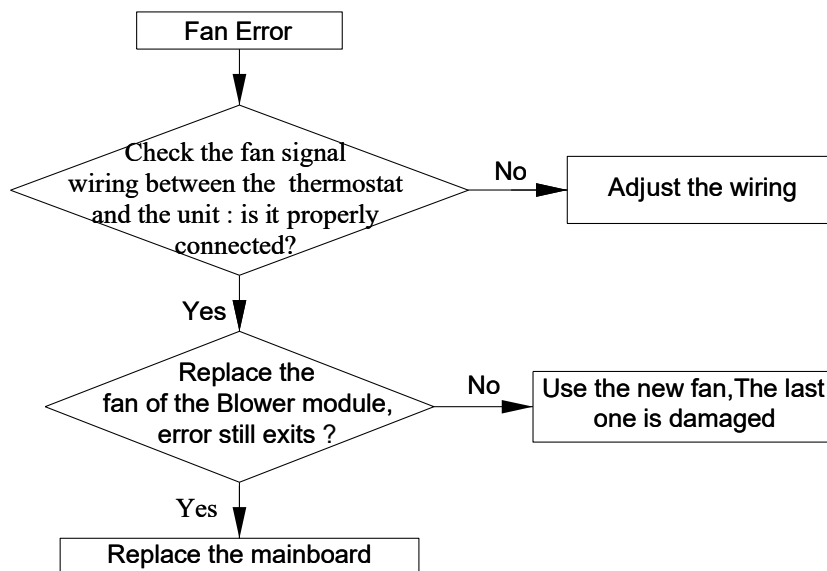

#### 4.4.25 “C9” Chip Error

**Error display:** Compressor module mainboard LED display screen

**Error judgment condition and method:**

If unit detect chip self-test abnormally, the display screen of the compressor module shows the error code, the error cannot be automatically cleared, and can only be manually powered off to clear the error.

**Possible reason:**

- Chip self-test abnormally

**Troubleshooting:**

Replace the mainboard of Compressor module.

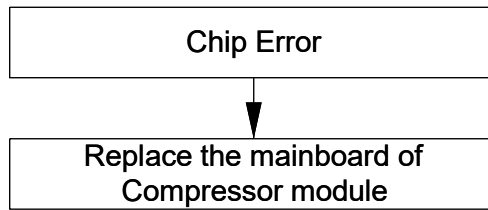

#### 4.4.26 “LP” Capacity DIP Switch Setting Error

**Error display:** Compressor module mainboard LED display screen

**Error judgment condition and method:**

If the capacity of the compressor module and the A-Coil module is not consistent for a period of time, the compressor module mainboard display screen shows the error code, the green light of the A-Coil module mainboard will light for 1 second then flash 1 times and the unit shuts down. The error need to be cleared by manually powering off the unit.

**Possible reason:**

- Compressor module and A-Coil module capacity dip switch setting error
- Detecting circuit is abnormal

**Troubleshooting:**

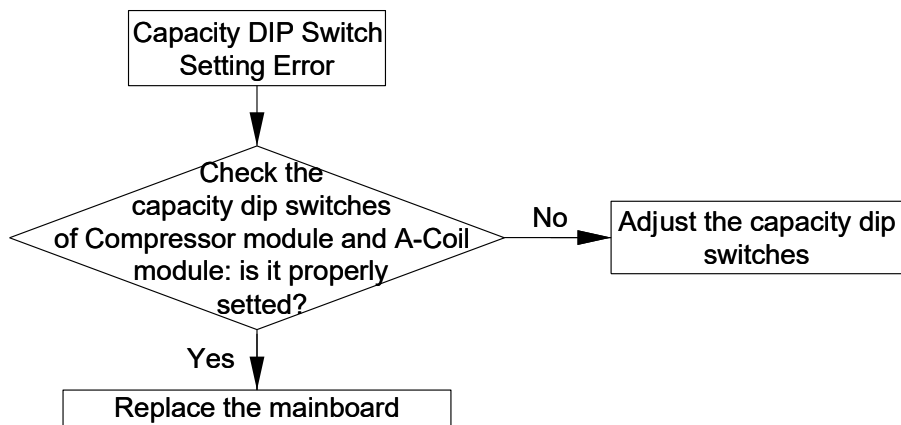

## 4.5 Failures Not Caused by Errors

(1) If your geothermal unit fails to function normally, please first check the following items before maintenance:

Problem	Cause	Corrective measure
The geothermal unit can't run.	If you turn off the unit and then immediately turn it on, in order to protect the compressor and avoid system overload, compressor will delay running for 3min.	Please wait for a while.
	Wire connection is wrong.	Connect wires according to the wiring diagram.
	Fuse or circuit breaker is broken.	Replace the fuse or switch on the circuit breaker.
	Power failure.	Restart after power is resumed.
	Power plug is loose.	Re-insert the power plug.
Bad cooling or heating effect.	Air inlet and outlet of the units have been blocked.	Clear the obstacles and keep the room for the units well ventilated.
	Improper temperature setting	Reset a proper temperature.
	Fan speed is too low.	Reset a proper fan speed.
	Doors or windows are open.	Close them.
	Exposed under direct sunshine.	Put on curtains or louvers in front of the windows.
	Too many heat sources in the room.	Remove unnecessary heat sources.
	Filter is blocked or dirty.	Clean or change the filter.

The following situations are not operation failures.

Problem	Time of occurrence	Cause
Mist comes from the geothermal unit.	During operation.	If the unit is running under high humidity, the wet air in the room will be quickly cooled down.
The geothermal unit generates some noise.	When the unit is turned on, it purrs.	When the system is just started, the refrigerant is not stable. About 30s later, the purr of the unit becomes low.
	About 40s after the unit first enables the heating mode	It's the sound of 4-way valve switching direction. The sound will disappear after the valve changes its direction.
	There is hissing sound when the unit is started or stopped and a slight hissing sound during and after operation.	It's the sound of gaseous refrigerant that stops flowing and the sound of drainage system.
	There is a sound of crunching	Because of temperature change,

Problem	Time of occurrence	Cause
	during and after operation.	front panel and other components may be swelled up and cause abrasion sound.
	There is a hissing sound when the unit is turned on or suddenly stopped during operation.	Because refrigerant suddenly stops flowing or changes the flow direction.
Dust comes from the geothermal unit.	The unit starts operation after being unused for a long time.	Dust inside the units come out together with the air.
The geothermal unit generates some smell.	During operation.	The room smell or the smell of cigarette comes out through the units.

**NOTICE:**

Check the above items and adopt the corresponding corrective measures. If the geothermal unit continues to function poorly, please stop the geothermal unit immediately and contact MRCOOL®'s authorized local service center. Ask our professional service staff to check and repair the unit.



## 5 Maintenance

### 5.1 System Diagram

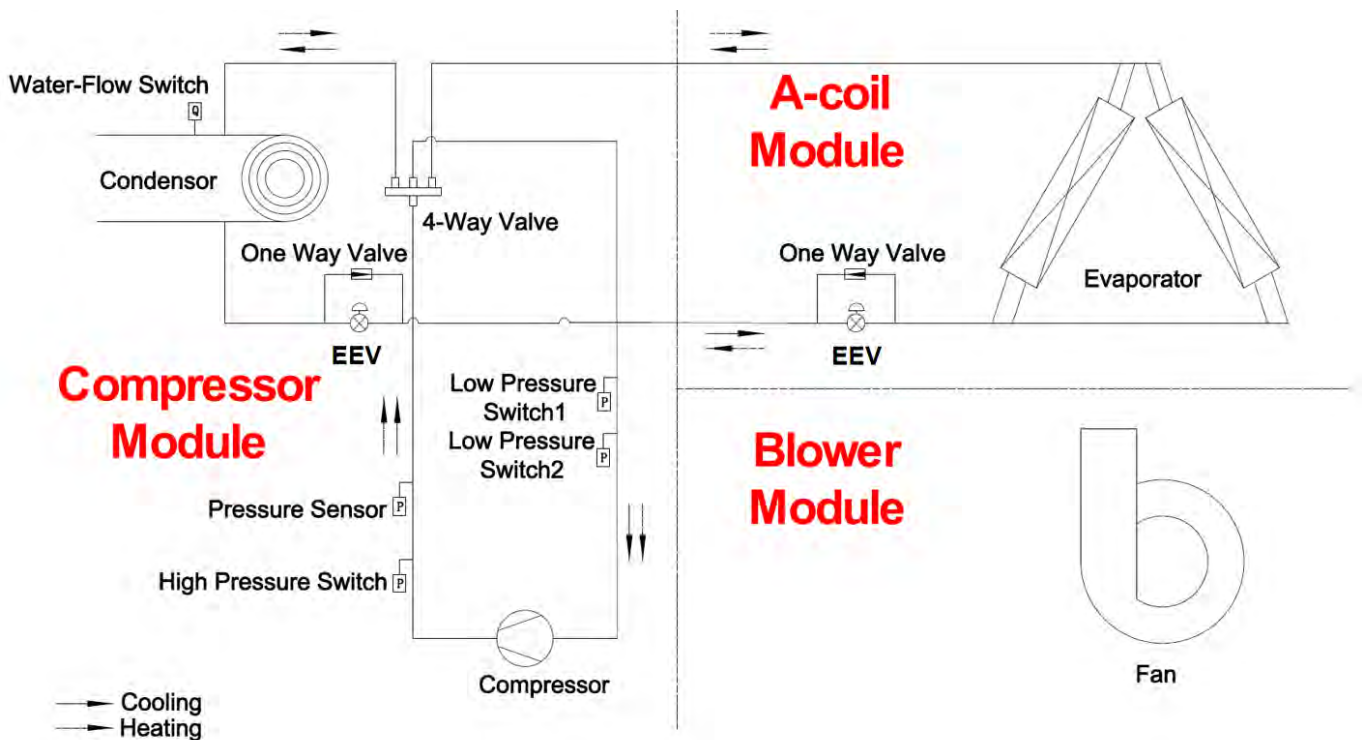

### 5.2 Connection Pipe Vacuum Pumping



- ① Make sure the outlet of vacuum pump is away from fire source and is well-ventilated.
- ② Before vacuum pumping, make sure the unit cut-off valves are closed.
- ③ When vacuum pumping, both the liquid pipe and the gas pipe must be pumped.

- (1) Remove the caps of the liquid pipe cut-off valve, gas pipe cut-off valve and also the service port.
- (2) Meanwhile the gas and liquid pipe cut-off valves should be kept closed in case of refrigerant leak.
- (3) Connect the hose used for evacuation to the vacuum pump.
- (4) Open the switch at the lower pressure side of the manifold valve assembly and start the vacuum pump. Meanwhile, the switch at the high pressure side of the manifold valve assembly should be kept closed, otherwise evacuation would fail.
- (5) The evacuation duration depends on the unit's capacity, generally.

Model	Time(min)
GCSHPM060IN GCSCAM060GN	35
GCSHPM048IN GCSCAM048GN	35

And verify if the pressure gauge at the low pressure side of the manifold valve assembly reads -0.1Mpa

(-750mmHg), if not, it indicates there is leak somewhere. Then, close the switch fully and then stop the vacuum pump.

- (6) Wait for 10min to see if the system pressure can remain unchanged. If the pressure increase, there may be leakage.
- (7) Slightly open the liquid pipe cut-off valve and let some refrigerant go to the connection pipe to balance the pressure inside and outside of the connection pipe, so that air will not come into the connection pipe when removing the hose. Notice that the gas and liquid pipe cut-off valve can be opened fully only after the manifold valve assembly is removed.
- (8) Place back the caps of the liquid pipe cut-off valve, gas pipe cut-off valve and also the service port.

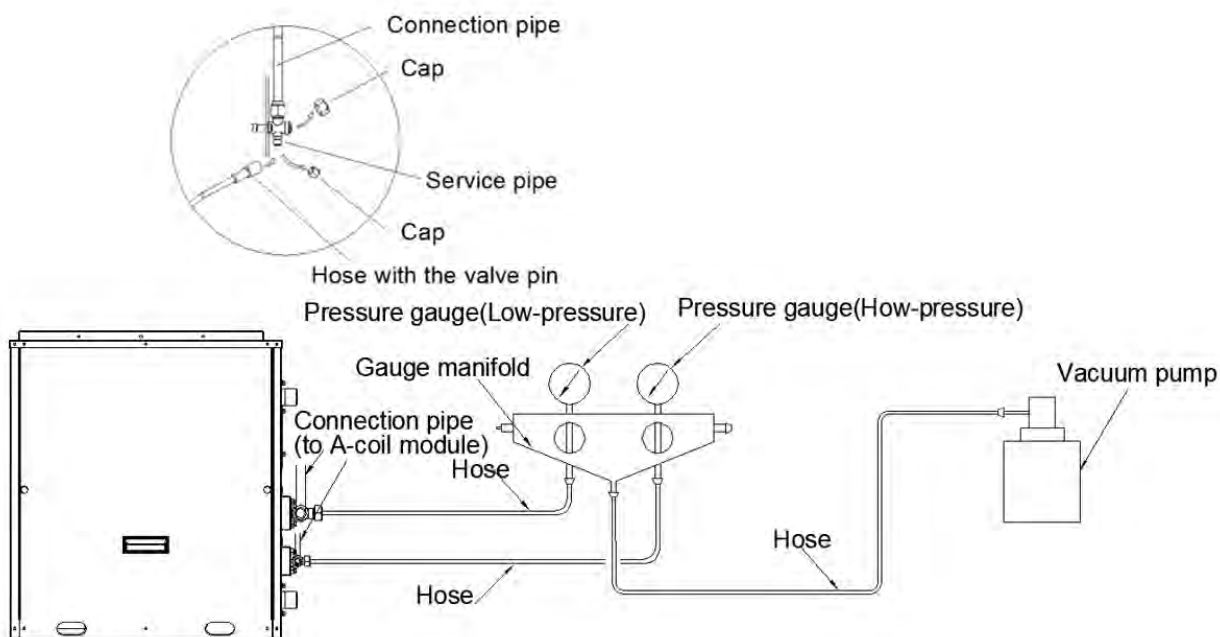

## 5.3 Refrigerant Charging

### Pre-charging

Step 1: Connect the high pressure gauge line to the valve of liquid pipe and connect the low pressure gauge line to the valve of gas pipe. Connect the middle gauge line to the vacuum pump. Power on the vacuum pump and perform vacuum drying.

Step 2: After vacuum drying, close the high and low pressure gauge valves. Then remove the middle gauge line from the connector of vacuum pump. Then connect to the refrigerant tank.

Step 3: Loosen the middle gauge line from the connector of pressure gauge to a proper extent and slightly open the valve of refrigerant tank. Evacuate the middle gauge line. Then tighten up the connector again and completely open the valve of refrigerant tank at the same time.

Step 4: Keep the refrigerant tank erect and put it on an electronic scale. Record the current weight as  $m_1$ .

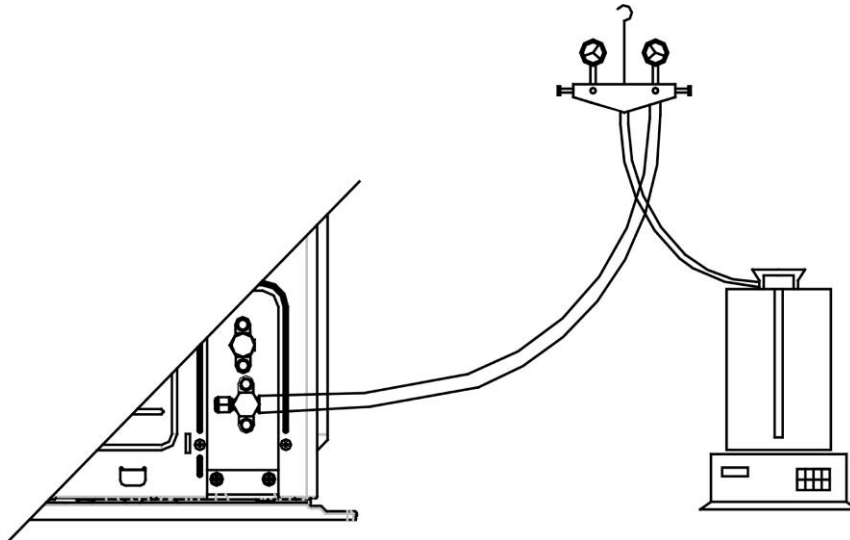

Step 5: Open the high pressure gauge valve (Keep the low pressure gauge valve closed). Then charge refrigerant into the system. Meanwhile, record the weight of refrigerant tank as  $m_2$ .

Step 6:  $m_1 - m_2 = m$ . If  $m$  equals to the required charging quantity  $M$ , close the valve of refrigerant tank at once. Then move to step 8.

Step 7: If you can't continue to charge refrigerant into the system and the quantity of charged refrigerant is less than the required charging quantity, then record the current quantity of charged refrigerant:

$$m = m_1 - m_2$$

$$m' = M - m$$

The remaining charging quantity is:  $m' = M - m$

Step 8: After charging, remove the pressure gauge.

Refrigerant charging when unit is turned on:

Step 1: Close the valve of refrigerant tank. First remove the pressure gauge lines and connect the compressor module and the A-Coil module. Then reconnect the pressure gauge lines. Connect the low pressure gauge line to the other joint of gas pipe cut-off valve and connect the high pressure gauge line to the liquid pipe cut-off valve. Connect the middle gauge line to the vacuum pump. Power on the vacuum pump and perform vacuum drying.

Step 2: After vacuum drying, close the high and low pressure gauge valves. Then remove the middle gauge line from the connector of vacuum pump. Then connect to the refrigerant tank.

Step 3: Loosen the middle gauge line from the connector of pressure gauge to a proper extent and slightly open the valve of refrigerant tank. Evacuate the middle gauge line. Then tighten up the connector again and completely open the valve of refrigerant tank at the same time.

Step 4: Turn on the units and let it run for a while.

Step 5: Open the low pressure gauge valve (Keep the high pressure gauge valve closed). Then charge in the remaining charging quantity m`.

Step 6: After all required refrigerant is charged in, close the valve of refrigerant tank.

Step 7: Remove the pressure gauge to finish the refrigerant charging work.

Procedure of refrigerant charging

Following is the supplementary requirement for refrigerant charging on the basis of normal procedure:

- 1) Make sure that when charging refrigerant into the system, no other types of refrigerant will be mixed.  
The pipeline for refrigerant charging should be as short as possible to reduce the amount of refrigerant left in it.
- 2) The refrigerant tank should stand erect.
- 3) Make sure the refrigerating system is already grounded before refrigerant charging.
- 4) When charging is completed (or not yet completed), stick a label on the system.
- 5) Before re-charging refrigerant into the system, use oxygen-free nitrogen to perform pressure test. When charging is completed, perform leak test before trial running. Before leaving the workplace, perform a leak test again.

## 5.4 Maintenance of Major Components

### 5.4.1 How to replace the compressor

#### 5.4.1.1 Diagnosis of compressor failure

A. On condition that the unit can be started up

Step 1:

If the unit can be started up, then start it up to check the current of the faulted compressor. Use a pressure gauge to measure the pressure of the big and small valves. Connect with a computer to monitor the data. Refer to the following table based on the recommended working current. The electric current of an inverter compressor will be different under different rotation speed or different working conditions. If the compressor is working at 60Hz, the working current corresponding to different condensing temperature and evaporating temperature is shown below:

Inverter compressor

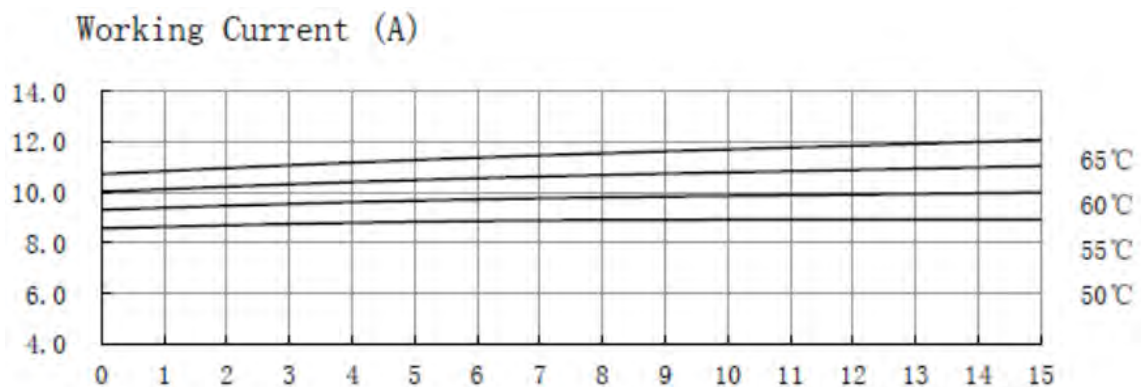

Step 2:

Judge whether the operating noise of the compressor is normal, and whether there is a sharp noise or obvious scraping. If there is a normal compressor working nearby, compare their operating noise.

Step 3:

Examine whether the electronic expansion valve of the unit is active and whether the 4-way valve works or not. How to examine:

(1) Electronic expansion valve:

The electronic expansion valve will be reset every time when the unit is powered on or off. Touch the valve and you can feel the movement of the valve spool. In the last stage of the reset process, you will hear the click of the valve and feel its vibration.

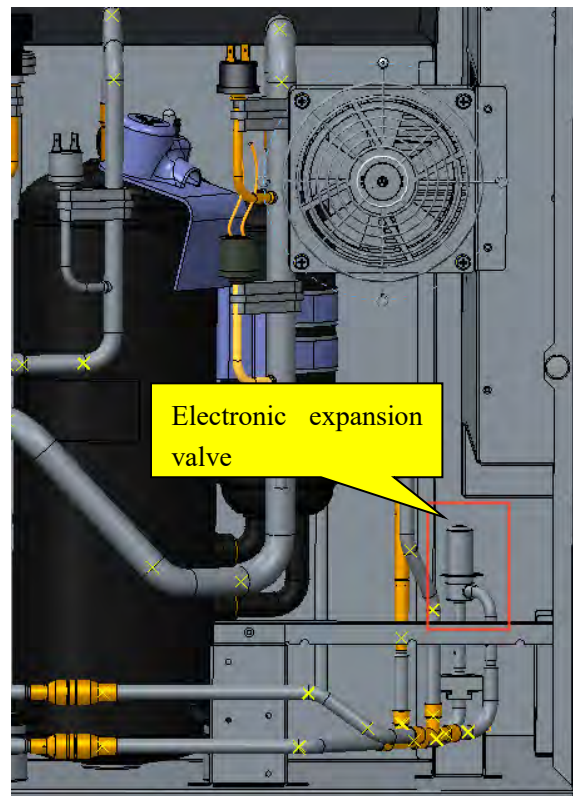

Touch the electronic expansion valve:

a. Touch the top of the electronic expansion valve and you can feel their move as they are reset upon startup.

b. Make sure the coil is fixed firmly.

(2) 4-way valve:

During normal operation, the 4 copper tubes that connect to the valve will have different temperature. When the 4-way valve is working, it will generate some noise and vibration.

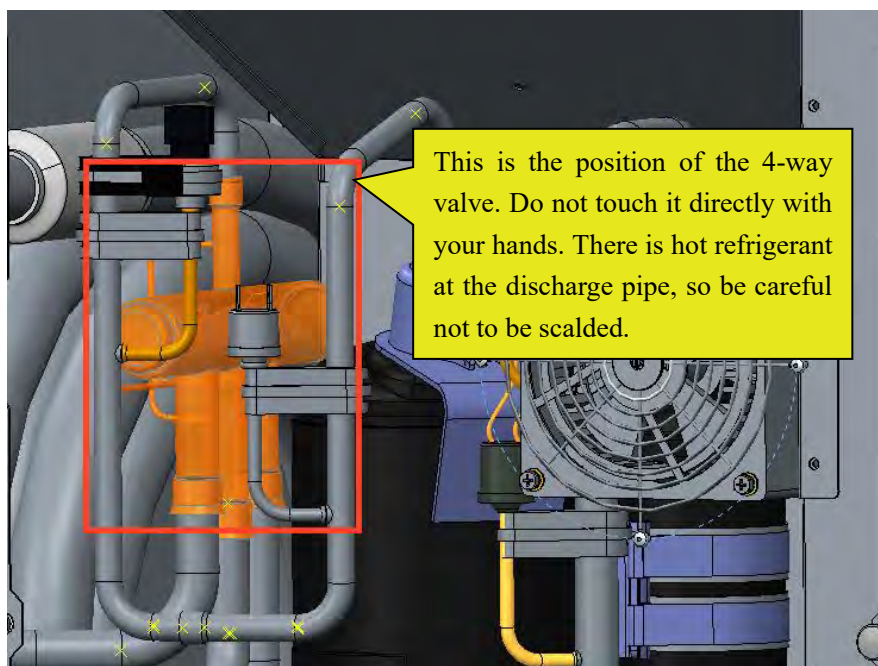

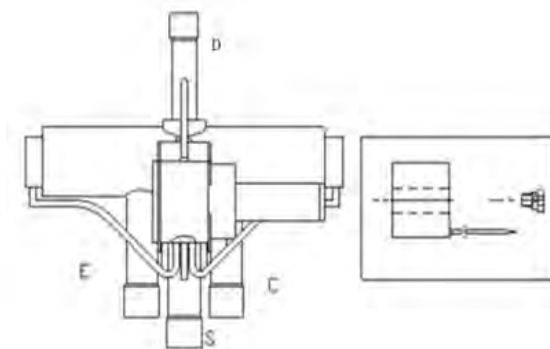

D- Connect to the discharge side

Caution! High temperature!

Labels on the 4-way valve:

D-connect to the discharge side; E-connect to the evaporator of A-Coil module;

S-connect to the inhalation side of the liquid separator; C-connect to the condenser;

When the system is in cooling mode, C-the pipeline is with high pressure and high temperature; E, S-the pipeline is with low pressure and low temperature;

When the system is in heating mode, E-the pipeline is with high pressure and high temperature; C, S-the pipeline is with low pressure and low temperature;

Because D is connected to the discharge side, it is with high pressure and high temperature regardless of the operating mode. When the unit is powered on, in oil return mode, the 4-way valve will produce some noise. Do not touch the pipes directly with your hands and be cautious of the hot temperature.

Step 4:

Check the drive board of compressor, i.e. the IPM module.

Please refer to the IPM checking method in the section of troubleshooting.

Check the drive board of compressor, i.e. the IPM module.

Please refer to the IPM checking method in the section of troubleshooting.

B. On condition that the unit cannot be started up

Step 1:

Cut off the power supply and detach the cover of the wiring box of the compressor. Check the wiring of the compressor.

Step 2:

Check the resistance between the wiring terminals (U, V, W) of compressor.

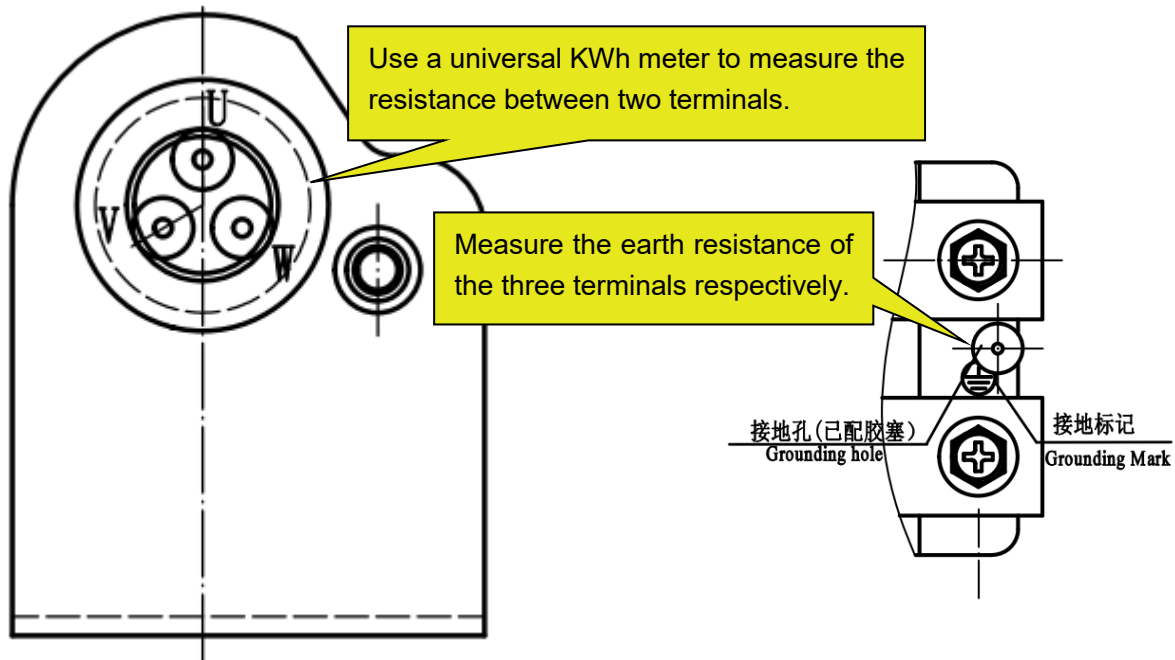

Refer to the following table for the resistance between any two terminals:

UV Winding resistance	VW Winding resistance	WU Winding resistance
$0.67 \pm 5\% \Omega$	$0.67 \pm 5\% \Omega$	$0.67 \pm 5\% \Omega$

Measure the earth resistance of each wiring terminal. The resistance should be above 10 megohm. If not, we can judge that the compressor is faulted inside.

Step 3:

On condition that the unit cannot be started up, we also need to check the solenoid valve assembly of the system, including the electronic expansion valve. The checking method is the same as instructed above.

Step 4:

Check whether the IPM module is normal. Please refer to the IPM checking method in the section of troubleshooting.

#### 5.4.1.2 Replacement of compressor

Step 1: Preparation

(1) Prepare the components for replacement

When carrying the old and new compressors, do not place the compressors horizontally or upside down. The angle of inclination should be within  $\pm 30^\circ$ . Make sure the lubricant inside the compressors will not flow from the oil balance mouth. The suction and discharge openings of the compressors must be sealed. If a rubber seal is missing, use adhesive tape to seal the opening. This is to prevent the compressor oil from contacting the air.



Make sure the rubber seals of the suction and discharge openings of the compressor are in good condition.



Make sure the electric box cover of the compressor is in good condition.

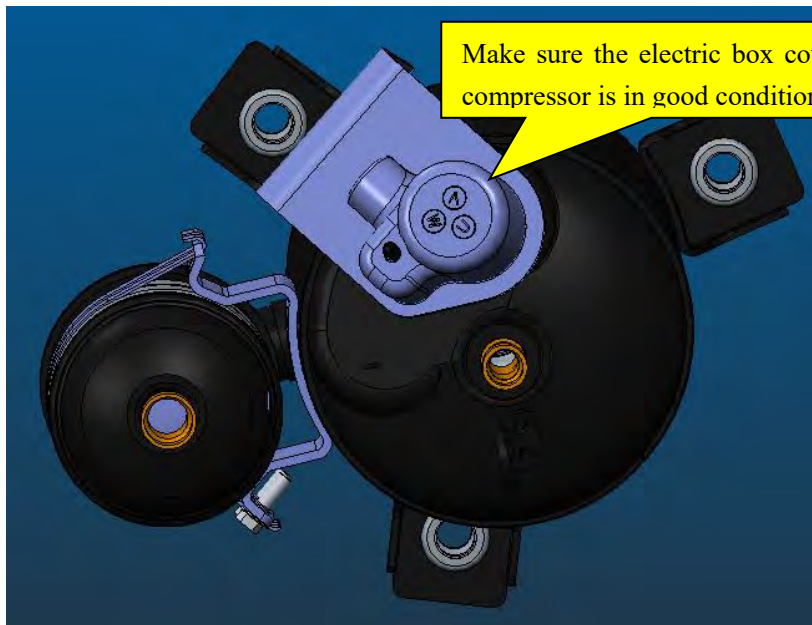



**NOTICE:** Make sure the lubricant is sealed inside the compressors.

(2) Prepare relevant tools

- 1) Prepare nitrogen. Please strictly follow the nitrogen welding standards during the welding process. Make sure there is sufficient nitrogen. The nitrogen pressure should be above 2.0MPa;
- 2) Prepare welding rods. Prepare some welding rods of common specifications and some special welding rods that contain more than 5% silver. They are used to weld the compressor. The suction and discharge openings of the compressor are all connected to copper-plated steel pipes, so we need to use special welding rods and solder;
- 3) Prepare applicable welding tools. Please evaluate how much oxygen and acetylene should be used according to the current welding condition. Try to avoid repeated welding.
- 4) Prepare a complete set of tools, including an internal hexagonal wrench, diagonal pliers, pincer pliers, nipper pliers, a universal meter, a pressure gauge, cross screwdriver, straight screwdriver, more than two wrenches, insulating tape and wire cables.

Step 2: Disconnect power

If the compressor needs to be replaced after judging as above, then switch off the compressor module and disconnect the power cable of the compressor module. Use insulating tape to wrap the power cable and put a notice board on the power switch to remind people to be cautious of electric shock.

Step 3: Neaten the electric components

When you detach the compressor wires and temperature sensors, mark them correspondingly for the convenience of reconnecting them.

Step 4: Discharge refrigerant

Discharge refrigerant from the system. Discharge simultaneously from the high pressure side and low pressure side. Do not discharge too fast (It should take more than 12h to completely discharge the refrigerant); otherwise, large quantity of lubricant will escape from the system together with the refrigerant.

Step 5: Detach the compressor

Check the condition of the damaged compressor, including its position and model.

If the information of the compressor is confirmed, check the oil quality.

(a) If the oil is clear and impurities-free, we consider that the oil of the system is not polluted. Meanwhile, if we confirm that the valves and pipes are also normal, then we can replace the compressor only. For the removal of compressor, please refer to the section: Removal of Major Components.

How to check oil quality?

- (1) After the compressor is detached, put it on a solid ground and shake it at an angle of 30~45° to ensure that the contaminant at the bottom of the compressor can be poured out.
- (2) Place the compressor at a position above the ground level and then pour out the oil from the air outlet of the compressor. Collect the oil in a transparent container. The amount of oil should be over 150ml.

**NOTE:**

- 1) The axial direction of the compressor should not slant at an angle larger than 20° to the horizontal direction.
  - 2) Prevent the compressor from falling.
  - 3) Put a transparent container (over 150ml in volume) under the discharge pipe to collect the compressor oil, thus we can see the oil quality.
- (3) Put the container of compressor lubricant in a bright location and see if there is impurity and discoloration. Sniff at the compressor lubricant. Normally, there is no pungent smell.
- (b) If the oil is contaminated, replace the compressor and the gas-liquid separator.

**NOTE:** Confirm whether the compressor needs to be replaced. The pipe mouths of the faulted compressor must be sealed by adhesive tape as soon as the compressor is detached. Make sure the compressor is well preserved for the ease of future analysis.

**Step 6: Clear the pipeline**

After confirming which parts of the system should be replaced, check the pipeline of the system. Blow through the main pipeline with nitrogen. After clearing the pipeline, if the components are not replaced immediately, seal the pipeline with adhesive tape to prevent the system from being contaminated by water and impurities in the air.

**Step 7: Replace the compressor**

For the removal of compressor, please refer to the section: Removal of Major Components.

**Step 8: Check the system for leaks**

- (1) First of all, check each welding point. Check whether the welding points are smooth and whether there is any obvious welding hole or other abnormal condition.
- (2) Next, fill high-pressure nitrogen into the system for leak detection. If it is only the compressor module that needs to be repaired and the A-Coil module is confirmed normal, then it's OK to charge high-pressure nitrogen into the compressor module only. Fill in the nitrogen simultaneously from the high pressure side and low pressure side. We recommend charging the nitrogen from the big and small valves at the same time. The pressure of nitrogen should be above 20kgf. Then use soapy water to

check for leaks. Check the welding points particularly.

- (3) Finally, retain the pressure of the system. Fill high-pressure nitrogen into the system and maintain the pressure above 25kgf. Close the big and small valves and keep the pressure of A-Coil module and compressor module for more than 12h. If the pressure remains unchanged, then start vacuum pumping; otherwise, check the system for leaks again.

Temperature should be considered when judging the pressure change. If temperature changes by 33.8°F (1°C), pressure will change by 0.01MPa or so.

For example, if temperature is 86°F (30°C) when nitrogen of 2.5MPa is charged, and temperature changes to 77°F (25°C) after 12h, we consider that the system is qualified if the pressure is found at 2.43MPa or above.

Step 9: Evacuate the system and charge refrigerant

Please refer to the section of maintenance: vacuum pumping and refrigerant charging.

Step 10: Connect electric components

Connect cables, compressor wires and the electric heating belt according to the signs marked before and the wiring diagram on the cover of the electric box.

## 5.4.2 How to replace the drive module of compressor

Step 1: First, make sure that power is cut off. Set the universal meter at the AC voltage and measure the voltage between AC-L and N. If each time the voltage is 0V (Errors may occur to the universal meter, sometimes the voltage may not be 0V), proceed with the next step and put a sign on the power switch that reads "Under maintenance, don't switch on".

Step 2: Measure the voltage between DC bus P and UN on the drive board of the compressor. Set the universal meter at the DC voltage and measure the voltage between P and UN as shown below. If the voltage is below 36V, proceed with the next step. In case that a universal meter is not available, disconnect power for 20min and then continue with the next step.

Step 3: Remove all the wires on the drive board of the compressor with insulation glove.

Step 4: Remove the screws on the drive board of the compressor. The screws are located in the white circles as shown above in the picture.

Step 5: Replace with a new compressor drive board. Before replacement, apply some silica gel on the IPM module, rectifier, MOSFET and diode.

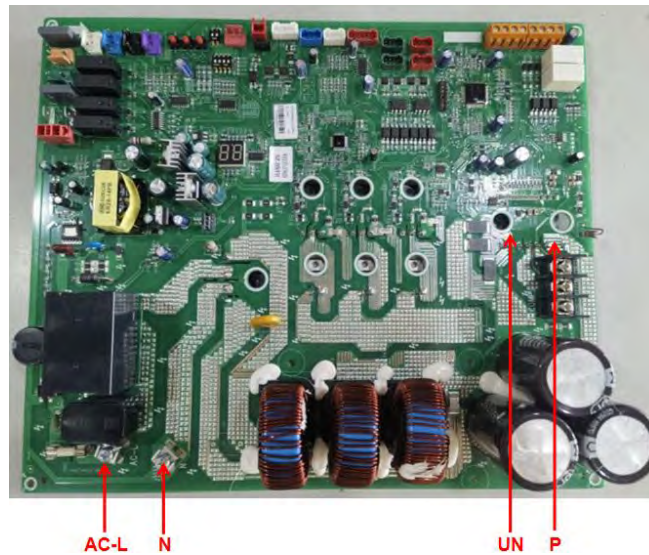

Step 6: Install the new compressor drive board. Fix the screws and connect the wires correctly.



## 5.5 Removal of Major Components

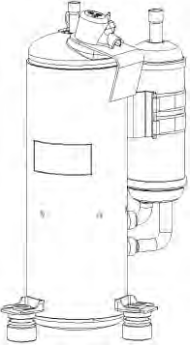
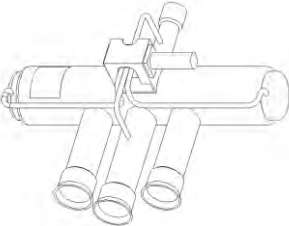
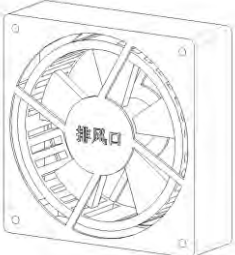

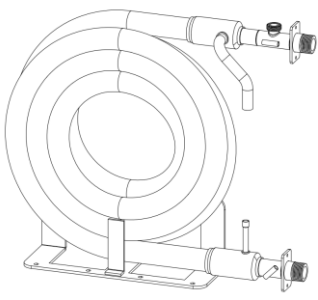
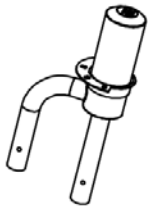
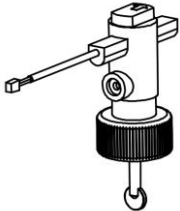
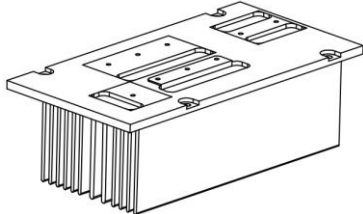
### 5.5.1 Major Components of Compressor Module

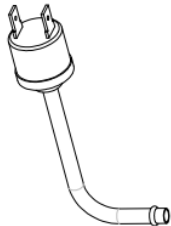
Picture	Name	Function
	Compressor	Through compression, the low pressure refrigerant occupies a less space. As its pressure and temperature both rise, it becomes high pressure and high temperature refrigerant. It is the power drive of the system.
	4-Way Valve	Usually used in heat pump systems to switch the flow direction of refrigerant in the system, in order to achieve the conversion of unit cooling and heating
	Fan	Introduce external air into the unit and cool the heating module on the main board through a heat sink to ensure normal operation of the main board.

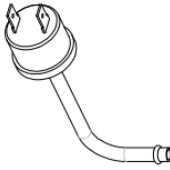
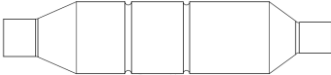
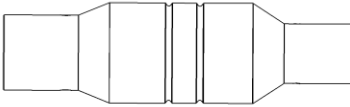
Picture	Name	Function
	Condenser	It is used to transfer partial heat of the hot flow to the cold flow so that the flow temperature can reach the specified index. It is an energy exchanging device.
	Electronic Expansion Valve	<p>The unit is equipped with two electronic expansion valves, located in the Compressor module and the A-Coil module, respectively, for the control of heating mode and cooling mode. The function of the electronic expansion valve is as follows:</p> <ol style="list-style-type: none"> <li>1. Throttling and depressurization of high-pressure liquid refrigerant to ensure the pressure difference between the condenser and evaporator.</li> <li>2. Adjust the refrigerant flow rate entering the evaporator to adapt to changes in the heat load of the evaporator and ensure stable operation of the refrigeration device.</li> </ol>
	Water-Flow Switch	Prevent freezing of the heat exchanger caused by a decrease in circulating water flow in the water system; Has anti freezing effect; When the system water volume decreased to its action setting value at that time, the stress on the target is reduced, resulting in the disconnection of the working path, the unit alarms and stops running.
	Radiator	The air blown in by the fan cools the heating module behind the main board to ensure that the main board works normally.
	High Pressure Sensor	Used to detect high pressure in the system, control the operation of the fan, and also have a system pressure protection function. When the pressure is too high, it will trigger relevant pressure protection actions.
	High Pressure Switch	Used for detecting the high-pressure pressure of the unit in ground water system. Detect the system high-pressure, in order to protect the unit from abnormal operation. When the system high-pressure is higher than the set value, an error will be displayed and the unit will not start or stop.

Picture	Name	Function
	Low Pressure Switch 2	Used for detecting the low-pressure pressure of the unit in ground loop system. Detect the system low-pressure, in order to protect the unit from abnormal operation. When the system low-pressure is lower than the set value, an error will be displayed and the unit will not start or stop.
	Low Pressure Switch 1	Used for detecting the low-pressure pressure of the unit in ground water system. Detect the system low-pressure, in order to protect the unit from abnormal operation. When the system low-pressure is lower than the set value, an error will be displayed and the unit will not start or stop.
	One Way Valve	The unit is equipped with two one-way valves, each connected in parallel in two electronic expansion valve flow paths, to ensure one-way flow of the refrigerant circuit.
	Filter	Located before and after the electronic expansion valve, it is used to filter impurities in the system and prevent blockage.

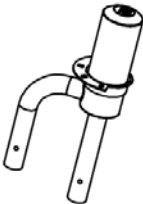
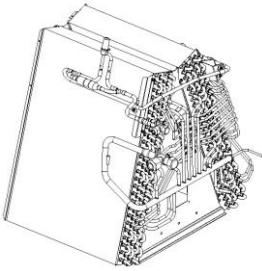
### 5.5.2 Major Components of A-Coil Module

Picture	Name	Function
	Electronic Expansion Valve	The unit is equipped with two electronic expansion valves, located in the Compressor module and the A-Coil module, respectively, for the control of heating mode and cooling mode. The function of the electronic expansion valve is as follows: <ol style="list-style-type: none"> <li>1. Throttling and depressurization of high-pressure liquid refrigerant to ensure the pressure difference between the condenser and evaporator.</li> <li>2. Adjust the refrigerant flow rate entering the evaporator to adapt to changes in the heat load of the evaporator and ensure stable operation of the refrigeration device.</li> </ol>
	Evaporator	Used for high-temperature and high-pressure gaseous refrigerant condensing and liquefying or low-temperature and low-pressure refrigerant evaporating; The condensation heat is carried away by the circulating air or the heat required for evaporation is provided by the indoor circulating air.
	One Way Valve	The unit is equipped with two one-way valves, each connected in parallel in two electronic expansion valve flow paths, to ensure one-way flow of the refrigerant circuit.

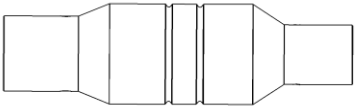
Picture	Name	Function
	Filter	Located before and after the electronic expansion valve, it is used to filter impurities in the system and prevent blockage.

### 5.5.3 Major Components of Blower Module

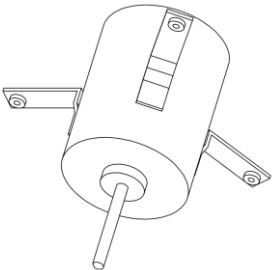
Picture	Name	Function
	Motor	The power drive of the fan. It enables the fan to run so as to provide smooth currents of air for forced convection and heat exchange of condenser and evaporator.



### 5.5.4 Removal of Compressor Module Major Components

Model: GCSHPM048IN / GCSHPM060IN

Removal of compressor

**NOTE: Before removing the compressor, make sure there is no refrigerant in the pipeline and power is cut off.**

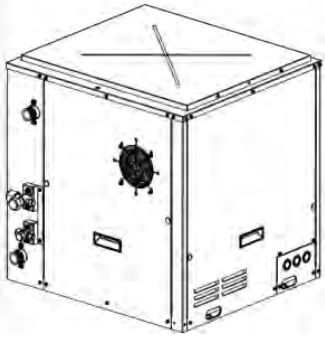
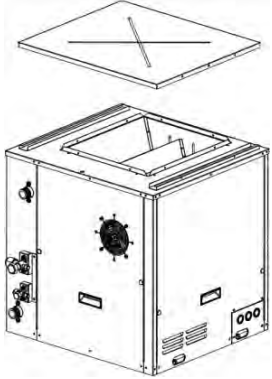
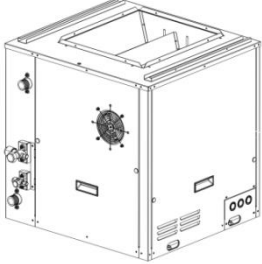
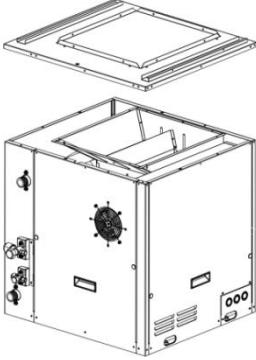
Step	Picture	Work instruction
<p>1. Dismantle the screws</p>		<ul style="list-style-type: none"> <li>● Dismantle the four screws that fix the lid (note: during the integral installation, the unit has already removed this lid, and this step can be ignored)</li> </ul>
<p>2. Remove the lid</p>		<ul style="list-style-type: none"> <li>● Remove the lid (note: during the integral installation, the unit has already removed this lid, and this step can be ignored)</li> </ul>
<p>3. Remove the screws that secure the top cover</p>		<ul style="list-style-type: none"> <li>● Remove the 23 screws that secure the top cover</li> </ul>
<p>4. Remove the cover</p>		<ul style="list-style-type: none"> <li>● Remove the cover</li> </ul>

Removal of compressor

**NOTE: Before removing the compressor, make sure there is no refrigerant in the pipeline and power is cut off.**

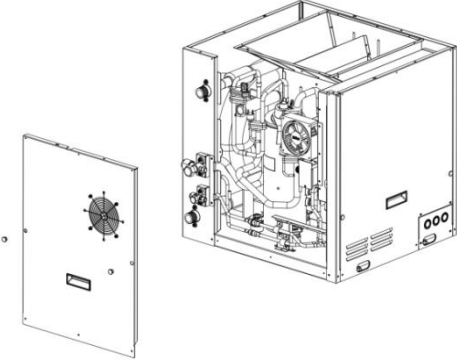
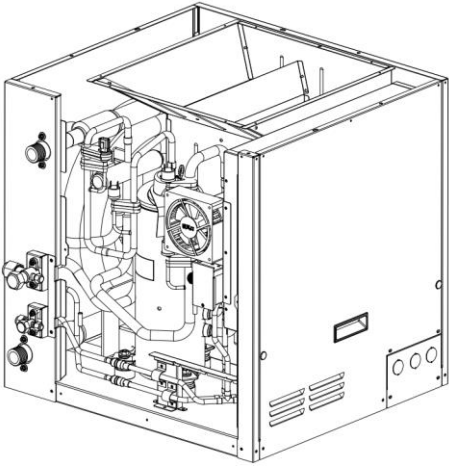
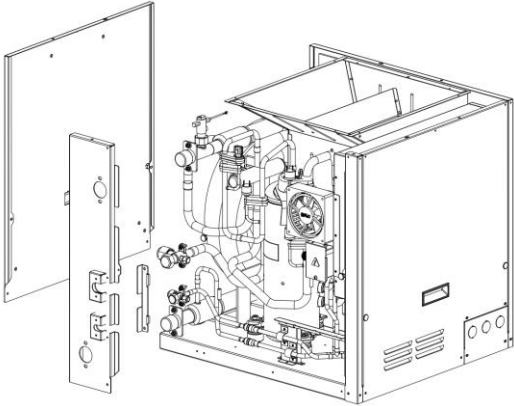
Step	Picture	Work instruction
<p>5. Remove the screws fixing the Panel (front)</p>		<ul style="list-style-type: none"> <li>● Pull out the two rubber plugs of the panel (front), and then remove the five screws fixing the Panel (front), and the four bolts fixing the Computer fan (note: there are also two screws under the rubber plug)</li> </ul>
<p>6. Remove the Panel (front)</p>		<ul style="list-style-type: none"> <li>● Remove the Panel (front)</li> </ul>
<p>7. Remove the screws fixing the Panel (left) and Panel (valve)</p>		<ul style="list-style-type: none"> <li>● Pull out the 2 rubber plugs on the Panel (left), and then remove the 5 screws that secure the Panel (left) (note: there are also two screws under the rubber plugs)</li> <li>● Dismantle the four screws that fix the size globe valve, the four bolts that fix the inlet and outlet water pipes, and the two screws that fix the Panel (valve)</li> </ul>
<p>8. Remove the Panel (left) and Panel (valve)</p>		<ul style="list-style-type: none"> <li>● Remove the panel (left)</li> <li>● Remove the panel (valve) (Note: Before removing the panel (valve), it is necessary to first remove the bracket next to the fixed bracket of the large and small shut-off valves, and fix it with two screws )</li> </ul>

Removal of compressor

**NOTE: Before removing the compressor, make sure there is no refrigerant in the pipeline and power is cut off.**

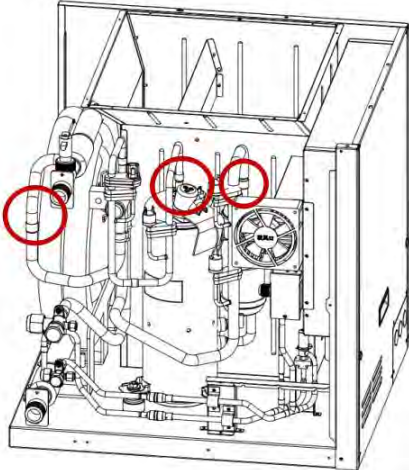
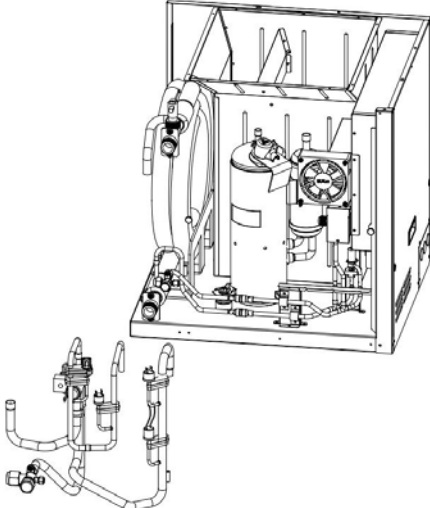
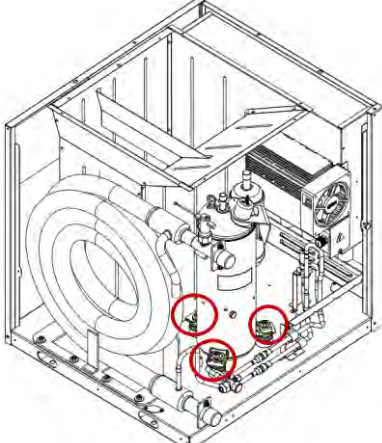
Step	Picture	Work instruction
<p>9. Weld out the interfaces</p>		<ul style="list-style-type: none"> <li>Weld out the interfaces marked in the diagram in preparation for removing the four way valve components and compressor</li> </ul>
<p>10. Remove the 4-way valve component</p>		<ul style="list-style-type: none"> <li>Remove the 4-way valve component</li> </ul>
<p>11. Dismantle the nut</p>		<ul style="list-style-type: none"> <li>Dismantle the three nuts securing the compressor foot pads (note: the two compressor foot pads in front of the compressor have been removed before installation and operation)</li> </ul>

Removal of compressor

**NOTE:** Before removing the compressor, make sure there is no refrigerant in the pipeline and power is cut off.

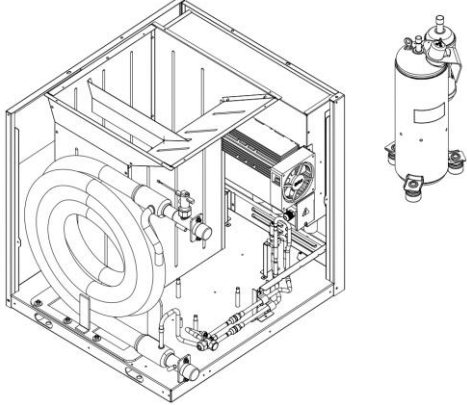
Step	Picture	Work instruction
12. Removing and replacing the compressor		<ul style="list-style-type: none"> <li>● Removing and replacing the compressor</li> </ul>

Model: GCSHPM048IN / GCSHPM060IN

Removal of 4-Way Valve

**NOTE:** Before removing the 4-Way valve, make sure there is no refrigerant in the pipeline and power is cut off.

The first ten steps are consistent with the first ten steps of replacing the compressor.

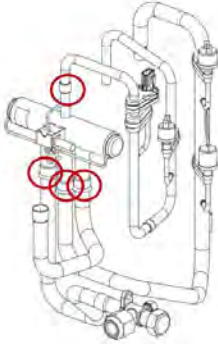
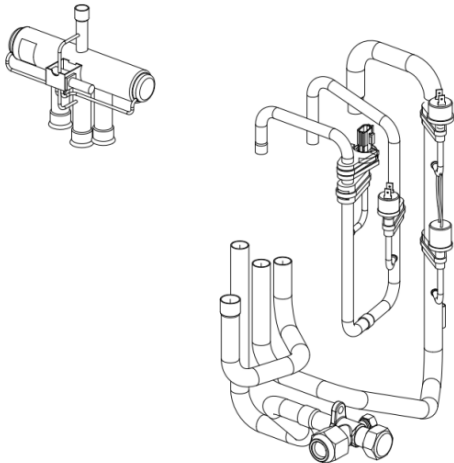
Step	Picture	Work instruction
1. Weld out the interface		<ul style="list-style-type: none"> <li>● Weld out the interface marked in the diagram in preparation for replacing the 4-way valve</li> </ul>
2. Remove and replace the four-way valve		<ul style="list-style-type: none"> <li>● Remove and replace the four-way valve</li> </ul>

Model: GCSHPM048IN / GCSHPM060IN

Removal of Co-axial Heat Exchanger

**NOTE:** Before removing the Co-Axial Heat Exchanger, make sure there is no refrigerant in the pipeline and power is cut off.

The first four steps are consistent with the first four steps of replacing the compressor

Step	Picture	Work instruction
------	---------	------------------

Removal of Co-axial Heat Exchanger

**NOTE:** Before removing the Co-Axial Heat Exchanger, make sure there is no refrigerant in the pipeline and power is cut off.  
The first four steps are consistent with the first four steps of replacing the compressor

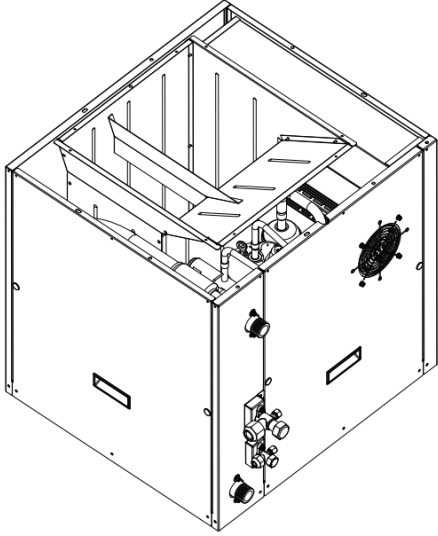
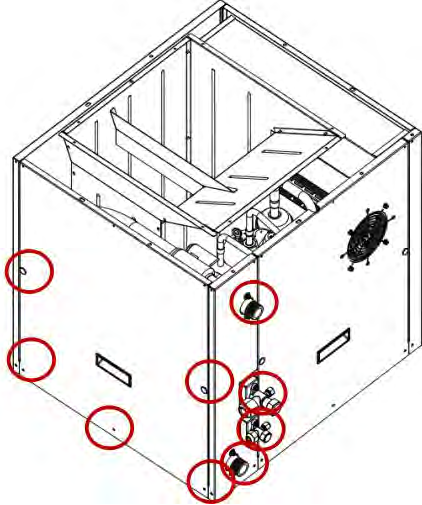
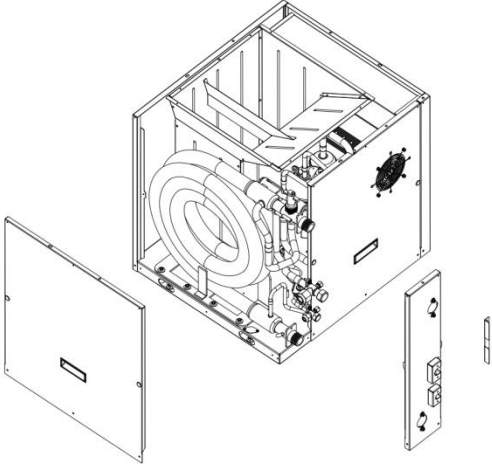
Step	Picture	Work instruction
<p>1. Preparation for replacing the co-axial heat exchanger</p>		<ul style="list-style-type: none"> <li>● The first four steps are consistent with the first four steps of replacing the compressor</li> </ul>
<p>2. Remove the screws fixing the Panel (left) and Panel (valve)</p>		<ul style="list-style-type: none"> <li>● Pull out the 2 rubber plugs on the Panel (left), and then remove the 5 screws that secure the Panel (left) (note: there are also two screws under the rubber plugs)</li> <li>● Dismantle the four screws that fix the size globe valve, the four bolts that fix the inlet and outlet water pipes, and the two screws that fix the Panel (valve)</li> </ul>
<p>3. Remove the Panel (left) and Panel (valve)</p>		<ul style="list-style-type: none"> <li>● Remove the Panel (left)</li> <li>● Remove the Panel (valve) (Note: Before removing the Panel (valve), it is necessary to first remove the bracket next to the fixed bracket of the large and small shut-off valves, and fix it with two screws at the top and bottom)</li> </ul>



## Removal of Co-axial Heat Exchanger

**NOTE:** Before removing the Co-Axial Heat Exchanger, make sure there is no refrigerant in the pipeline and power is cut off.  
The first four steps are consistent with the first four steps of replacing the compressor

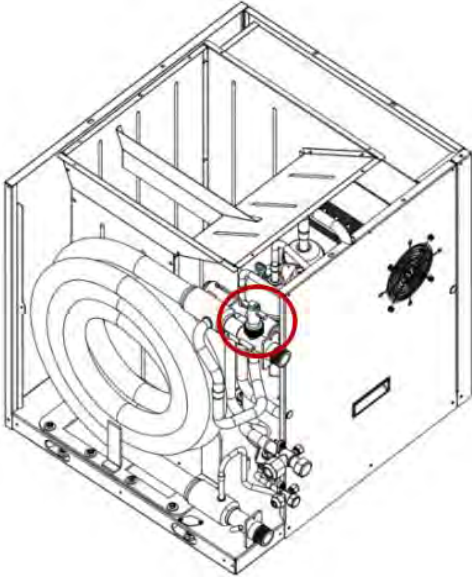
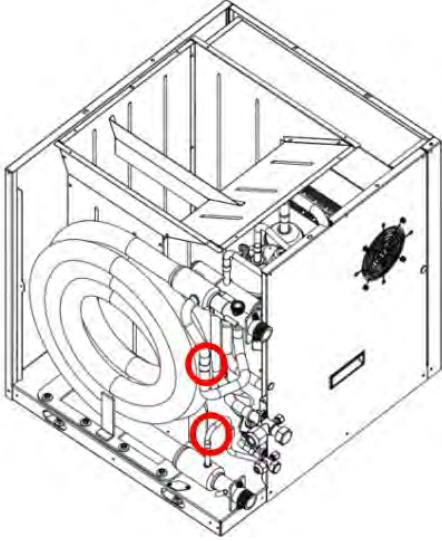
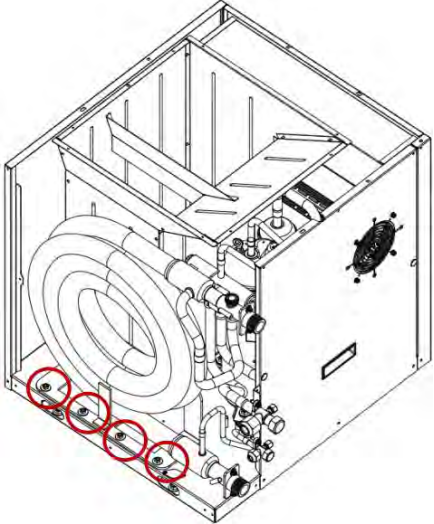
Step	Picture	Work instruction
<p>4. Remove the water flow switch and inlet/outlet water temperature sensor</p>		<ul style="list-style-type: none"> <li>● Remove the water flow switch and inlet/outlet water temperature sensor</li> </ul>
<p>5. Weld out the interfaces</p>		<ul style="list-style-type: none"> <li>● Weld out the interfaces marked in the diagram in preparation for removing the co-axial heat exchanger</li> </ul>
<p>6. Dismantle the nuts</p>		<ul style="list-style-type: none"> <li>● Dismantle the four nuts securing the co-axial heat exchanger</li> </ul>

Removal of Co-axial Heat Exchanger

**NOTE:** Before removing the Co-Axial Heat Exchanger, make sure there is no refrigerant in the pipeline and power is cut off.  
The first four steps are consistent with the first four steps of replacing the compressor

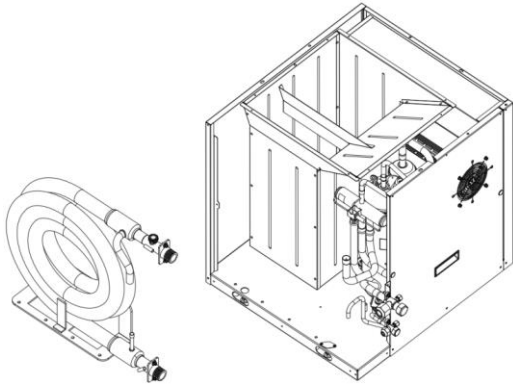
Step	Picture	Work instruction
<p>7. Removing and replacing the co-axial heat exchanger.</p>		<ul style="list-style-type: none"> <li>● Removing and replacing the co-axial heat exchanger</li> </ul>

Model: GCSHPM048IN / GCSHPM060IN

Removal of pressure sensor/pressure switch

**NOTE:** Before removing the pressure sensor/pressure switch, make sure there is no refrigerant in the pipeline and power is cut off.  
The first ten steps are consistent with the first ten steps of replacing the compressor

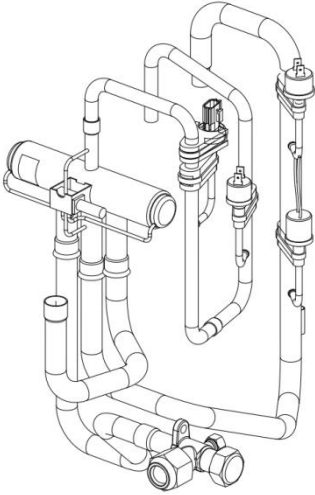
Step	Picture	Work instruction
<p>1. Remove the 4-way valve component</p>		<ul style="list-style-type: none"> <li>● The first ten steps are consistent with the first ten steps of compressor replacement</li> </ul>

Removal of pressure sensor/pressure switch

**NOTE:** Before removing the pressure sensor/pressure switch, make sure there is no refrigerant in the pipeline and power is cut off.  
The first ten steps are consistent with the first ten steps of replacing the compressor

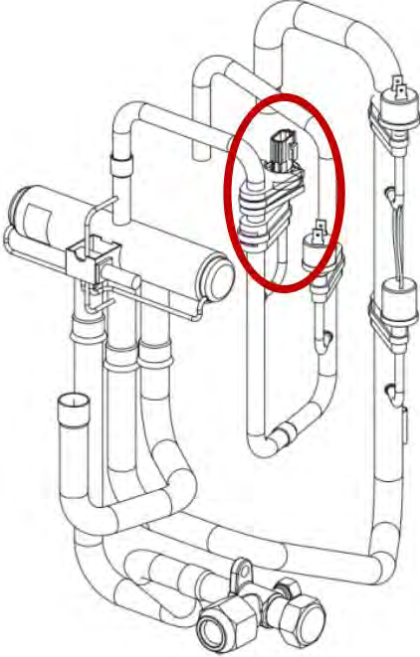
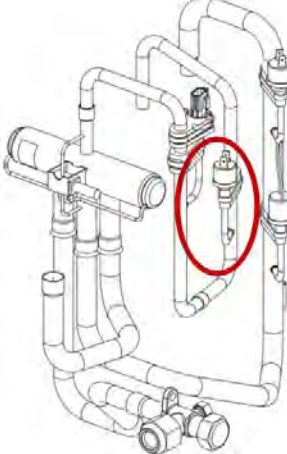
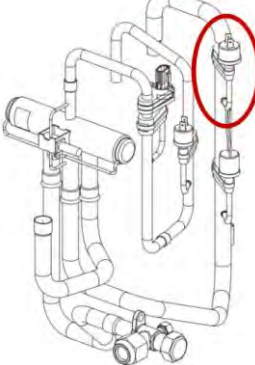
Step	Picture	Work instruction
<p>2. Remove and replace the high pressure sensor</p>		<ul style="list-style-type: none"> <li>● Remove the pipe fixing block and wire tie for fixing the pressure sensor</li> <li>● Welding off the pressure sensor interface</li> <li>● Remove and replace the high pressure sensor</li> </ul>
<p>3. Remove and replace the high pressure switch</p>		<ul style="list-style-type: none"> <li>● Remove the pipe fixing block and wire tie of the fixed high pressure switch</li> <li>● Weld out the interface of the high pressure switch</li> <li>● Remove and replace the high pressure switch</li> </ul>
<p>4. Remove and replace the pressure switch low pressure switch 2</p>		<ul style="list-style-type: none"> <li>● Remove the pipe fixing block and wire tie of the fixed pressure low pressure switch 2</li> <li>● Weld off the interface of the low pressure switch 2</li> <li>● Remove the pressure switch low pressure switch 2 and replace it</li> </ul>



Removal of pressure sensor/pressure switch

**NOTE:** Before removing the pressure sensor/pressure switch, make sure there is no refrigerant in the pipeline and power is cut off.  
The first ten steps are consistent with the first ten steps of replacing the compressor

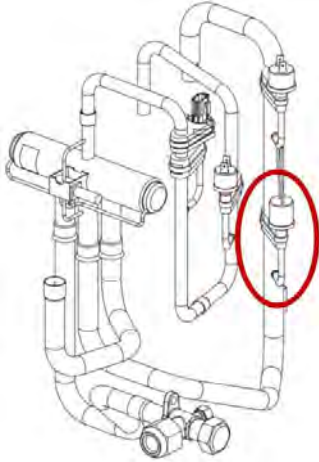
Step	Picture	Work instruction
<p>5. Remove and replace the low pressure switch 1</p>		<ul style="list-style-type: none"> <li>● Remove the pipe fixing block and wire tie that fix the low pressure switch 1</li> <li>● Weld off the interface of the low pressure switch 1</li> <li>● Remove and replace the low pressure switch 1</li> </ul>

Model: GCSHPM048IN / GCSHPM060IN

Removal of Electronic Expansion Valve

**NOTE:** Before removing the Electronic Expansion Valve, make sure there is no refrigerant in the pipeline and power is cut off.  
The first six steps are consistent with the first six steps of replacing the compressor

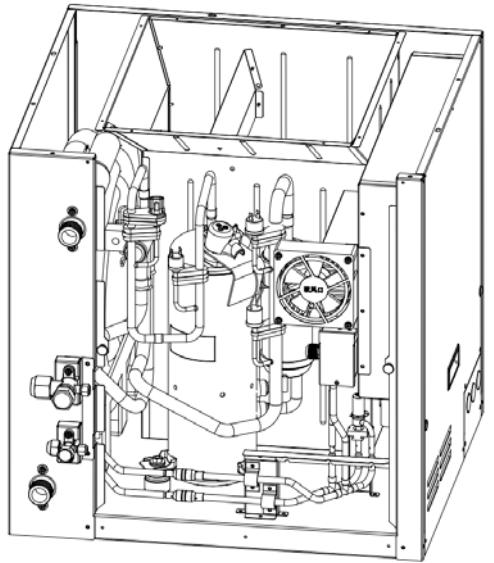
Step	Picture	Work instruction
<p>1. Preparation for replacing the electronic expansion valve</p>		<ul style="list-style-type: none"> <li>● The first six steps are consistent with the first six steps of compressor replacement</li> </ul>

Removal of Electronic Expansion Valve

**NOTE:** Before removing the Electronic Expansion Valve, make sure there is no refrigerant in the pipeline and power is cut off.  
The first six steps are consistent with the first six steps of replacing the compressor

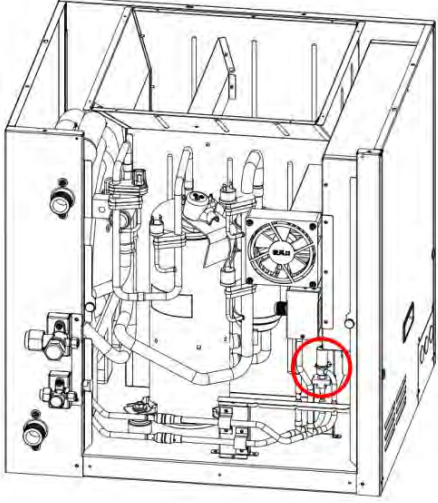
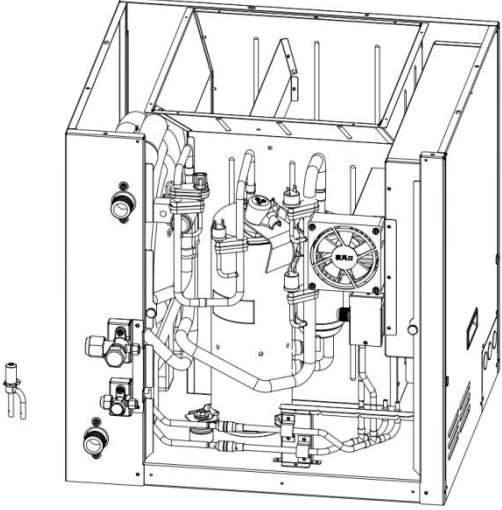
Step	Picture	Work instruction
<p>2. Remove the fixed bracket of the electronic expansion valve</p>		<ul style="list-style-type: none"> <li>● Firstly, remove the fixed bracket of the electronic expansion valve</li> <li>● Remove the electronic expansion valve fixing block</li> <li>● Remove the welding interface</li> </ul>
<p>3. Remove and replace the electronic expansion valve</p>		<ul style="list-style-type: none"> <li>● Remove and replace the electronic expansion valve</li> </ul>

Model: GCSHPM048IN / GCSHPM060IN

Removal of Fan

**NOTE:** Before removing the Fan, make sure power is cut off.  
The first six steps are consistent with the first six steps of replacing the compressor

Step	Picture	Work instruction
------	---------	------------------

Removal of Fan

**NOTE:** Before removing the Fan, make sure power is cut off.

The first six steps are consistent with the first six steps of replacing the compressor

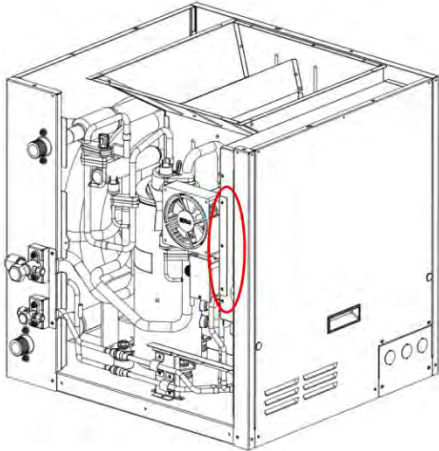
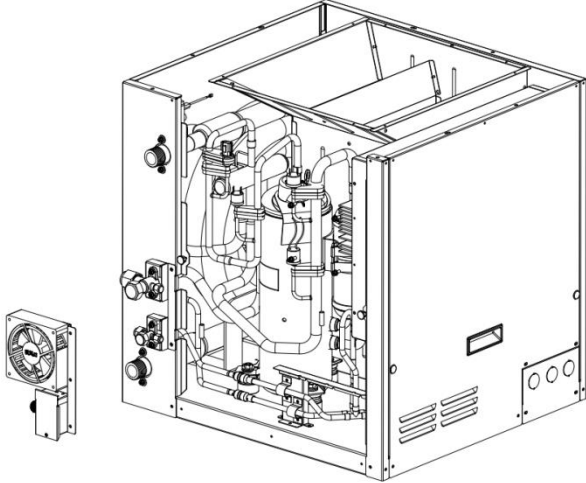
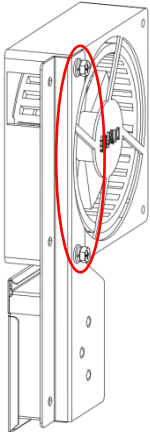
Step	Picture	Work instruction
<p>1. Preparation for replacing the fan</p>		<ul style="list-style-type: none"> <li>● The first six steps are consistent with the first six steps of compressor replacement.</li> <li>● Remove two screws fixing the fan.</li> </ul>
<p>2. Remove the fan component</p>		<ul style="list-style-type: none"> <li>● Remove the fan component</li> </ul>
<p>3. Remove the screws fixing the fan</p>		<ul style="list-style-type: none"> <li>● Remove two screws fixing the fan</li> </ul>

Removal of Fan

**NOTE:** Before removing the Fan, make sure power is cut off.

The first six steps are consistent with the first six steps of replacing the compressor

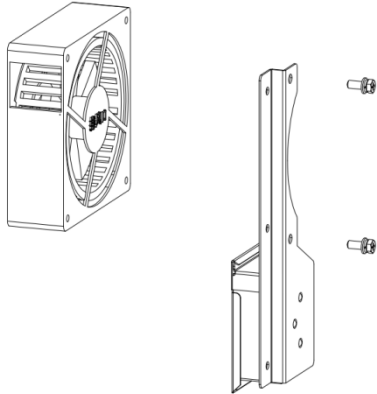
Step	Picture	Work instruction
4. Removing the fan		<ul style="list-style-type: none"> <li>● Removing the fan and replacing</li> </ul>

Model: GCSHPM048IN / GCSHPM060IN

Removal of Radiator

**NOTE:** Before removing the Radiator, make sure power is cut off.

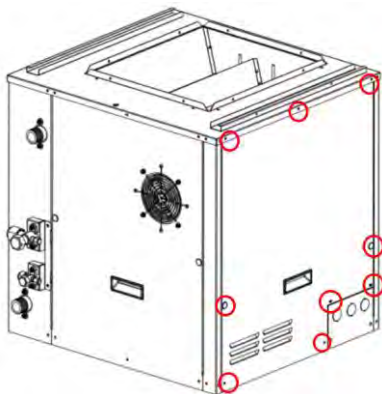
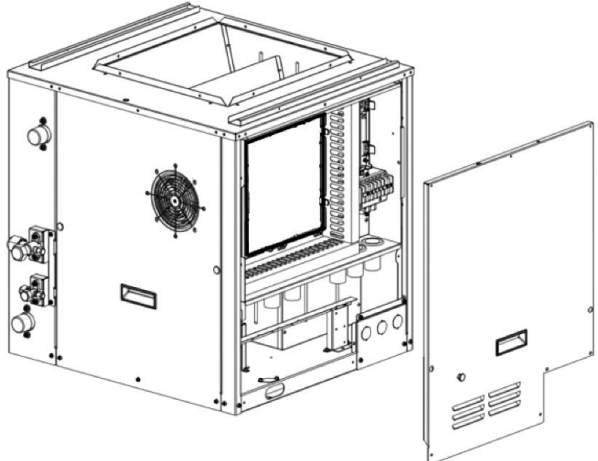
Step	Picture	Work instruction
1. Removing the nine screws fixing the Panel (right)		<ul style="list-style-type: none"> <li>● Pulling out the two rubber plugs of the Panel (right), and then removing the nine screws fixing the Panel (right) (note: there are also two screws under the rubber plug)</li> </ul>
2. Remove the right side panel		<ul style="list-style-type: none"> <li>● Remove the right side panel</li> </ul>

Removal of Radiator

**NOTE:** Before removing the Radiator, make sure power is cut off.

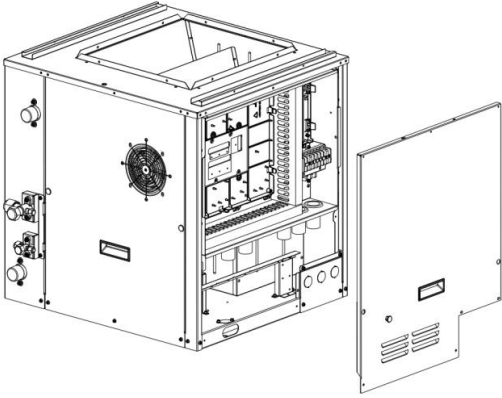
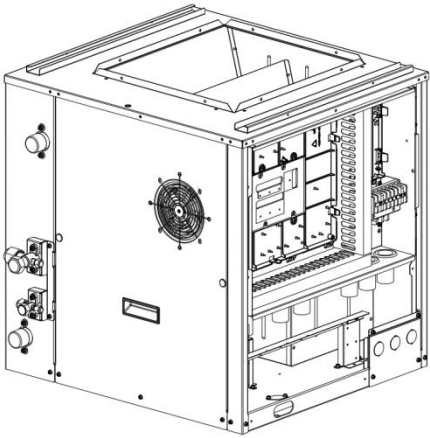
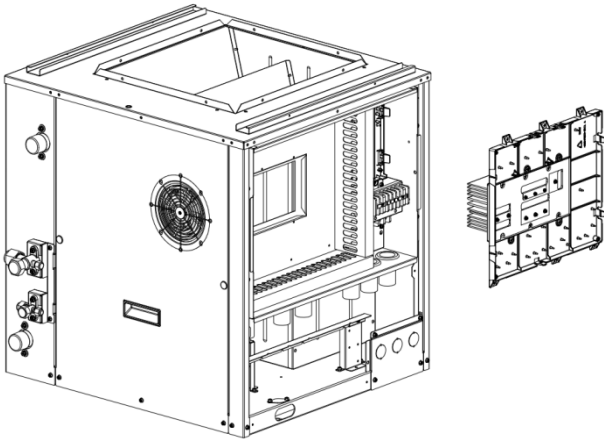
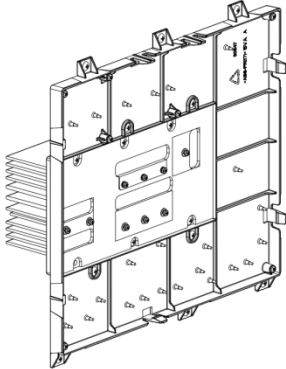
Step	Picture	Work instruction
<p>3. Remove the mainboard</p>		<ul style="list-style-type: none"> <li>● Remove 16 screws that secure the mainboard and Remove the mainboard</li> </ul>
<p>4. Remove the screws</p>		<ul style="list-style-type: none"> <li>● Remove the screws that secure the injection molded parts of the main board (a total of 4)</li> </ul>
<p>5. Remove the electrical retaining plate</p>		<ul style="list-style-type: none"> <li>● Remove the electrical retaining plate</li> </ul>
<p>6. Remove the main board</p>		<ul style="list-style-type: none"> <li>● Remove all the screws (totaling 7) that secure the main board and remove the main board</li> </ul>

Removal of Radiator

**NOTE:** Before removing the Radiator, make sure power is cut off.

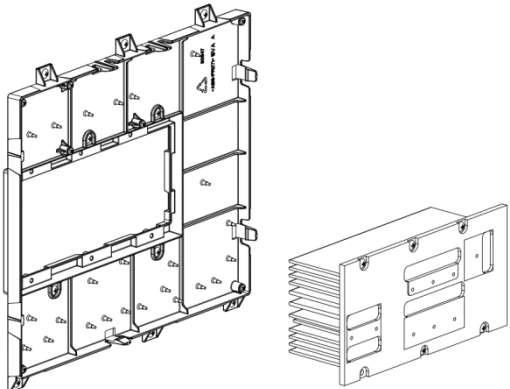
Step	Picture	Work instruction
7. Replace the radiator		<ul style="list-style-type: none"> <li>● Remove all the screws (6 in total) that secure the radiator and replace it.</li> </ul>

Model: GCSHPM048IN / GCSHPM060IN

Removal of Water-Flow Switch

**NOTE:** Before removing the Water-Flow Switch, make sure power is cut off.

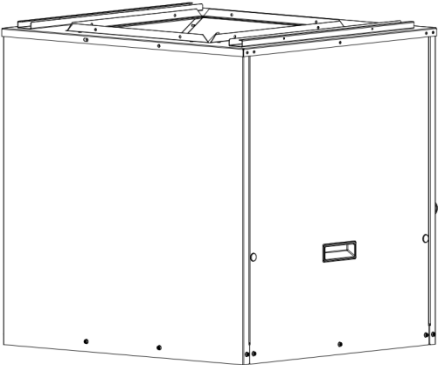
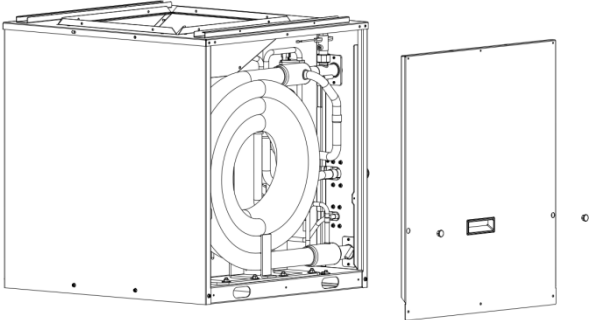
Step	Picture	Work instruction
1. Remove the screws		<ul style="list-style-type: none"> <li>● Pull out the 2 rubber plugs on the Panel (left), and then remove the 8 screws that secure the Panel (left) (note: there are also two screws under the rubber plugs)</li> </ul>
2. Remove the left side panel		<ul style="list-style-type: none"> <li>● Remove the left side panel</li> </ul>

Removal of Water-Flow Switch		
<b>NOTE:</b> Before removing the Water-Flow Switch, make sure power is cut off.		
Step	Picture	Work instruction
3. Replace the water-flow switch.		<ul style="list-style-type: none"> <li>● Loosen the nut that fixes the water flow switch to remove it and replace it with the inlet and outlet water temperature sensor</li> </ul>

### 5.5.5 Removal of A-Coil Module Major Components

Model: GCSCAM048GN / GCSCA060GN

Removal of Evaporator		
<b>NOTE:</b> Before removing the Evaporator, make sure power is cut off.		
Step	Picture	Work instruction
1. Remove the screws		<ul style="list-style-type: none"> <li>● Remove the nine screws from the cover assembly 3.</li> </ul>



Removal of Evaporator

**NOTE: Before removing the Evaporator, make sure power is cut off.**

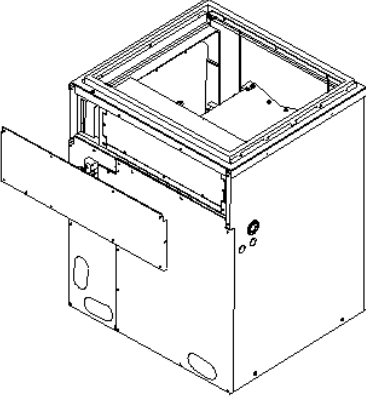
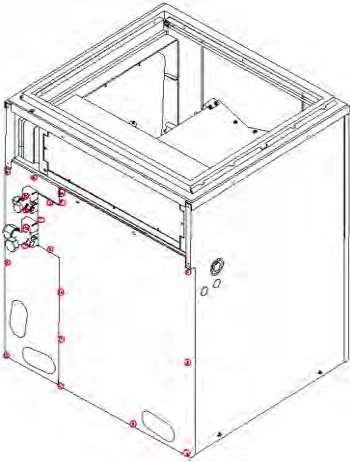
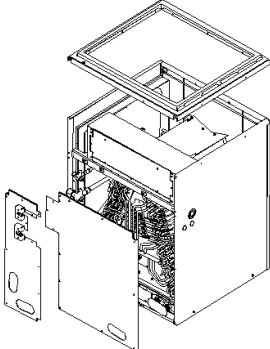
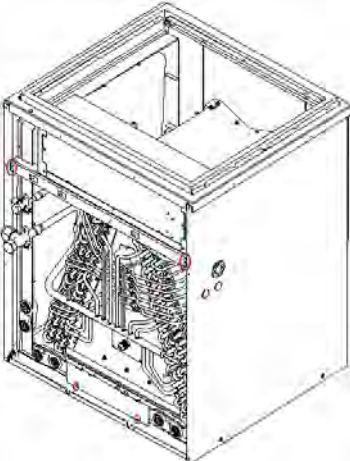
Step	Picture	Work instruction
2. Remove cover plate		<ul style="list-style-type: none"> <li>● Remove cover plate assembly 3.</li> </ul>
3. Remove the screws		<ul style="list-style-type: none"> <li>● Remove all screws from the top cover and cover plate components (1 and 2). Note that the screws securing the valve also need to be removed.</li> </ul>
4. Remove the top cover and cover plate		<ul style="list-style-type: none"> <li>● Remove the top cover and cover plate components (1, 2).</li> </ul>
5. Remove the screws		<ul style="list-style-type: none"> <li>● Remove the screws that secure the bracket of the electrical box and the fixing plate of the drain pan. Note that there are also fixing screws between the bracket of the electrical box and the evaporator.</li> </ul>



## Removal of Evaporator

**NOTE: Before removing the Evaporator, make sure power is cut off.**

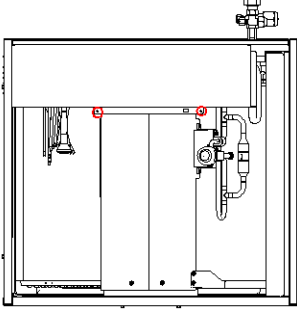
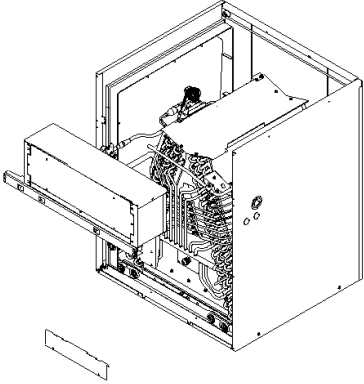
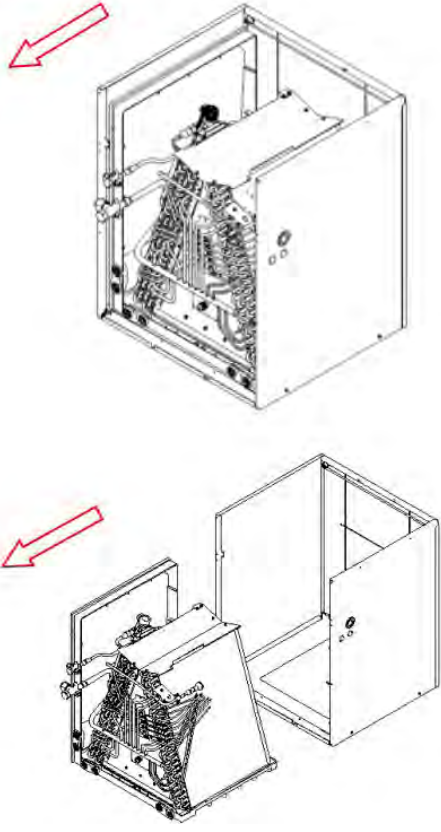
Step	Picture	Work instruction
6. Remove the screws		<ul style="list-style-type: none"> <li>● Remove the fixing screws between the electrical box bracket and the evaporator.</li> </ul>
7. Remove the electrical box bracket and the drain pan fixing plate.		<ul style="list-style-type: none"> <li>● Remove the electrical box bracket and the drain pan fixing plate.</li> </ul>
8. Pull the evaporator components out		<ul style="list-style-type: none"> <li>● Pull the evaporator components out in the direction shown.</li> </ul>

Removal of Evaporator

**NOTE: Before removing the Evaporator, make sure power is cut off.**

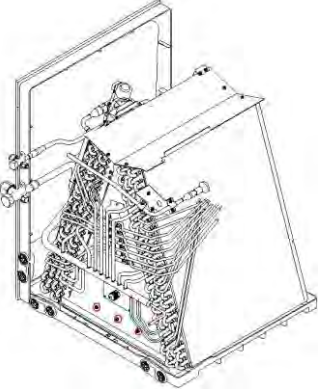
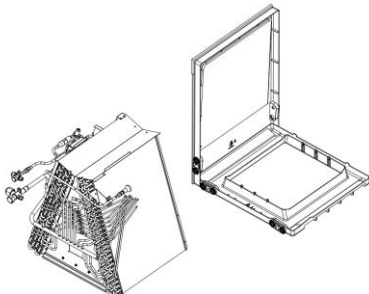
Step	Picture	Work instruction
9. Remove the screws		<ul style="list-style-type: none"> <li>● Remove the fixing screws of the evaporator and the drain pan, with 3 screws in the front and 3 screws in the back, totaling 6 screws.</li> </ul>
10. Remove the evaporator.		<ul style="list-style-type: none"> <li>● Remove the evaporator.</li> </ul>

Model: GCSCAM048GN / GCSCA060GN

Removal of Main Board

**NOTE: Before removing the Main Board, make sure power is cut off.**

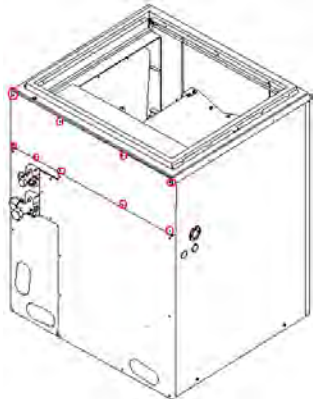
Step	Picture	Work instruction
1. Remove the screws		<ul style="list-style-type: none"> <li>● Remove the nine screws from the cover assembly 3.</li> </ul>

## Removal of Main Board

**NOTE: Before removing the Main Board, make sure power is cut off.**

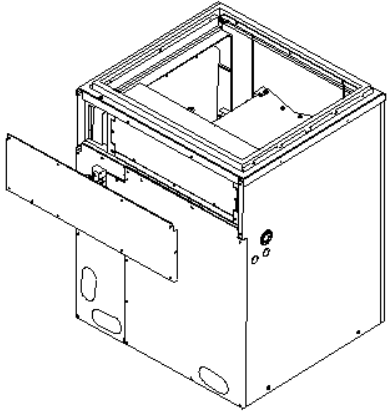
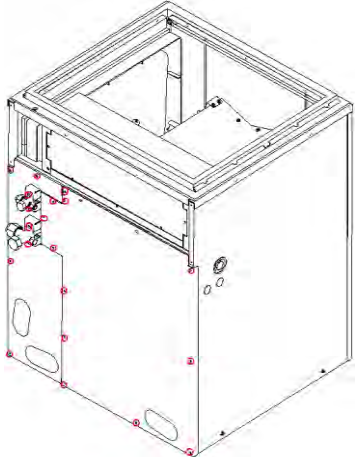
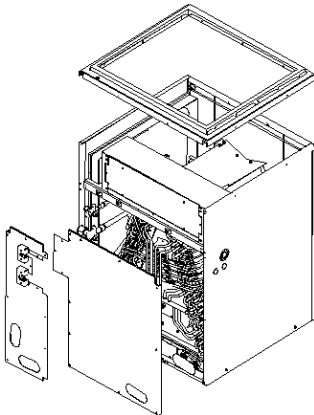
Step	Picture	Work instruction
2. Remove cover plate		<ul style="list-style-type: none"> <li>● Remove cover plate assembly 3.</li> </ul>
3. Remove the screws		<ul style="list-style-type: none"> <li>● Remove all screws from the top cover and cover plate components (1 and 2). Note that the screws securing the valve also need to be removed.</li> </ul>
4. Remove the top cover and cover plate		<ul style="list-style-type: none"> <li>● Remove the top cover and cover plate components (1, 2).</li> </ul>

Removal of Main Board

**NOTE: Before removing the Main Board, make sure power is cut off.**

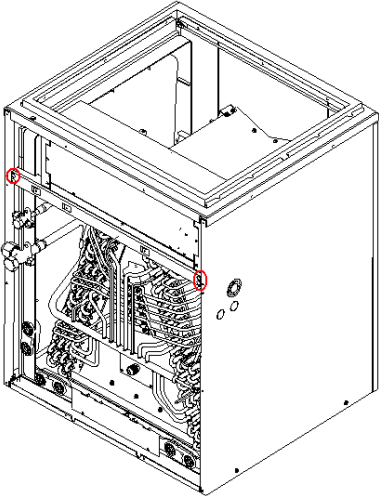
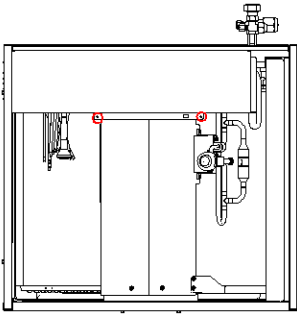
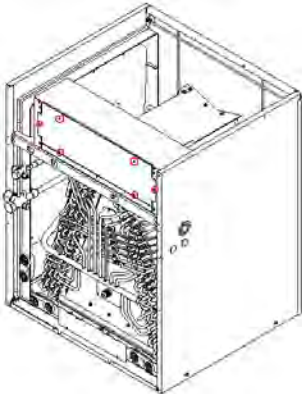
Step	Picture	Work instruction
<p>5. Remove the screws</p>		<ul style="list-style-type: none"> <li>● Remove the screws that secure the electrical box bracket. Note that there are also fixing screws between the electrical box bracket and the evaporator.</li> </ul>
<p>6. Remove the screws</p>		<ul style="list-style-type: none"> <li>● Remove the fixing screws between the electrical box bracket and the evaporator.</li> </ul>
<p>7. Remove the screws</p>		<ul style="list-style-type: none"> <li>● Remove the six screws from the electrical box cover.</li> </ul>

Removal of Main Board

**NOTE: Before removing the Main Board, make sure power is cut off.**

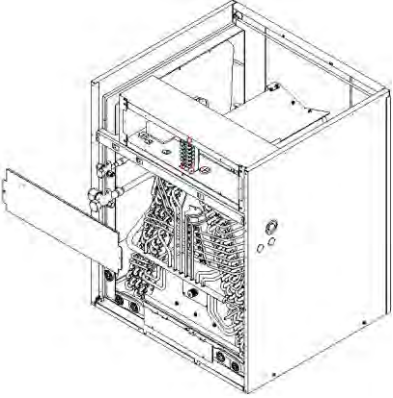
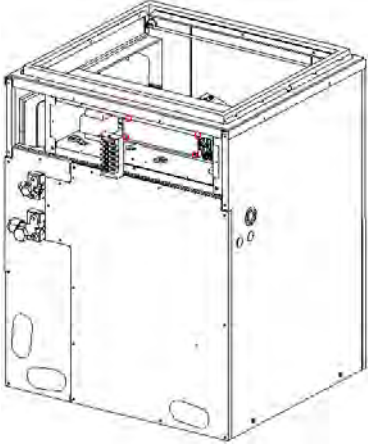
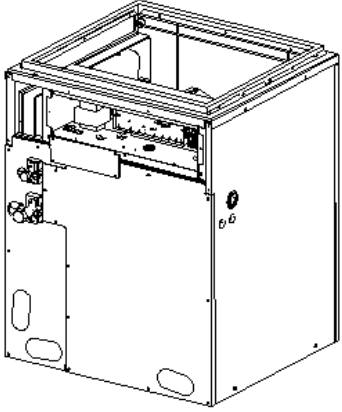
Step	Picture	Work instruction
8.Remove the electrical box cover		<ul style="list-style-type: none"> <li>● Remove the electrical box cover and remove the three screws of the bracket assembly. Remove all wiring from the wiring board and main board.</li> </ul>
9.Remove the bracket assembly		<ul style="list-style-type: none"> <li>● Remove the bracket assembly and wiring board (6-position), and remove the four screws that secure the main board.</li> </ul>
10.Remove the main board.		<ul style="list-style-type: none"> <li>● Remove the main board.</li> </ul>

Model: GCSCAM048GN / GCSCA060GN

Removal of Drain Pan

**NOTE: Before removing the Drain Pan, make sure power is cut off.**

Step	Picture	Work instruction
------	---------	------------------

Removal of Drain Pan

**NOTE: Before removing the Drain Pan, make sure power is cut off.**

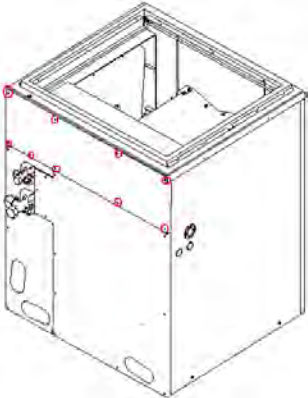
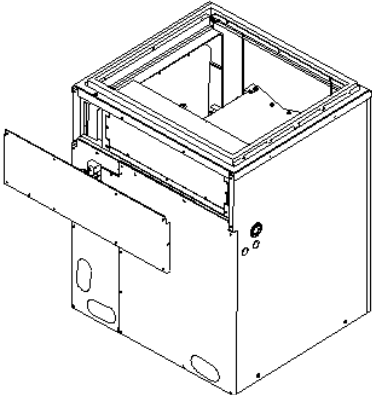
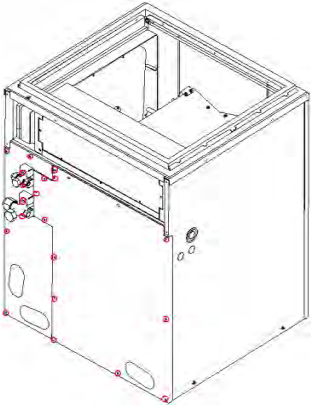
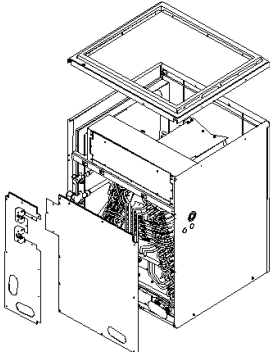
Step	Picture	Work instruction
1. Remove the screws		<ul style="list-style-type: none"> <li>● Remove the nine screws from the cover assembly 3.</li> </ul>
2. Remove cover plate		<ul style="list-style-type: none"> <li>● Remove cover plate assembly 3.</li> </ul>
3. Remove the screws		<ul style="list-style-type: none"> <li>● Remove all screws from the top cover and cover plate components (1 and 2). Note that the screws securing the valve also need to be removed.</li> </ul>
4. Remove the top cover and cover plate		<ul style="list-style-type: none"> <li>● Remove the top cover and cover plate components (1, 2).</li> </ul>

Removal of Drain Pan

**NOTE: Before removing the Drain Pan, make sure power is cut off.**

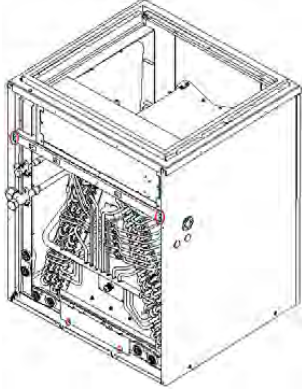
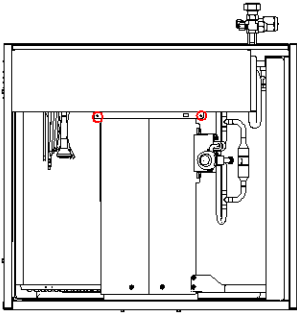
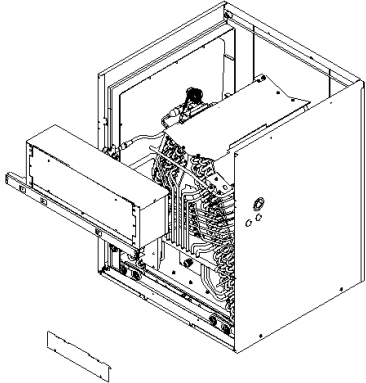
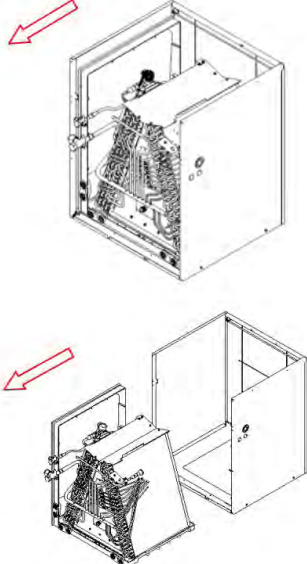
Step	Picture	Work instruction
<p>5. Remove the screws</p>		<ul style="list-style-type: none"> <li>● Remove the screws that secure the bracket of the electrical box and the fixing plate of the drain pan. Note that there are also fixing screws between the bracket of the electrical box and the evaporator.</li> </ul>
<p>6. Remove the screws</p>		<ul style="list-style-type: none"> <li>● Remove the fixing screws between the electrical box bracket and the evaporator.</li> </ul>
<p>7. Remove the electrical box bracket and the drain pan fixing plate.</p>		<ul style="list-style-type: none"> <li>● Remove the electrical box bracket and the drain pan fixing plate.</li> </ul>
<p>8. Pull the evaporator components out</p>		<ul style="list-style-type: none"> <li>● Pull the evaporator components out in the direction shown.</li> </ul>

Removal of Drain Pan

**NOTE: Before removing the Drain Pan, make sure power is cut off.**

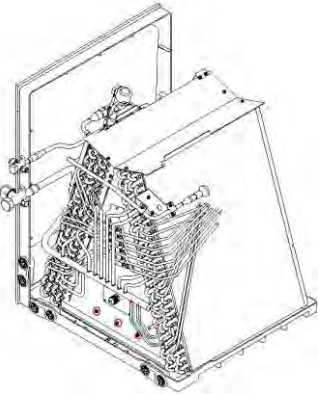
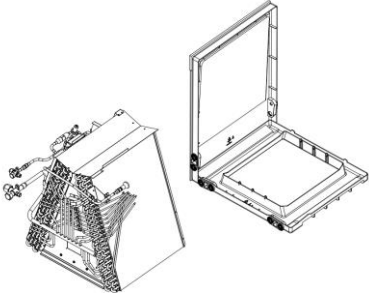
Step	Picture	Work instruction
9. Remove the screws		<ul style="list-style-type: none"> <li>● Remove the fixing screws of the evaporator and the drain pan, with 3 screws in the front and 3 screws in the back, totaling 6 screws.</li> </ul>
10 Remove the evaporator.		<ul style="list-style-type: none"> <li>● Remove the evaporator and replace the drain pan.</li> </ul>

Model: GCSCAM048GN / GCSCA060GN

Removal of Electronic Expansion Valve

**NOTE: Before removing the Electronic Expansion Valve, make sure power is cut off.**

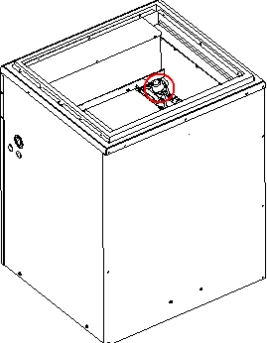
Step	Picture	Work instruction
1. Rotate the electronic expansion valve		<ul style="list-style-type: none"> <li>● Rotate the electronic expansion valve to make it detachable.</li> </ul>

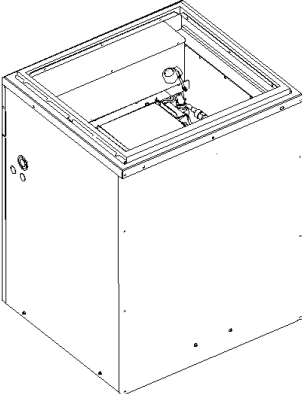

<p>2.Remove and replace the electronic expansion valve.</p>		<p>● Remove and replace the electronic expansion valve.</p>
---	---	---

### 5.5.3 Removal of Blower Module Major Components

Model: GCSBLM013 / GCSBLM014

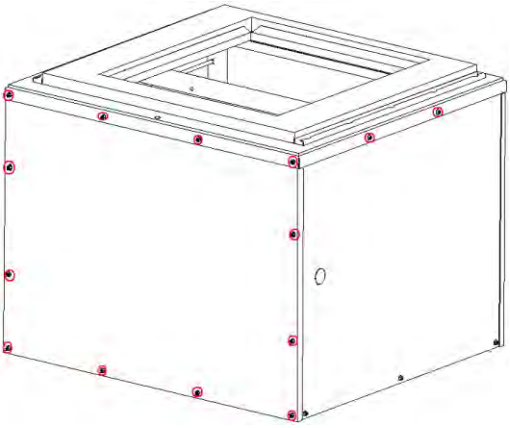
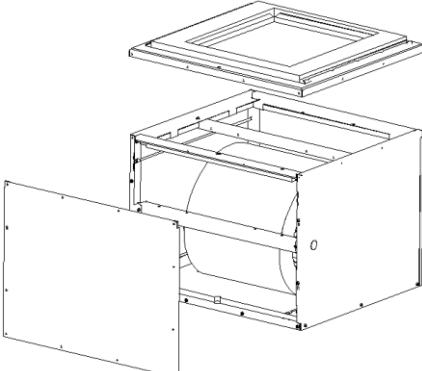
Removal of Blower		
<b>NOTE: Before removing the Blower, make sure power is cut off.</b>		
Step	Picture	Work instruction
<p>1.Remove the screws</p>		<p>● Remove twenty screws from the top cover and front panel.</p>
<p>2. Remove the top cover and front panel.</p>		<p>● Remove the top cover and front panel.</p>

Removal of Blower

**NOTE: Before removing the Blower, make sure power is cut off.**

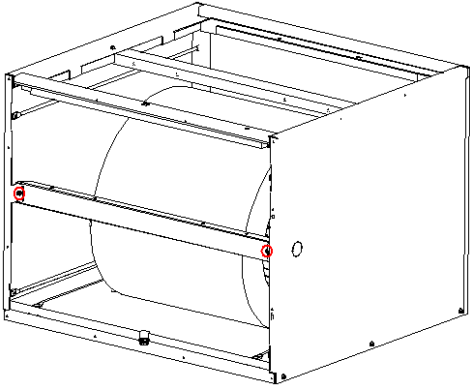
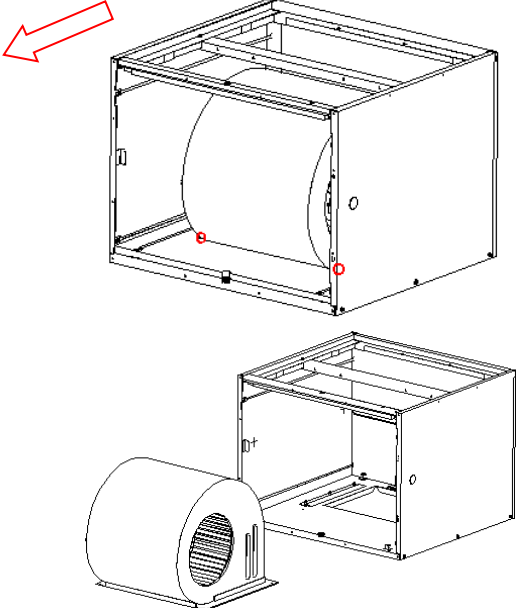
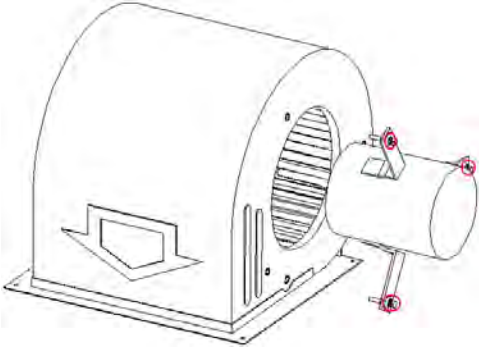
Step	Picture	Work instruction
<p>3. Remove the screws and fixed bracket.</p>		<ul style="list-style-type: none"> <li>● Remove the fixing bracket screws (two in total);</li> <li>● Remove the fixed bracket.</li> </ul>
<p>4. Remove the blower.</p>		<ul style="list-style-type: none"> <li>● Remove the two screws that secure the fan</li> <li>● Drag the blower out in that direction</li> </ul>
<p>5. Replace the motor</p>		<ul style="list-style-type: none"> <li>● Remove the three bolt assemblies that secure the motor and replace the motor</li> </ul>

## 5.6 Explosive View and Lists of Parts

### 5.6.1 Compressor Module Explosive View and Lists of Parts

Model: GCSHPM060IN

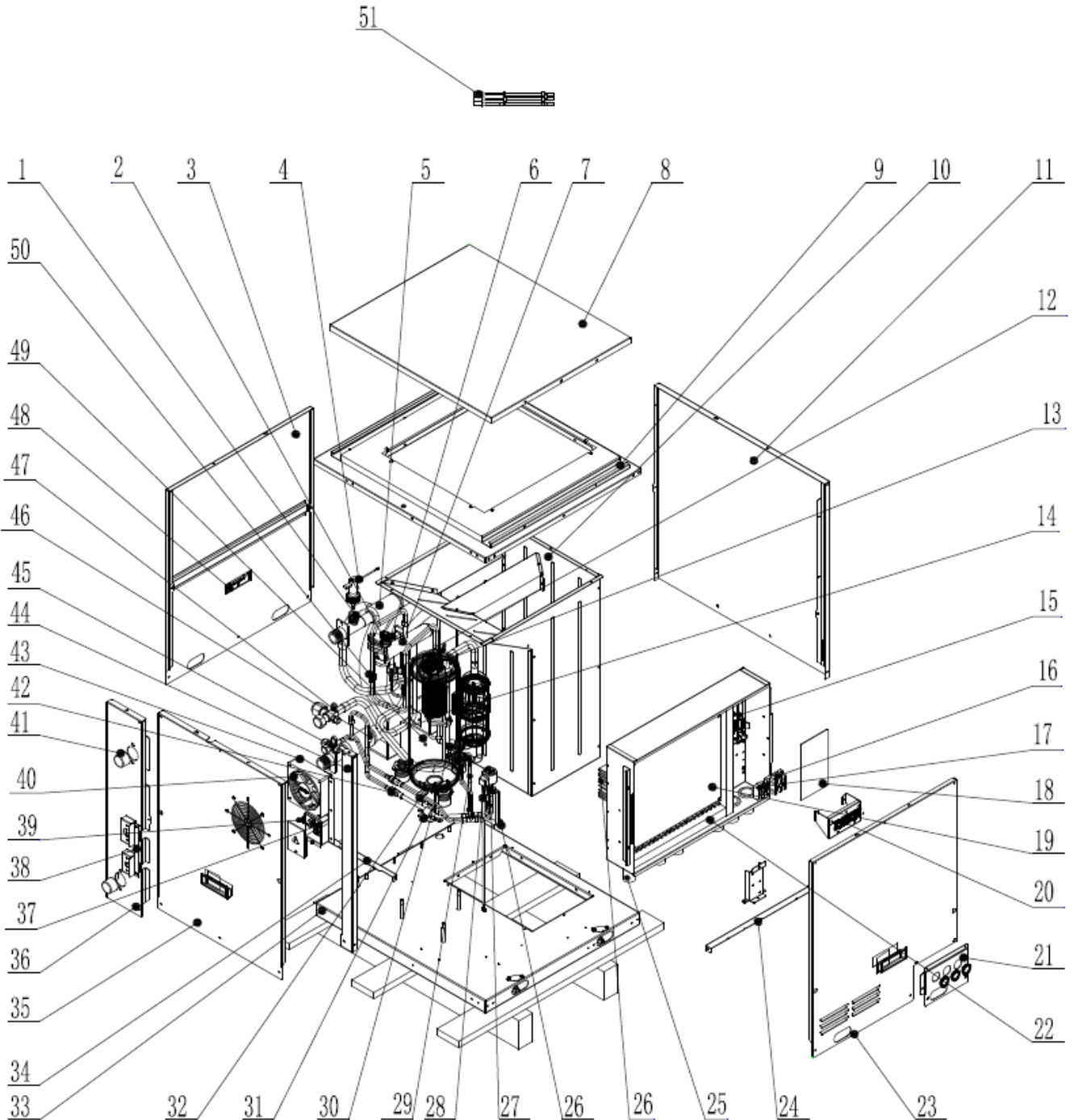

No.	Material name	Part Number
1	O-Ring	760010000026
2	High Pressure Sensor	43004400001503
3	Front Panel Sub-Assy	209004060461
4	Water Flow Switch	430019000006
5	Double Pipe Heat Exchanger	010011060075

No.	Material name	Part Number
6	4 Way Valve Coil	07201006000603
7	4-Way Valve	43000338
8	Lid	012035062355P
9	Top Cover Sub-Assy	017069060114P
10	Air Duct Sub-assy	017107060214
11	Front Panel	209004060460
12	High Pressure Switch	46020006
13	Low Pressure Switch(Ground Water)	460200044
14	Low Pressure Switch(Ground Loop)	4602001596
15	Electrical Retaining Plate	20022700000101
16	Terminal Board	42200006001201
17	Terminal Board	42000100000102
18	Filter Board	300020060118
19	Main Board	300027063069
20	Terminal Board	422000000010
21	Connection Board	012077062176P
22	Electric Raceway	4201030203
23	Front Panel Sub-Assy	209004060463
24	Supporter	012060084641P
25	Rubber Band	7661280504
26	Radiator	430034060222
27	Electric Expand Valve Fitting	4304413266
28	Electronic Expansion Valve	072009060008
29	One Way Valve	071001060011
30	Sensor Insert	42020063
31	Supporter	012060086009P
32	Tube Clip	021400053P
33	Base Frame Assy	000043060667
34	Supporter	012060084642P
35	Front Panel Sub-Assy	209004060455
36	Front Panel Sub-Assy	209004060448
37	Terminal Board	42010185
38	Supporter	012060086133P
39	Cable-Cross Loop	765100263
40	Fan(radiation)	49010501
41	Rubber cover	22240007
42	Filter	035021060019
43	Electric Box Assy	100002080271
44	Front Panel	012073063661P
45	Cut-off valve 3/8(N)	071302391
46	Temp Sensor Sleeving	05212423
47	Cut off Valve	070001000009
48	Handle	2690410001601
49	Compressor and Fittings	009001060898
50	Temperature Sensor clamp	02145007

No.	Material name	Part Number
51	Sensor Sub-assy	390002060442

Model: GCSHPM048IN

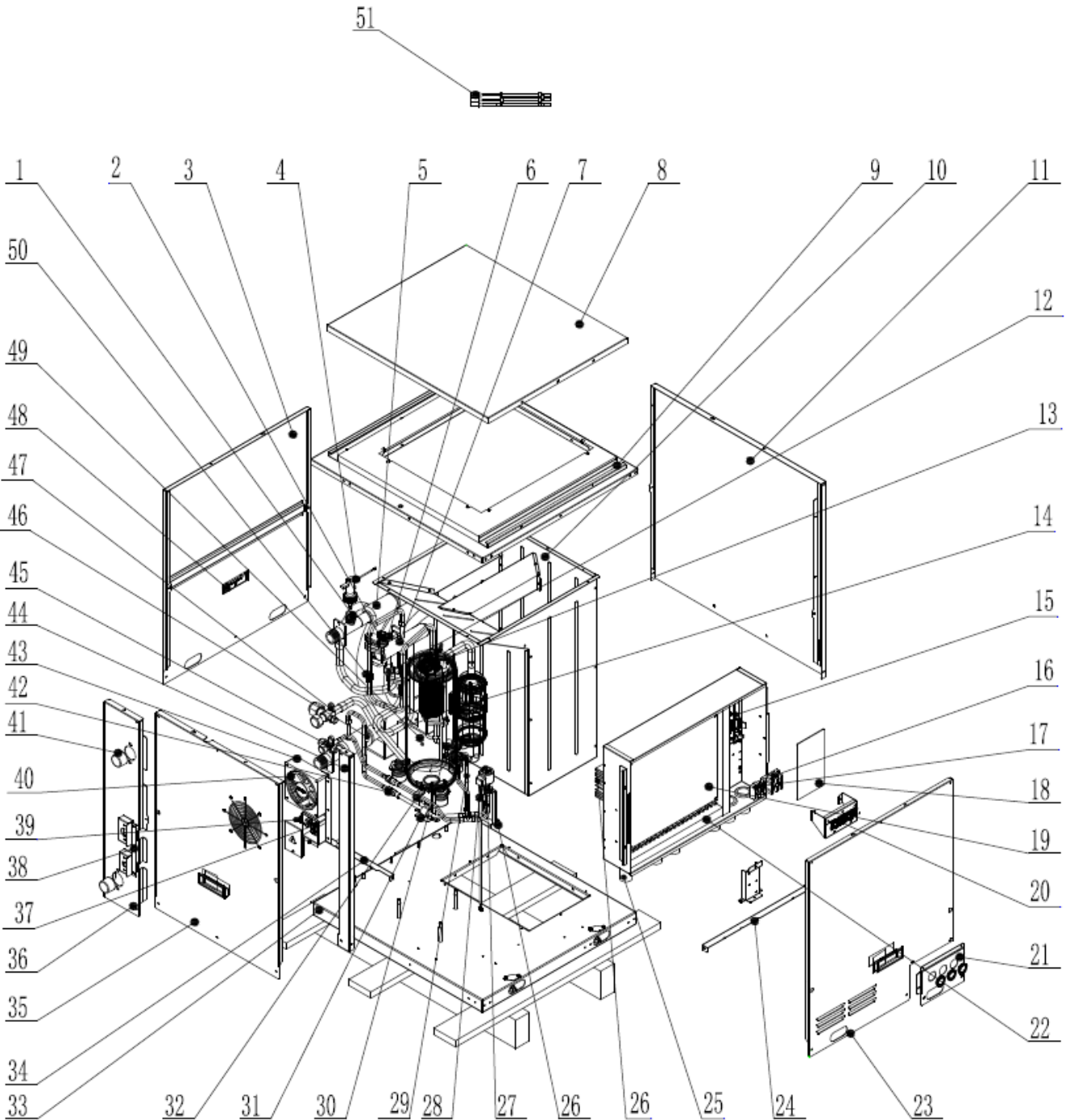

No.	Material name	Part Number
1	O-Ring	760010000026
2	High Pressure Sensor	43004400001503
3	Front Panel Sub-Assy	209004060461
4	Water Flow Switch	430019000006
5	Double Pipe Heat Exchanger	010011060075
6	4 Way Valve Coil	07201006000603
7	4-Way Valve	43000338

No.	Material name	Part Number
8	Lid	012035062355P
9	Top Cover Sub-Assy	017069060114P
10	Air Duct Sub-assy	017107060214
11	Front Panel	209004060460
12	High Pressure Switch	46020006
13	Low Pressure Switch(Ground Water)	460200044
14	Low Pressure Switch(Ground Loop)	4602001596
15	Electrical Retaining Plate	20022700000101
16	Terminal Board	42200006001201
17	Terminal Board	42000100000102
18	Filter Board	300020060118
19	Main Board	300027063706
20	Terminal Board	4220000000010
21	Connection Board	012077062176P
22	Electric Raceway	4201030203
23	Front Panel Sub-Assy	209004060463
24	Supporter	012060084641P
25	Rubber Band	7661280504
26	Radiator	430034060222
27	Electric Expand Valve Fitting	4304413266
28	Electronic Expansion Valve	072009060008
29	One Way Valve	071001060011
30	Sensor Insert	42020063
31	Supporter	012060086009P
32	Tube Clip	021400053P
33	Base Frame Assy	000043060667
34	Supporter	012060084642P
35	Front Panel Sub-Assy	209004060455
36	Front Panel Sub-Assy	209004060448
37	Terminal Board	42010185
38	Supporter	012060086133P
39	Cable-Cross Loop	765100263
40	Fan(radiation)	49010501
41	Rubber cover	22240007
42	Filter	035021060019
43	Electric Box Assy	100002080271
44	Front Panel	012073063661P
45	Cut-off valve 3/8(N)	071302391
46	Temp Sensor Sleeving	05212423
47	Cut off Valve	070001000009
48	Handle	2690410001601
49	Compressor and Fittings	009001060898
50	Temperature Sensor clamp	02145007
51	Sensor Sub-assy	390002060442



## 5.6.2 A-Coil Module Explosive View and Lists of Parts

Model: GCSCAM060GN

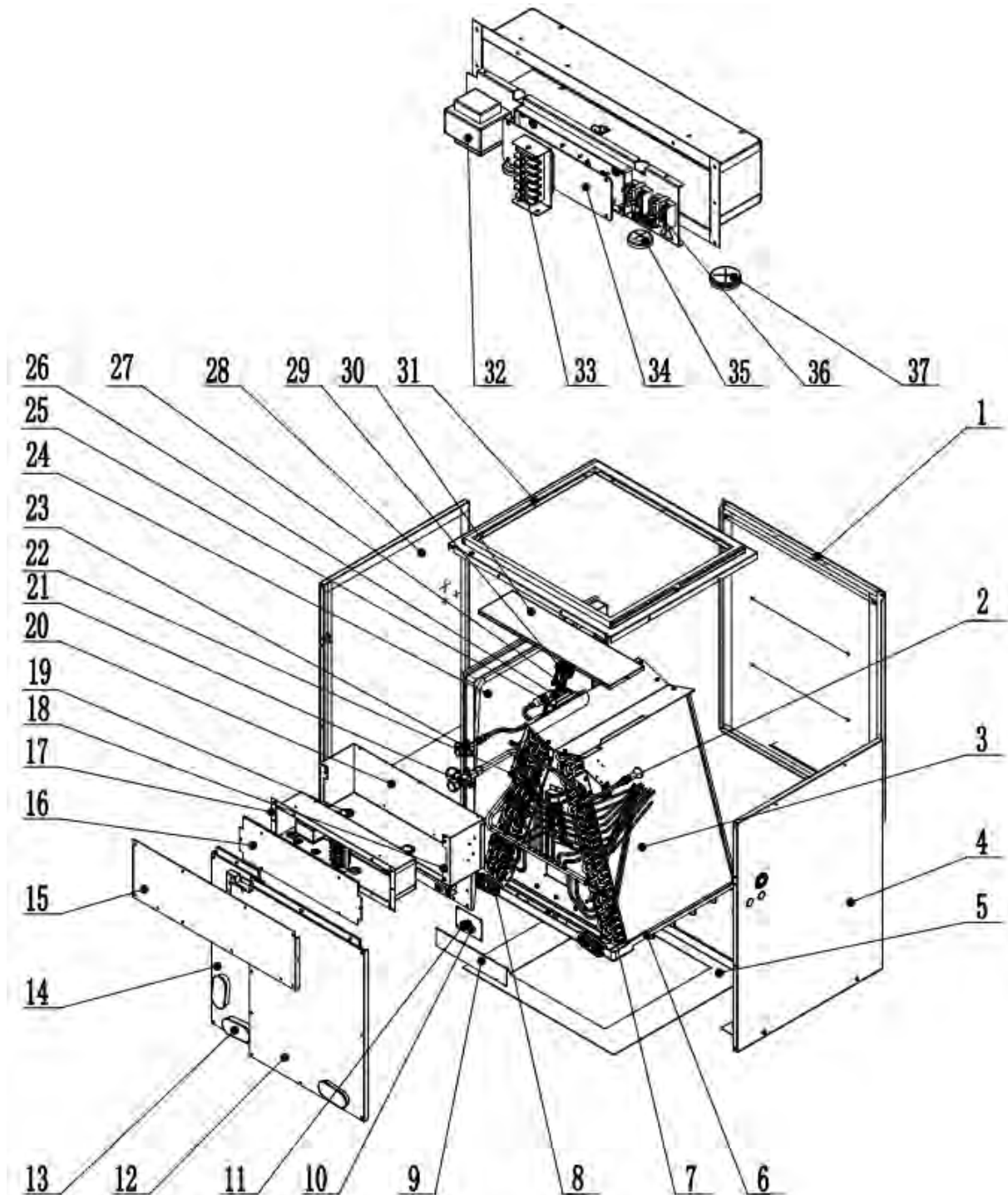

No.	Material name	Part Number
1	Rear Side Plate Sub-Assy	017051060175
2	Filter	035021060019
3	Evaporator Assy	011001062780
4	Right Side Plate Sub-Assy	000130060170
5	Air Outlet Frame Sub-assy	000117060028
6	Water Tray	2690220601
7	Sensor Insert	42020063

No.	Material name	Part Number
8	Choke Plug	76718209
9	Retaining Plate (Water Level Switch)	012066062210
10	Support Assy	000157060222
11	Cable-Cross Loop	765100263
12	Cover Plate Sub-Assy	011657060546
13	Plastic Cover	26902209
14	Cover Plate Sub-Assy	011657060547
15	Cover Plate Sub-Assy	011657060556
16	Electric Box Cover	012020061074P
17	Electric Box Assy	100002078180
18	Rubber Band	7661280504
19	Rubber Band	7661280503
20	Support Assy	000157060224
21	Cut off Valve 3/4N	070001000009
22	Temp Sensor Sleeving	05212423
23	Cut off Valve 3/8N	071302391
24	Water Tray	2690220501
25	One Way Valve	071001060012
26	Tube Clip	021400053P
27	Electronic Expansion Valve	072009060008
28	Left Side Plate Sub-Assy	017037060351
29	Electric Expand Valve Fitting	07200206002329
30	Support Assy	000157060223
31	Top Cover Sub-Assy	000051060221
32	Transformer	43110286
33	Terminal Board	422000060007
34	Main Board	300002063486
35	Cable Cross Loop	76510021
36	Terminal Board	42000100000102
37	Cable Cross Loop	76510021



Model: GCSCAM048GN

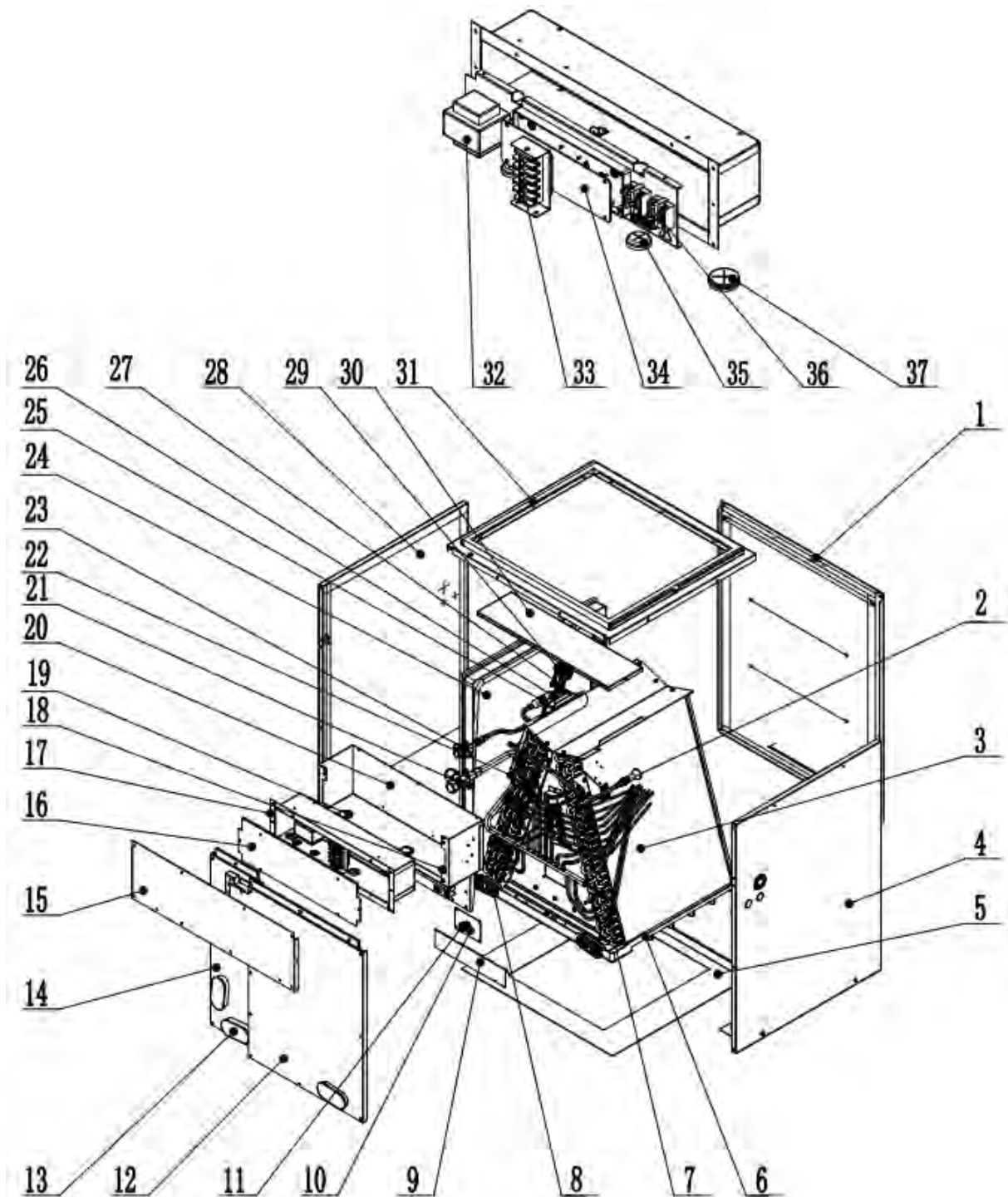

No.	Material name	Part Number
1	Rear Side Plate Sub-Assy	017051060175
2	Filter	035021060019
3	Evaporator Assy	011001062780
4	Right Side Plate Sub-Assy	000130060170
5	Air Outlet Frame Sub-assy	000117060028
6	Water Tray	2690220601
7	Sensor Insert	42020063
8	Choke Plug	76718209

No.	Material name	Part Number
9	Retaining Plate (Water Level Switch)	012066062210
10	Support Assy	000157060222
11	Cable-Cross Loop	765100263
12	Cover Plate Sub-Assy	011657060546
13	Plastic Cover	26902209
14	Cover Plate Sub-Assy	011657060547
15	Cover Plate Sub-Assy	011657060556
16	Electric Box Cover	012020061074P
17	Electric Box Assy	100002081473
18	Rubber Band	7661280504
19	Rubber Band	7661280503
20	Support Assy	000157060224
21	Cut off Valve 3/4N	070001000009
22	Temp Sensor Sleeving	05212423
23	Cut off Valve 3/8N	071302391
24	Water Tray	2690220501
25	One Way Valve	071001060012
26	Tube Clip	021400053P
27	Electronic Expansion Valve	072009060008
28	Left Side Plate Sub-Assy	017037060351
29	Electric Expand Valve Fitting	07200206002329
30	Support Assy	000157060223
31	Top Cover Sub-Assy	000051060221
32	Transformer	43110286
33	Terminal Board	422000060007
34	Main Board	300002063947
35	Cable Cross Loop	76510021
36	Terminal Board	42000100000102
37	Cable Cross Loop	76510021

### 5.6.3 Blower Module Explosive View and Lists of Parts

Model: GCSBLM013 / GCSBLM014

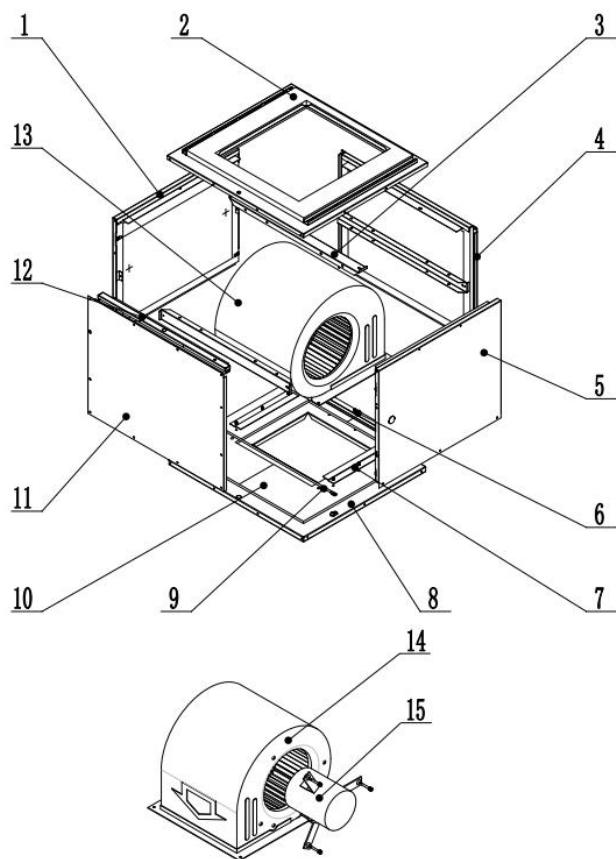

No.	Material name	Part Number
1	Front Panel Sub-Assy	209004060428
2	Top Cover Sub-Assy	000051060226
3	Supporter	012060084723P
4	Front Panel Sub-Assy	209004060427
5	Front Panel Sub-Assy	209004060429
6	Retaining Plate Sub-Assy	017032060759
7	Fan fixing plate assembly 1	01842232
8	Cover Plate Sub-Assy	011657060549P
9	Wire	012222000025
10	Sponge	110000076297
11	Front Panel Sub-Assy	209004060430
12	Support Assy	000157060233
13	Centrifugal fan assy	000052060818
14	Centrifugal Fan Housing	1570220301
15	Brushless DC Motor	15010400001304

## 5 COMMON PARAMETER LISTS

### 5.1 Temperature/Pressure List of Refrigerant

R410A							
Temperature	Pressure		Temperature	Pressure		Temperature	Pressure
°C	kPa		°C	kPa		°C	kPa
-30	275		0	803		30	1880
-29	286		1	823		31	1910
-28	298		2	851		32	1960
-27	311		3	879		33	2030
-26	324		4	903		34	2080
-25	334		5	937		35	2130
-24	348		6	962		36	2180
-23	363		7	994		37	2240
-22	375		8	1020		38	2290
-21	391		9	1050		39	2350
-20	404		10	1090		40	2410
-19	424		11	1110		41	2460
-18	435		12	1150		42	2510
-17	453		13	1180		43	2580
-16	468		14	1220		44	2650
-15	483		15	1250		45	2710
-14	504		16	1280		46	2770
-13	520		17	1320		47	2840
-12	538		18	1350		48	2910
-11	556		19	1400		49	2980
-10	579		20	1440		50	3050
-9	598		21	1470		51	3100
-8	618		22	1520		52	3180
-7	639		23	1560		53	3250
-6	660		24	1600		54	3320
-5	682		25	1640		55	3400
-4	705		26	1680		56	3480
-3	728		27	1730		57	3540
-2	752		28	1780		58	3630
-1	777		29	1820		59	3720

## 5.2 Resistance / Temperature Lists of Temperature Sensors

### 5.2.1 Voltage list of 15 k $\Omega$ temperature sensors (including return air temperature sensors)

Temp. (°C)	Resistance (k $\Omega$ )	Voltage (15K/5V)	Voltage (15K/3.3V)	Temp. (°C)	Resistance (k $\Omega$ )	Voltage (15K/5V)	Voltage (15K/3.3V)
-20	144	0.472	0.311	25	15	2.5	1.65
-19	138.1	0.49	0.323	26	14.36	2.554	1.686
-18	128.6	0.522	0.345	27	13.74	2.61	1.722
-17	121.6	0.549	0.362	28	13.16	2.663	1.758
-16	115	0.577	0.381	29	12.6	2.717	1.793
-15	108.7	0.606	0.4	30	12.07	2.771	1.829
-14	102.9	0.636	0.42	31	11.57	2.823	1.863
-13	97.4	0.667	0.44	32	11.09	2.875	1.897
-12	92.22	0.699	0.462	33	10.63	2.926	1.931
-11	87.35	0.733	0.484	34	10.2	2.976	1.964
-10	82.75	0.767	0.506	35	9.779	3.027	1.998
-9	78.43	0.803	0.53	36	9.382	3.076	2.03
-8	74.35	0.839	0.554	37	9.003	3.125	2.062
-7	70.5	0.877	0.579	38	8.642	3.172	2.094
-6	66.88	0.916	0.605	39	8.297	3.219	2.125
-5	63.46	0.956	0.631	41	7.653	3.311	2.185
-4	60.23	0.997	0.658	42	7.352	3.355	2.215
-3	57.18	1.039	0.686	43	7.065	3.399	2.243
-2	54.31	1.082	0.714	44	6.791	3.442	2.272
-1	51.59	1.126	0.743	45	6.529	3.484	2.299
0	49.02	1.172	0.773	46	6.278	3.525	2.326
1	46.8	1.214	0.801	47	6.038	3.565	2.353
2	44.31	1.265	0.835	48	5.809	3.604	2.379
3	42.14	1.313	0.866	49	5.589	3.643	2.404
4	40.09	1.361	0.899	50	5.379	3.68	2.429
5	38.15	1.411	0.931	51	5.179	3.717	2.453
6	36.32	1.461	0.965	52	4.986	3.753	2.477
7	34.58	1.513	0.998	53	4.802	3.787	2.5
8	32.94	1.564	1.033	54	4.625	3.822	2.522
9	31.38	1.617	1.067	55	4.456	3.855	2.544
10	29.9	1.67	1.102	56	4.294	3.887	2.566
11	28.51	1.724	1.138	57	4.139	3.919	2.586
12	27.18	1.778	1.174	58	3.99	3.949	2.607
13	25.92	1.833	1.21	59	3.848	3.979	2.626
14	24.73	1.888	1.246	60	3.711	4.008	2.646
15	23.6	1.943	1.282	61	3.579	4.037	2.664
16	22.53	1.998	1.319	62	3.454	4.064	2.682

17	21.51	2.054	1.356	63	3.333	4.091	2.7
18	20.54	2.11	1.393	64	3.217	4.117	2.717
19	19.63	2.166	1.429	65	3.105	4.143	2.734
20	18.75	2.222	1.467	66	2.998	4.167	2.75
21	17.93	2.278	1.503	67	2.898	4.19	2.766
22	17.14	2.334	1.54	68	2.797	4.214	2.781
23	16.39	2.389	1.577	69	2.702	4.237	2.796
24	15.68	2.445	1.613	70	2.611	4.259	2.811

## 5.2.2 Voltage list of 20 kΩ pipeline temperature sensors (including temperature sensors for water inlet, water outlet, liquid/gas pipe, suction, in-tube)

Temp. (°C)	Resistance (kΩ)	Voltage (15K/5V)	Voltage (15K/3.3V)	Temp. (°C)	Resistance (kΩ)	Voltage (15K/5V)	Voltage (15K/3.3V)
-20	196.9	0.461	0.304	28	17.55	2.663	1.758
-19	181.4	0.497	0.328	29	16.8	2.717	1.793
-18	171.4	0.522	0.345	30	16.1	2.77	1.828
-17	162.1	0.549	0.362	31	15.43	2.822	1.863
-16	153.3	0.577	0.381	32	14.79	2.874	1.897
-15	145	0.606	0.4	33	14.18	2.926	1.931
-14	137.2	0.636	0.42	34	13.59	2.977	1.965
-13	129.9	0.667	0.44	35	13.04	3.027	1.998
-12	123	0.699	0.462	36	12.51	3.076	2.03
-11	116.5	0.733	0.484	37	12	3.125	2.063
-10	110.3	0.767	0.507	38	11.52	3.173	2.094
-9	104.6	0.803	0.53	39	11.06	3.22	2.125
-8	99.13	0.839	0.554	40	10.62	3.266	2.155
-7	94	0.877	0.579	41	10.2	3.311	2.185
-6	89.17	0.916	0.605	42	9.803	3.355	2.215
-5	84.61	0.956	0.631	43	9.42	3.399	2.243
-4	80.31	0.997	0.658	44	9.054	3.442	2.272
-3	76.24	1.039	0.686	45	8.705	3.484	2.299
-2	72.41	1.082	0.714	46	8.37	3.525	2.326
-1	68.79	1.126	0.743	47	8.051	3.565	2.353
0	65.37	1.171	0.773	48	7.745	3.604	2.379
1	62.13	1.218	0.804	49	7.453	3.643	2.404
2	59.08	1.265	0.835	50	7.173	3.68	2.429
3	56.19	1.313	0.866	51	6.905	3.717	2.453
4	53.46	1.361	0.898	52	6.648	3.753	2.477
5	50.87	1.411	0.931	53	6.403	3.787	2.5
6	48.42	1.462	0.965	54	6.167	3.822	2.522
7	46.11	1.513	0.998	55	5.942	3.855	2.544
8	43.92	1.564	1.033	56	5.726	3.887	2.565
9	41.84	1.617	1.067	57	5.519	3.919	2.586
10	39.87	1.67	1.102	58	5.32	3.949	2.607
11	38.01	1.724	1.138	59	5.13	3.979	2.626
12	36.24	1.778	1.174	60	4.948	4.008	2.646
13	34.57	1.833	1.209	61	4.773	4.037	2.664
14	32.98	1.888	1.246	62	4.605	4.064	2.682
15	31.47	1.943	1.282	63	4.443	4.091	2.7
16	30.04	1.998	1.319	64	4.289	4.117	2.717
17	28.68	2.054	1.356	65	4.14	4.143	2.734

18	27.39	2.11	1.393	66	3.998	4.167	2.75
19	26.17	2.166	1.429	67	3.861	4.191	2.766
20	25.01	2.222	1.466	68	3.729	4.214	2.781
21	23.9	2.278	1.503	69	3.603	4.237	2.796
22	22.85	2.334	1.54	70	3.481	4.259	2.811
23	21.85	2.389	1.577	71	3.364	4.28	2.825
24	20.9	2.445	1.614	72	3.252	4.301	2.838
25	20	2.5	1.65	73	3.144	4.321	2.852
26	19.14	2.555	1.686	74	3.04	4.34	2.865
27	18.32	2.61	1.722	75	2.94	4.359	2.877



### 5.2.3 Voltage list of 50 kΩ discharge temperature sensors (including discharge air temperature sensor)

Temp. (°C)	Resistance (kΩ)	Voltage (15K/5V)	Voltage (15K/3.3V)	Temp. (°C)	Resistance (kΩ)	Voltage (15K/5V)	Voltage (15K/3.3V)
-30	911.56	0.054	0.036	8	107.96	0.424	0.28
-29	853.66	0.058	0.038	9	102.85	0.443	0.292
-28	799.98	0.062	0.041	10	98.006	0.463	0.306
-27	750.18	0.066	0.043	11	93.42	0.483	0.319
-26	703.92	0.07	0.046	12	89.075	0.505	0.333
-25	660.93	0.075	0.049	13	84.956	0.527	0.348
-24	620.94	0.079	0.052	14	81.052	0.549	0.362
-23	583.72	0.084	0.056	15	77.349	0.572	0.378
-22	549.04	0.089	0.059	16	73.896	0.596	0.393
-21	516.71	0.095	0.063	17	70.503	0.621	0.41
-20	486.55	0.101	0.066	18	67.338	0.647	0.427
-19	458.4	0.107	0.07	19	64.333	0.673	0.444
-18	432.1	0.113	0.075	20	61.478	0.7	0.462
-17	407.51	0.12	0.079	21	58.766	0.727	0.48
-16	384.51	0.127	0.084	22	56.189	0.755	0.499
-15	362.99	0.134	0.088	23	53.738	0.784	0.518
-14	342.83	0.142	0.094	24	51.408	0.814	0.537
-13	323.94	0.15	0.099	25	49.191	0.845	0.558
-12	306.23	0.158	0.104	26	47.082	0.876	0.578
-11	289.61	0.167	0.11	27	45.074	0.908	0.599
-10	274.02	0.176	0.116	28	43.163	0.941	0.621
-9	259.37	0.186	0.123	29	41.313	0.974	0.643
-8	245.61	0.196	0.129	30	39.61	1.008	0.665
-7	232.67	0.206	0.136	31	37.958	1.043	0.688
-6	220.5	0.217	0.143	32	36.384	1.078	0.711
-5	209.05	0.228	0.151	33	34.883	1.114	0.735
-4	198.27	0.24	0.158	34	33.453	1.151	0.759
-3	188.12	0.252	0.167	35	32.088	1.188	0.784
-2	178.65	0.265	0.175	36	30.787	1.226	0.809
-1	169.68	0.278	0.184	37	29.544	1.264	0.835
0	161.02	0.292	0.193	38	28.359	1.303	0.86
1	153	0.307	0.202	39	27.227	1.343	0.886
2	145.42	0.322	0.212	40	26.147	1.383	0.913
3	138.26	0.337	0.223	41	25.114	1.424	0.94
4	131.5	0.353	0.233	42	24.128	1.465	0.967
5	126.17	0.367	0.242	43	23.186	1.507	0.994
6	119.08	0.387	0.256	44	22.286	1.549	1.022
7	113.37	0.405	0.267	45	21.425	1.591	1.05

Temp. (°C)	Resistance (kΩ)	Voltage (15K/5V)	Voltage (15K/3.3V)	Temp. (°C)	Resistance (kΩ)	Voltage (15K/5V)	Voltage (15K/3.3V)
45	21.425	1.591	1.05	88	4.7541	3.389	2.237
46	20.601	1.634	1.078	89	4.6091	3.423	2.259
47	19.814	1.677	1.107	90	4.4693	3.456	2.281
48	19.061	1.721	1.136	91	4.3345	3.488	2.302
49	18.34	1.764	1.164	92	4.2044	3.52	2.323
50	17.651	1.808	1.193	93	4.0789	3.551	2.344
51	16.99	1.853	1.223	94	3.9579	3.582	2.364
52	16.358	1.897	1.252	95	3.841	3.612	2.384
53	15.753	1.942	1.281	96	3.7283	3.642	2.404
54	15.173	1.986	1.311	97	3.6194	3.671	2.423
55	14.618	2.031	1.34	98	3.5143	3.7	2.442
56	14.085	2.076	1.37	99	3.4128	3.728	2.46
57	13.575	2.121	1.4	100	3.3147	3.755	2.478
58	13.086	2.166	1.429	101	3.22	3.782	2.496
59	12.617	2.211	1.459	102	3.1285	3.809	2.514
60	12.368	2.235	1.475	103	3.0401	3.834	2.531
61	11.736	2.3	1.518	104	2.9547	3.86	2.547
62	11.322	2.345	1.548	105	2.8721	3.884	2.564
63	10.925	2.389	1.577	106	2.7922	3.909	2.58
64	10.544	2.434	1.606	107	2.715	3.932	2.595
65	10.178	2.478	1.635	108	2.6404	3.956	2.611
66	9.8269	2.522	1.664	109	2.5682	3.978	2.626
67	9.4896	2.565	1.693	110	2.4983	4.001	2.64
68	9.1655	2.609	1.722	111	2.4308	4.022	2.655
69	8.9542	2.638	1.741	112	2.3654	4.044	2.669
70	8.5551	2.695	1.778	113	2.3021	4.064	2.682
71	8.2676	2.737	1.806	114	2.2409	4.085	2.696
72	7.9913	2.779	1.834	115	2.1816	4.105	2.709
73	7.7257	2.821	1.862	116	2.1242	4.124	2.722
74	7.4702	2.862	1.889	117	2.0686	4.143	2.734
75	7.2245	2.903	1.916	118	2.0148	4.162	2.747
76	6.9882	2.943	1.943	119	1.9626	4.18	2.759
77	6.7608	2.983	1.969	120	1.9123	4.197	2.77
78	6.542	3.023	1.995	121	1.8652	4.214	2.781
79	6.3315	3.062	2.021	122	1.8158	4.232	2.793
80	6.1288	3.1	2.046	123	1.7698	4.248	2.804
81	5.9336	3.138	2.071	124	1.7253	4.264	2.814
82	5.7457	3.175	2.096	125	1.6821	4.28	2.825
83	5.5647	3.212	2.12	126	1.6402	4.295	2.835
84	5.3903	3.249	2.144	127	1.5996	4.31	2.845
85	5.2223	3.285	2.168	128	1.5602	4.325	2.855
86	5.0605	3.32	2.191	129	1.522	4.34	2.864
87	4.9044	3.355	2.214	130	1.485	4.354	2.873

## 6 Operation Tools

The following tools will be used: 1) Liquid-level gauge; 2) Screwdriver; 3) Electric driven rotary hammer; 4) Drill; 5) Pipe expander; 6) Torque wrench; 7) Open-end wrench; 8) Pipe cutter; 9) Leak detector; 10) Vacuum pump; 11) Pressure gauge; 12) Universal meter; 13) Hexagon wrench; 14) Tapeline.